

*Most - Often - Needed*

1957

VOLUME 17

**RADIO**  
**DIAGRAMS**  
*and Servicing Information*



Compiled by

**M. N. BEITMAN**

**SUPREME PUBLICATIONS**

## RADIO DIAGRAM MANUALS

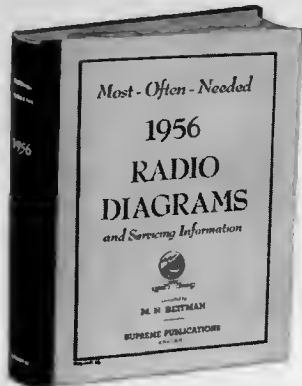

New 1956 **VOLUME 16**  
Price **\$2.50**

Repair quickly all new 1956 sets as well as older radios. This big volume contains clearly printed, large schematics, needed alignment data, replacement parts lists, voltage values, and information on stage gain, location of trimmers, and dial stringing, for all important new 1956 sets. Includes material on portables, clock radios, record changers, FM, and auto sets. A worthy companion to fourteen previous volumes used by over 143,000 shrewd radio servicemen. Large size: 8½ x 11 inches. Manual style binding. Postpaid, only **\$250**

## RADIO DIAGRAMS FOR PREVIOUS YEARS

Speed up and simplify all radio repairs. Service radios faster, better, easier, save money and time, use these **SUPREME Most-Ofen-Needed** diagram manuals to get ahead. At the low cost (only \$2 for most volumes) you are assured of having for every job needed diagrams and other essential repair data on 4 out of 5 sets you will ever service. Clearly printed circuits, parts lists, alignment data, and helpful service hints are the facts you need. Average volume has 192 pages, large size 8½ x 11 inches. Manual style binding.

- |   |   |   |   |   |
|---|---|---|---|---|
| <input type="checkbox"/> 1955<br>Volume 15<br><b>\$2.00</b> | <input type="checkbox"/> 1954<br>Volume 14<br><b>\$2.50</b> | <input type="checkbox"/> 1953<br>Volume 13<br><b>\$2.50</b> | <input type="checkbox"/> 1952<br>Volume 12<br><b>\$2.50</b> | <input type="checkbox"/> 1951<br>Volume 11<br><b>\$2.50</b>     |
| <input type="checkbox"/> 1950<br>Volume 10<br><b>\$2.50</b> | <input type="checkbox"/> 1949<br>Volume 9<br><b>\$2.50</b>  | <input type="checkbox"/> 1948<br>Volume 8<br><b>\$2.00</b>  | <input type="checkbox"/> 1947<br>Volume 7<br><b>\$2.00</b>  | <input type="checkbox"/> 1946<br>Volume 6<br><b>\$2.00</b>      |
| <input type="checkbox"/> 1942<br>Volume 5<br><b>\$2.00</b>  | <input type="checkbox"/> 1941<br>Volume 4<br><b>\$2.00</b>  | <input type="checkbox"/> 1940<br>Volume 3<br><b>\$2.00</b>  | <input type="checkbox"/> 1939<br>Volume 2<br><b>\$2.00</b>  | <input type="checkbox"/> 1926-1938<br>Volume 1<br><b>\$2.50</b> |

INDEX for all Radio and TV Manuals ..... **25¢**

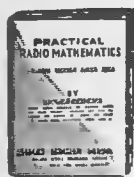

## RADIO MATHEMATICS

Explains arithmetic and simple algebra in connection with units, color code, meter scales, Ohm's law, alternating currents, ohmmeter testing, wattage rating, series and parallel connections, capacity, inductance, mixed circuits, vacuum tubes, curves, the decibel, etc., and has numerous examples. Only **25¢**



## How to Modernize Radios

Cash in by improving and modernizing all out of date radio sets and cabinets. Practical job-sheets with schematics and photographs make this work easy. Size 8½ x 11 inches. Your price only **\$1**

ARVIN DIAGRAM Manual (Pre-War Radios) **50c**

## RADIO SERVICING COURSE



Here is your practical radio course of 22 easy-to-follow lessons. Review fundamentals, learn new servicing tricks. Just like a \$200.00 correspondence course. Everything in radio servicing. With self-testing questions. New edition. Price only **\$250**

## SUPREME TELEVISION MANUALS

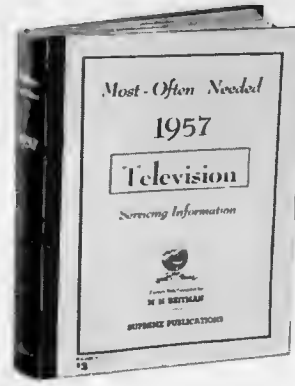

1957 TV Manual, TV-12

This new giant volume of 1957 television factory data will give you everything you need to repair and adjust all present-day TV sets. The **television series** manuals are amazing bargains and defy competition. The 1957 volume contains circuit explanations, 192 pages of alignment facts, test patterns, response curves, waveforms, voltage charts, hints, and dozens of mammoth double-page work-bench diagrams. Large size 8½ x 11 inches. Sturdy covers. Book binding opens flat. Amazing value. Price postpaid, only **\$3**

## EARLIER TV MANUALS FOR 1956 TO 1948

*Supreme TV* manuals cover all needed service material on every popular TV set of every important manufacturer. Here is helpful, practical, factory-prepared data that will really make TV servicing and adjustment easy for you. *Supreme* giant TV manuals have complete circuits, alignment facts, test patterns, response curves, service hints, recommended changes, voltage charts, waveforms, and many double-page diagram blueprints. Here is your TV service material to help you do more expert work quicker; and priced at only \$3. The **UHF Converters** manual at only \$1.50 has everything you need on UHF. **Radio** manuals described at left.

- |   |  |  |  |
|---|--|--|--|
| <input type="checkbox"/> 1956 TV<br>Volume TV-11<br><b>\$3.00</b> | <input type="checkbox"/> 1955 TV<br>Additional, TV-10<br><b>\$3.00</b> | <input type="checkbox"/> 1955 TV<br>Early, Vol. TV-9<br><b>\$3.00</b>  | <input type="checkbox"/> 1954 TV<br>Volume TV-8<br><b>\$3.00</b> |
| <input type="checkbox"/> 1953 TV<br>Volume TV-7<br><b>\$3.00</b>  | <input type="checkbox"/> 1952 TV<br>Volume TV-6<br><b>\$3.00</b>       | <input type="checkbox"/> 1951 TV<br>Volume TV 5<br><b>\$3.00</b>       | <input type="checkbox"/> 1950 TV<br>Volume TV-4<br><b>\$3.00</b> |
| <input type="checkbox"/> 1949 TV<br>Volume TV-3<br><b>\$3.00</b>  | <input type="checkbox"/> 1948 TV<br>Volume TV-2<br><b>\$3.00</b>       | <input type="checkbox"/> UHF Converters<br>Volume UHF-1, <b>\$1.50</b> |  |

## TELEVISION SERVICING COURSE

Let this new course teach you TV servicing. Amazing bargain, complete only \$3, full price for all lessons. Giant in size, mammoth in scope, topics just like a \$200.00 correspondence course. Lessons on picture faults, circuits, adjustments, short-cuts, UHF, alignment hints, antenna problems, trouble-shooting, test equipment, picture analysis. Special, only **\$3**

## Practical Radio & Electronics Course

Here is your complete home study course of 53 lessons designed to train any beginner to be an expert in radio and electronics. Covers every topic of radio, electronics, with lessons on test equipment, FM, TV, radio, etc. Giant 8½ x 11 inches, 3-in-1 volume, includes all lessons, instructor's notes, test questions. New edition. Only **\$395**

ANSWER BOOK to the above course ..... **25¢**

## Simplified Radio Servicing by COMPARISON Method

Revolutionary different **COMPARISON** technique permits you to do expert work on all radio sets. Most repairs can be made without test equipment or with only a volt-ohmmeter. Many simple, point-to-point, cross-reference, circuit suggestions locate the faults instantly. Plan copyrighted. Covers every radio set - new and old models. This new servicing technique presented in handy manual form, size 8½ x 11 inches, 92 pages. Over 1,000 practical service hints. 26 large, trouble-shooting blueprints. Charts for circuit analysis. 114 tests using a 5c resistor. Developed by M. N. Beitman. New edition. Price only **\$150**



# Admiral

## Chassis 3K1

MODEL	COLOR	CHASSIS
HT2236	Mahogany	3K1
HT2237	Blond	3K1

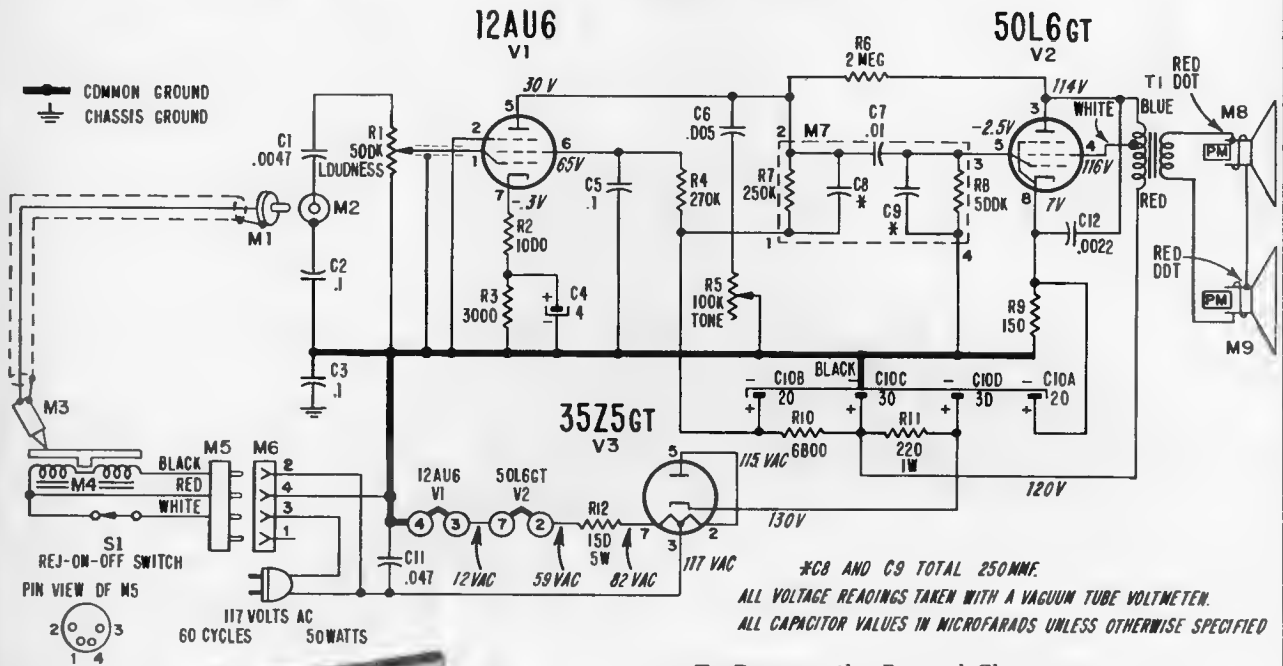

### TO REMOVE THE CHASSIS

After removing the line cord plug from the wall outlet, clamp the TONE ARM to the tone arm rest. Carefully turn the phonograph upside down on a soft, padded surface. Remove the two screws mounting the chassis to the cabinet. Then turn the phonograph upright and remove the screw countersunk in the rear of the cabinet. Remove the speed-nuts holding the speaker to the cabinet. The output transformer leads are soldered to the speakers. Speakers and chassis must be removed as a unit. Disconnect the record changer motor plug (M5) and carefully lift the chassis and speaker assembly from the cabinet.

### To Remove the Record Changer:

The record changer and its mounting board come out as a unit. Fasten the TONE ARM to the tone arm rest. Remove the six mounting board screws. Tilt the right edge of the mounting board until the record changer and mounting board clear the cabinet lid stay-arm mounting bracket. It should not be necessary to remove this bracket. If, however, it is ever necessary to remove this bracket, care must be taken to avoid damaging the cabinet lid hinges. Carefully lift the record changer and mounting board from the cabinet. For convenience, the motor plug and audio input plug may be disconnected from the chassis, and the record changer set aside.

### Service Note:

The "REJ-ON-OFF" switch (S1) on the record changer operates both amplifier and record changer motor. To operate the amplifier and measure voltages with the record changer disconnected, a short, temporary jumper wire must be connected between common ground and the single lead from one side of the AC line on socket "M6". See schematic.

Amplifier voltage readings may also be taken by connecting the record changer motor plug (M5) to the socket (M6) on the tone arm rest and move the REJ-ON-OFF switch to the "ON" position.

Set LOUDNESS control for minimum and the TONE control to the center of its range. Do not play record while taking readings.



# Admiral

CHASSIS 4E2 and 4H2  
 MODELS 4E21 • 4F22 • 4F24 • 4F26 • 4F28  
 4H22 • 4H24 • 4H26 • 4H28

(Continued from page 4, adjacent at left)

## ALIGNMENT PROCEDURE

- Battery power is preferable for alignment; use FRESH batteries. If this set is to be aligned while operating on an AC power line, an isolation transformer should be used. If an isolation transformer is not available, connect a .1 mfd. capacitor in series with the signal generator low side to B minus (pin 7 of 1U5 tube).
- The case top cover must be removed to align IF (step 1).
- Set Volume control to maximum.
- Connect output meter across speaker voice coil.
- Use lowest setting of signal generator capable of producing adequate indication on lowest scale of output meter.
- Use a non-metallic alignment tool for IF transformers.
- Repeat adjustments to insure good results.

Step	Dummy Antenna in Series with Signal Generator	Connection of Signal Generator (High Side)	Signal Generator Frequency	Receiver Gang Setting	Adjustment Description	Adjustment Designation	Type of Adjustment
1	.1 mfd. capacitor	Stator of antenna tuning capacitor	455 KC	Gang fully open	2nd IF 1st IF	A, B* C, D*	Maximum output
Install the case top section removed during IF Alignment							
2	Loop of several turns of wire, or place generator lead close to receiver for adequate signal pickup.	No actual connection (signal by radiation)	1620 KC	Gang fully open	Oscillator (on gang)	E	Maximum output
3	Loop of several turns of wire, or place generator lead close to receiver for adequate signal pickup.	No actual connection (signal by radiation)	1400 KC	Tune in generator signal	Antenna (on gang)	F	Maximum output

\*Adjustments B and D are made from underside of chassis. See figure 1. To avoid splitting the slotted head of powdered iron tuning slug in IF transformers, use an alignment tool with a blade 3/32" wide.

## SERVICING THE SET

Servicing "printed" circuit sets is, in general, much the same as servicing ordinary receivers. However, certain tools and techniques are well suited for this type of work. The following items are especially useful:

1. Good pair of long-nose pliers.
  2. Sharp wire cutters.
  3. Small stiff glue brush (for solder removal).
  4. Pencil type soldering iron with a small tip (35 watts or less).
- WARNING: Excessive heat may damage the "printed" circuit during component replacement if a soldering pencil, iron or gun of higher wattage rating is used.
5. 60-40 low temperature rosin core solder (should be used for all soldering).
  6. Tinned jumper wires.
  7. Metal pick (soldering aid).

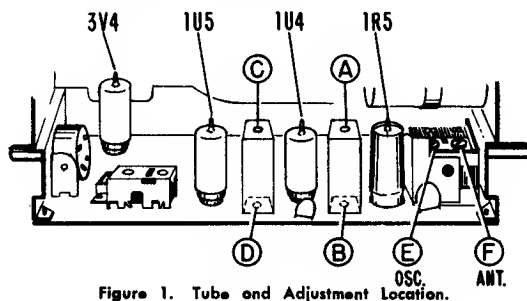

Figure 1. Tube and Adjustment Location.

## COMPONENT REPLACEMENT

All components used in this receiver are of standard size and design and are mounted on the top side of the chassis.

Resistors and capacitors should be replaced by clipping out the defective part and neatly soldering the new part to the connecting leads remaining from the original part.

If a unit, such as the oscillator coil or IF transformer is to be removed, heat the mounting lugs with a pencil type soldering iron and straighten them with a long nose pliers or metal pick. Continue heating the lugs and brush away the molten solder with a small stiff glue brush. Remove the defective unit by lifting it off the chassis. Before inserting the new unit, be certain that the lug holes are open and free from solder. Forcing a lug against a solder filled lug hole may break the bond between the chassis base and the "printed" wiring.

An open or damaged section of "printed" circuit wiring can be replaced by soldering a short jumper wire across the points to be connected.

To avoid need for complete tube socket replacement, defective tube socket pin clips may be replaced individually. Tube socket pin clips are available under part number 87A35-2.

Note: If sockets must be replaced, the tubular shield (center connection) at the bottom of each tube socket must be securely soldered to the "printed" circuit wiring, otherwise hum or oscillation will result.

# Admiral

**CHASSIS 4L2**  
**MODELS 4L21 • 4L24 • 4L25**  
**4L26 • 4L28**

**CHASSIS 4M2**  
**MODELS 4M22 • 4M23 • 4M25 • 4M28**

(Clock not used in Chassis 4L2 which has regular "on-off" switch)

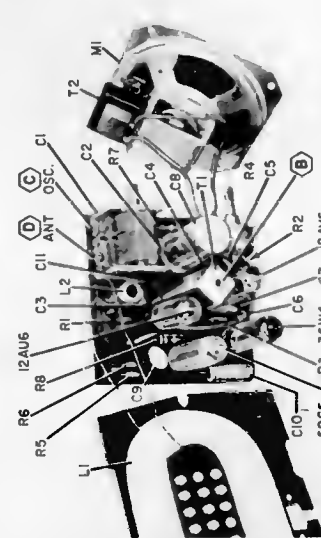
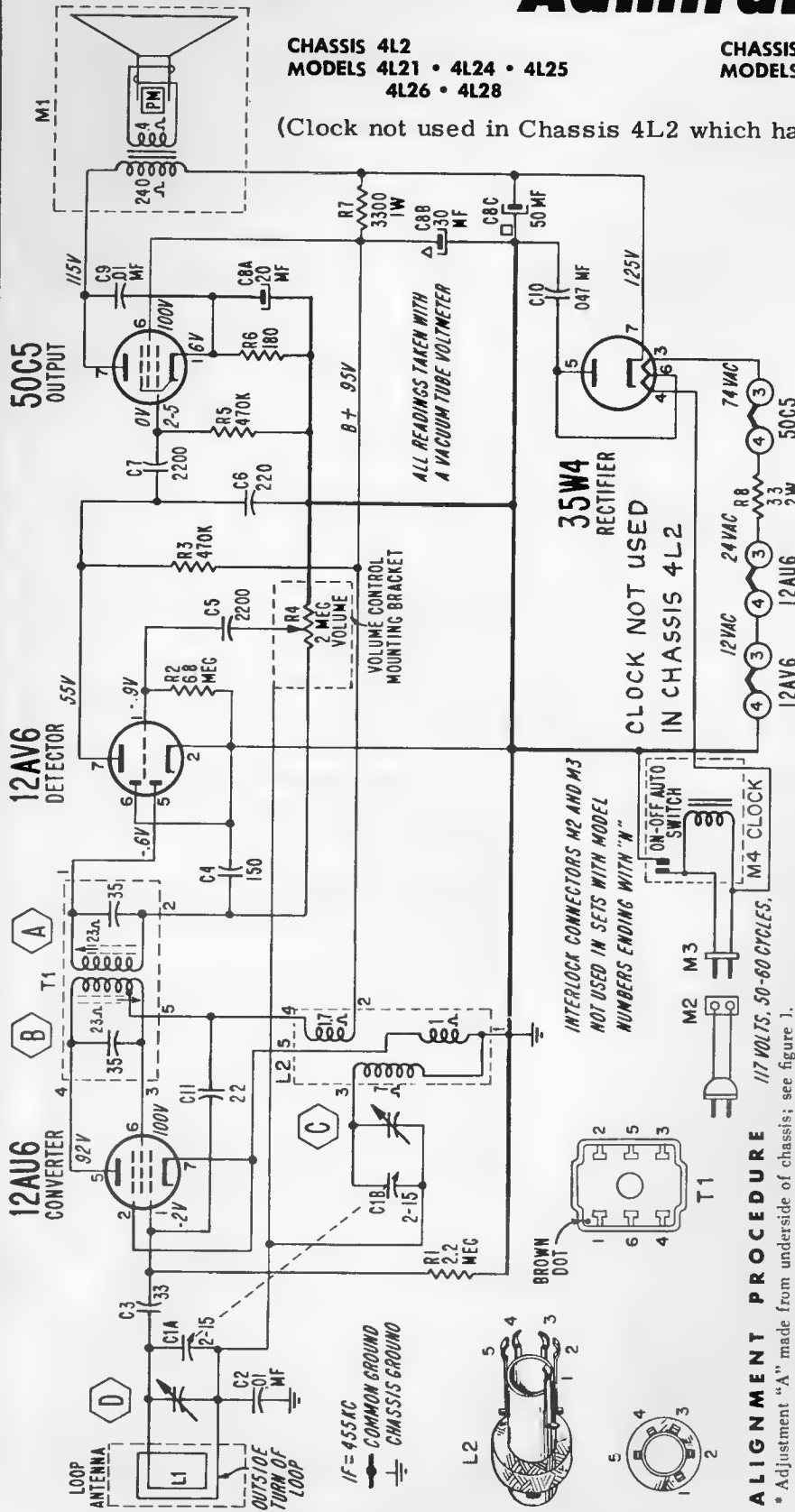

Top View of Chassis Showing Location of Components and Alignment Points.

STEP	CONNECTION OF SIGNAL GENERATOR	SIGNAL GENERATOR FREQUENCY	RECEIVER GANG SETTING	ADJUSTMENT
1	Through a .1 mf capacitor to pin 1 of the 12AU6 (Converter) tube	455 KC	Gang fully open	* "A" and "B" for maximum output
2	Same as "STEP 1"	1620 KC	Gang fully open	"C" for maximum output
3	Radiated Signal. Loop of several turns of wire, or place generator lead close to receiver loop for adequate signal pickup.	1400 KC	Tune in generator signal	"D" for maximum output

**ALIGNMENT PROCEDURE**

\* Adjustment "A" made from underside of chassis; see figure 1.

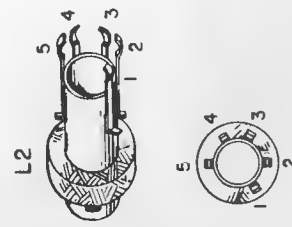

# Admiral Chassis 4N2

MODEL	COLOR	CHASSIS
HS3376	Mahogany	4N2
HS3377	Blond	4N2

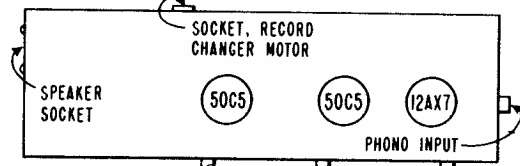
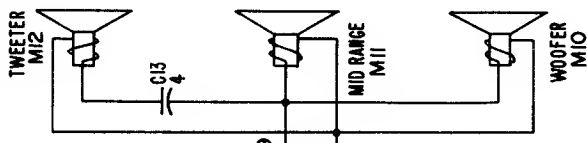

TUBE LOCATIONS

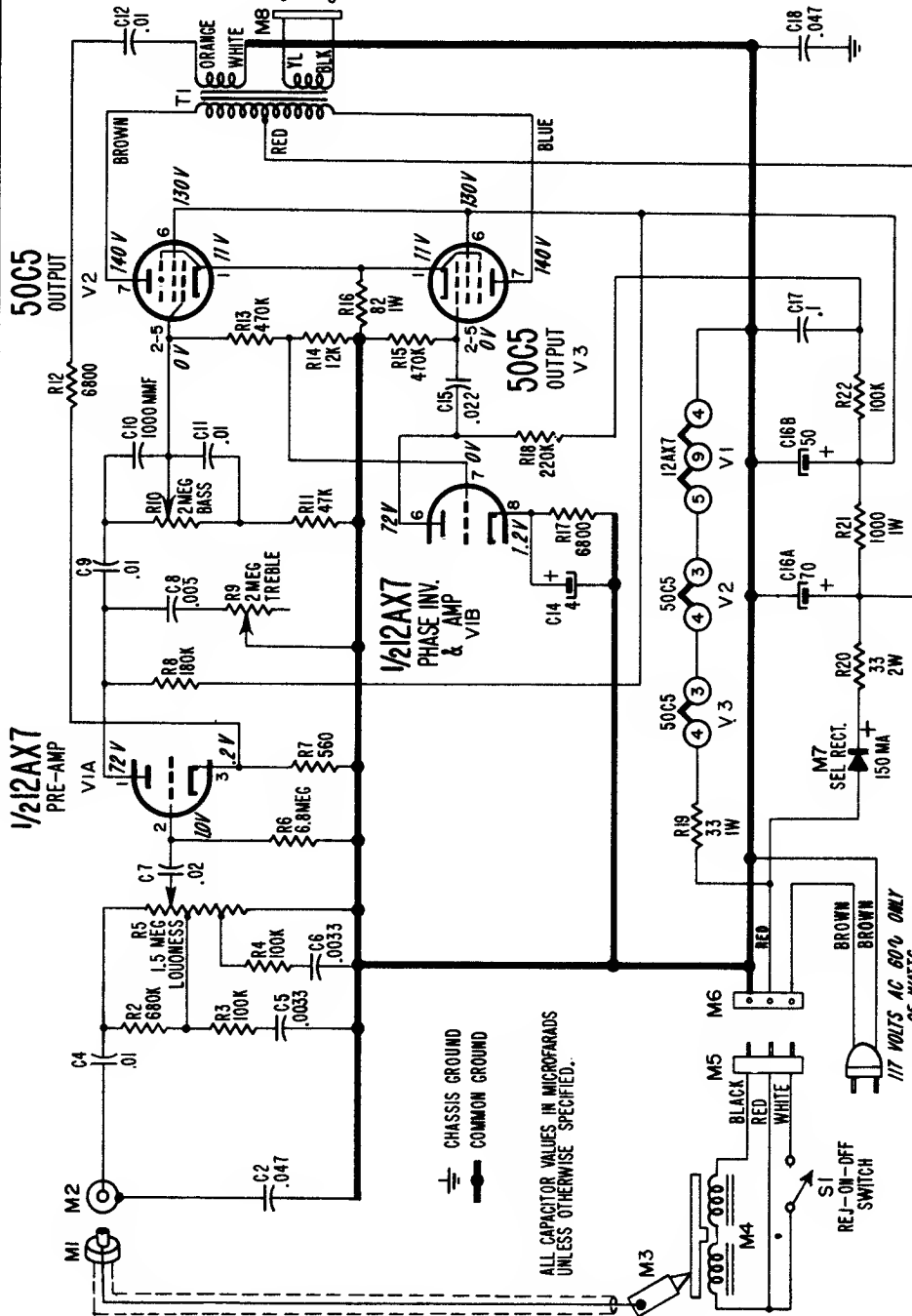

output plug (M9) from the chassis. Remove the Volume, Bass and Treble control knobs. Remove the four screws that mount the chassis and carefully lift the chassis.

To Remove the Record Changer:  
Disconnect the audio input plug (M1) and the record changer motor plug (M5) from the chassis. Remove the washer-head screws that mount the record changer while holding the record changer in place. Remove the record changer by lifting it free from the cabinet.

### TO REMOVE THE CHASSIS

After removing the line cord plug from the wall outlet, clamp the TONE ARM to the tone arm rest. Carefully turn the phono-graph upside down on a soft, padded surface. Remove the cabinet bottom mounting screws and lift the cabinet bottom and legs off the cabinet.

Disconnect the audio input plug (M1), the record changer motor plug (M5) and the audio

# Admiral Chassis 5M3A

MODELS 5M56 • 5M56B • 5M57 • 5M57B

## TUBE LOCATIONS

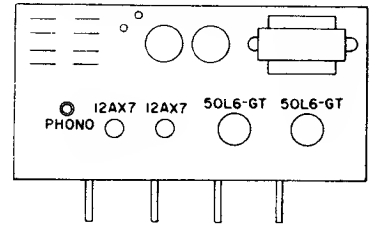

50L6GT  
V3

1/2 12AX7  
V2A

1/2 12AX7  
V1B

1/2 12AX7  
V1A

1/2 12AX7  
V2B

50L6GT  
V4

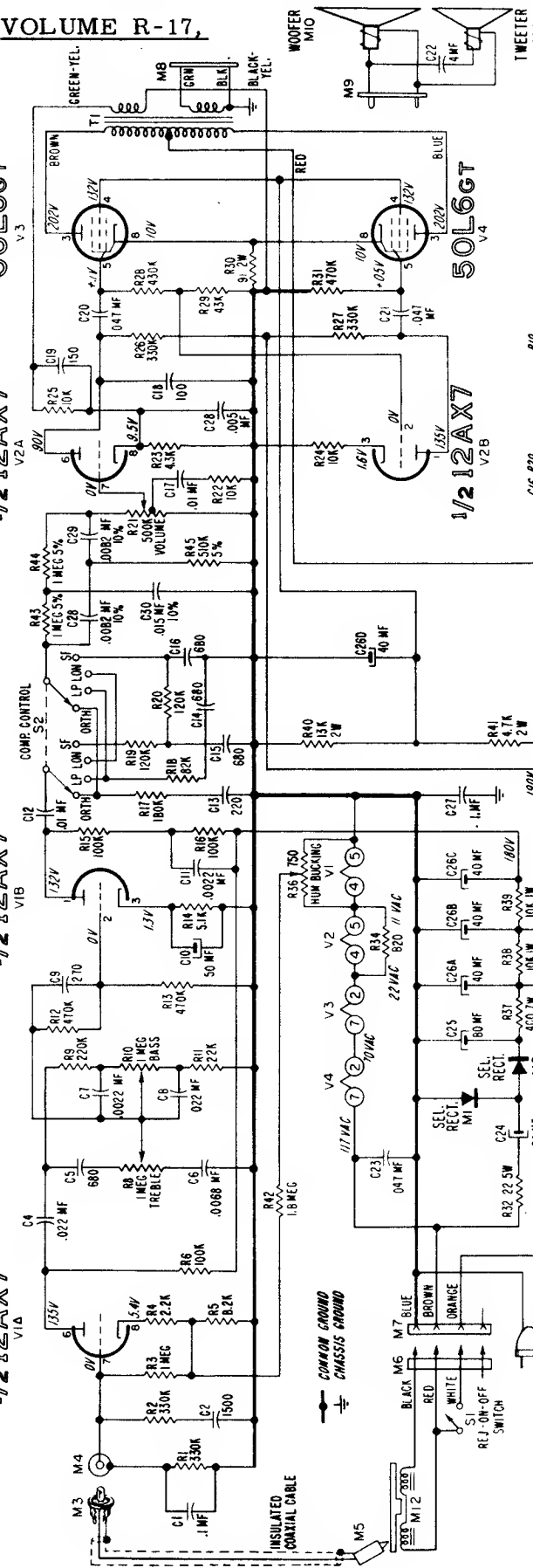

ALL VOLTAGE READINGS TAKEN WITH A VACUUM TUBE VOLTMETER

**To Remove the Record Changer:** Follow the procedure outlined under "TO REPLACE TUBES", and then proceed as follows:

Disconnect the audio input plug (M3) and the record changer motor plug (M6) from the chassis. Remove the three washer-head screws that mount the record changer while holding the record changer in place. Then remove the record changer by lifting it free from the cabinet.

**Service Note:** The "Rej-On-Off" switch (S1) on the record changer operates both amplifier and record changer motor. To operate the amplifier and record changer motor. To measure the amplifier and record changer voltages with the record changer disconnected, a short, temporary jumper wire must be connected between the brown and orange leads on socket "M7". See schematic.

Amplifier voltage readings may also be taken by connecting the record changer motor plug (M6) to the socket (M7) on the chassis. Unclamp the tone arm from the tone arm rest and move the "Rej-On-Off" switch to the "On" position.

### TO REPLACE TUBES

Remove the line cord plug from the wall outlet. To make tubes accessible for replacement, the cabinet back must be taken off by removing the cabinet back mounting screws.

**Caution:** The amplifier must be disconnected from the power source before attempting to remove tubes V1 (12AX7) and V2 (12AX7). Failure to observe this precaution will burn out resistors R34 and hum-bucking control R36; see schematic.

**To Remove the Chassis:** Follow the procedure outlined above under "TO REPLACE TUBES", and then proceed as follows:

Disconnect the audio input plug (M3), the record changer motor plug (M6) and the audio output plug (M9) from the chassis. Remove the four knobs from the controls on the chassis. Remove the four screws that mount the chassis and carefully lift the chassis from the cabinet.



# Admiral

# 7L1 Chassis

MODELS 7L12 • 7L14 • 7L16 • 7L18

(Alignment is on page 10, over)

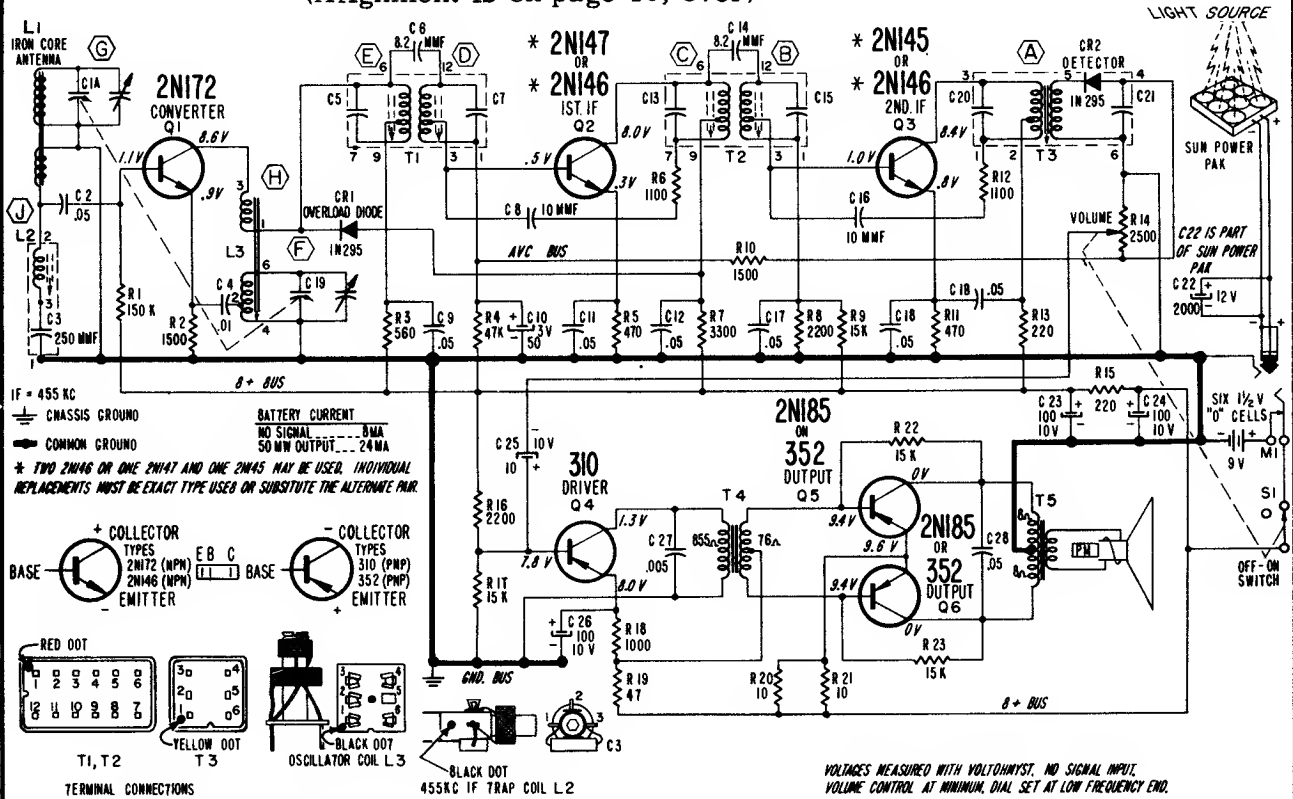

### BATTERY REPLACEMENT:

To install replacement batteries, remove the bottom section of the cabinet by rotating the plastic knob at the bottom of the cabinet one-third of a turn to the left. This frees the bottom section of the cabinet from the chassis, and the bottom section may be removed by pulling it away (down) from the top section.

To remove worn out batteries, first remove the wing screw at the right of the battery compartment. Move the "L-shaped" battery contact bracket aside, being careful not to exert any undue strain on its connecting wires. Then slide the batteries out.

When installing new batteries, be sure that the positive terminal of each battery faces in the direction indicated by the arrows stamped in the battery compartment. The batteries rest in the battery compartment in two rows. The bottom row have their positive terminal facing toward the gang, the top row have their positive terminal facing toward the Off-On-Volume control. Six batteries connected in series provide 9 volts of power to operate the set.

In normal use, batteries for this set should furnish about 700 operating hours.

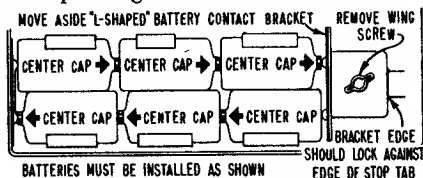

### REMOVING THE CHASSIS

To remove the chassis from the cabinet top section, proceed as follows:

1. Remove Off-On-Volume and Tuning control knobs.
2. Remove 4 screws mounting cabinet top section to chassis (2 on each side of cabinet top section).
3. Remove Sun Power Pak receptacle at rear of cabinet top section by removing hex nut and washer fastening receptacle to cabinet. Then carefully push receptacle free of its mounting hole.
4. Carefully lift cabinet top section up and toward the rear of the cabinet. Be careful not to exert any undue strain on connecting leads.

To service the component side of the printed wiring board, it will be necessary to remove the bottom section of the cabinet. Follow procedure outlined under "Battery Replacement".

### TESTING TRANSISTORS

The transistors used in this set are junction type. This type of transistor is more apt to become shorted than open. A shorted transistor will cause a resultant increase in current drain of the power supply. Thus a quick check is to measure the current drain with a milliammeter connected in series with the leads from the power supply. Normal current drain with no signal will be approximately 8 milliamperes. Transistors often become shorted because of excessive current flow, usually indicative of circuit trouble. If a transistor is found to be shorted, check the circuit carefully before installing a new one.

# Admiral

CHASSIS 7L1  
 MODELS 7L12 • 7L14 • 7L16 • 7L18

## ALIGNMENT PROCEDURE

- Fresh batteries should be used when making an alignment.
- Set Volume control full on.
- Connect output meter across speaker voice coil.
- Use lowest setting of signal generator capable of producing adequate indication on lowest scale of output meter (maintain setting of .3 volt (25 mw) or less).
- Use a non-metallic alignment tool for IF transformers.
- Repeat adjustments to insure good results.
- Radio should be aligned while chassis is in cabinet top section.
- Antenna in "pop-up" position and rotated 90° (perpendicular to cabinet front).

Step	Connection of Signal Generator	Signal Generator Frequency	Receiver Gang Setting	Adjustment Description	Adjustment
Disconnect 455 KC trap, or short capacitor C3 with clip lead.					
1	Radiated Signal Loop of several turns of wire, or place generator lead close to receiver for adequate signal pickup.	455 KC	Gong fully open	3rd IF 2nd IF 1st IF	"A, B, C, D, and E" for maximum output

Repeat Step 1 several times until there is no further increase in the output. Reconnect 455 KC Trap.

2	Same as "STEP 1".	455 KC	Gong fully open	455 KC Trap	"J" for minimum output
3	Same as "STEP 1".	1620 KC	Gong fully open	Oscillator Trimmer	"F" for maximum output
4	Same as "STEP 1".	1400 KC	Tune in generator signal	Antenna Trimmer *(Rock Gong)	"G" for maximum output

NOTE: DO NOT perform the following steps unless you are unable to tune in 535 KC. BEFORE PROCEEDING, SET OSCILLATOR TRIMMER ¼ TURN FROM ITS TIGHT POSITION.

5	Same as "STEP 1".	535 KC	Gong fully open	Oscillator Core	"H" for maximum output
6	Same as "STEP 1".	1620 KC	Gang fully open	Oscillator Trimmer	"F" for maximum output
7	Repeat Steps 5 and 6 until oscillator covers required range; Step 6 should be lost adjustment.				
8	Same as "STEP 1".	1400 KC	Tune for maximum	Antenna Trimmer	"G" for maximum output

To avoid splitting the slotted head of powdered iron tuning slug in IF transformers, use an alignment tool with a blade 3/32" wide.

\*Antenna trimmer "C" should first be adjusted for maximum output. Then try to increase output further by rotating gang slightly; alternately in each direction (rocking), and readjusting trimmer "C" for maximum output.

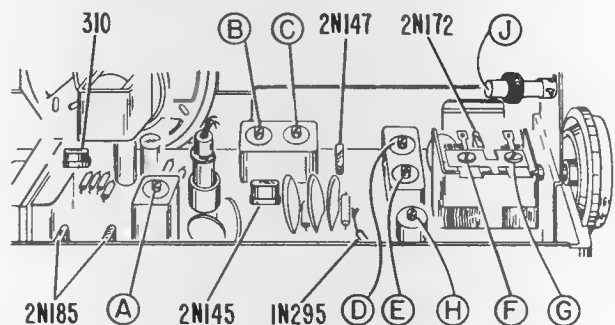
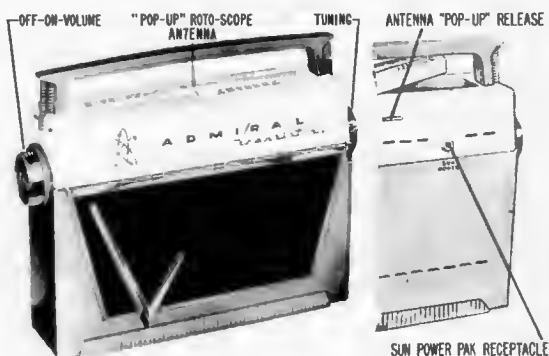

(See page 9, preceding, for circuit diagram and other data)

**Arvin INDUSTRIES, INC.**

Model 2563, Chassis 1.40300, and  
Model 2564, Chassis 1.40400

Also sold as Sears, Roebuck Chassis 132.39900, Models 7006, 7007

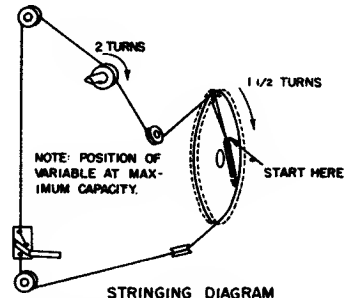
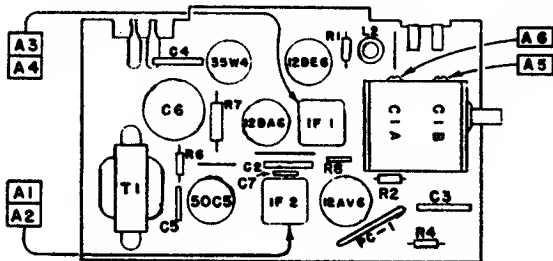

**ALIGNMENT PROCEDURE**

- Output meter connection ..... Across speaker voice coil
- Connection of generator ground lead ..... Floating ground
- Position of volume control ..... Fully clockwise

Position of Variable	Frequency of Generator	Dummy Antenna	Generator Output Connection	Trimmers Adjusted in order Shown for Maximum Output	Functions of Trimmer
Open	455	.05 $\mu$ f	Pin 7 12BE6	A1, A2, A3, A4	I. F.
Open	1670		* Test Loop	A5	Oscillator
1400	1400		* Test Loop	A6	Antenna
600	600		* Test Loop	Check Point	

\* Standard Hazeltine Test Loop Model 1150 or 3 turns of wire about 6" in diameter placed about one foot from the set loop.  
The alignment procedure should be repeated in the original order for greatest accuracy. Always keep the output from the signal generator at its lowest possible value to make the AVC action of the receiver ineffective.

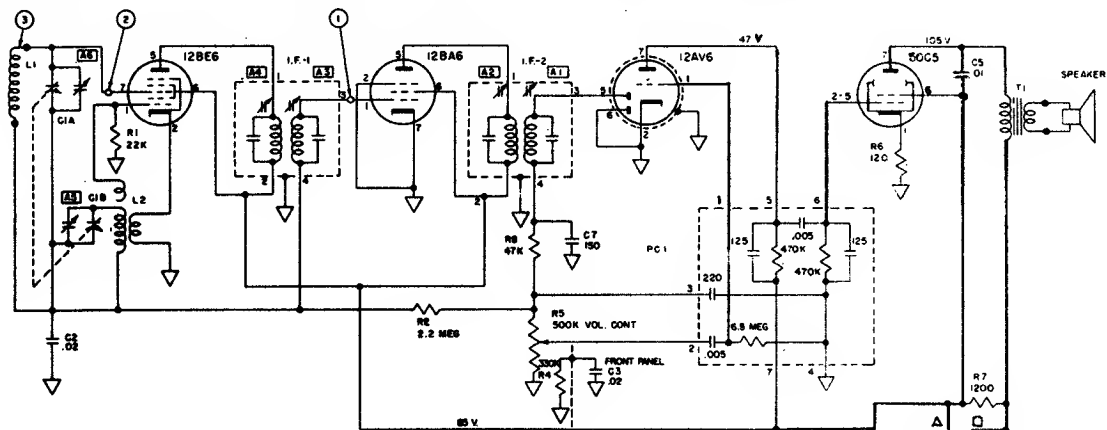

⊙ - EXTERNAL CONNECTIONS TO PRINTED BOARD.  
VOLTS MEASURED WITH A V.T.V.M.

RESISTANCE VALUES ARE IN OHMS K=1,000, MEG=1,000,000.  
CAPACITANCE VALUES LESS THAN (1) ARE IN MICROFARADS ( $\mu$ F),  
AND VALUES OF (1) OR GREATER ARE IN MICROFARADS ( $\mu$ F),  
UNLESS OTHERWISE INDICATED.

APPROXIMATE SENSITIVITIES

CIRCUIT POINT	DUMMY INPUT FOR .05 WATT OUTPUT (0.4 VOLTS ACROSS VC1)	INPUT FOR 5 WATT OUTPUT (1.25 VOLTS ACROSS VC1)
1	20 $\mu$ F AT 455 KC	2000 $\mu$ V
2	20 $\mu$ F AT 455 KC	50
3	STANDING LOOP AT 1000 KC	200V/M

**Arvin INDUSTRIES, INC.**

Model 3561, Chassis 1.40600

Also sold as Sears, Roebuck Chassis 132.40100, Models 7013, 7014

**ALIGNMENT PROCEDURE**

Output meter connection . . . . . Across speaker voice coil  
 Connection of generator ground lead . . . . . Floating ground  
 Position of volume control . . . . . Fully clockwise

Position of Variable	Frequency of Generator	Dummy Antenna	Generator Output Connection	Trimmers Adjusted in order Shown for Maximum Output	Functions of Trimmer
Open	455	.05 $\mu$ f	Pin 7 12BE6	A1, A2, A3, A4	I. F.
Open	1670		* Test Loop	A5	Oscillator
1400	1400		* Test Loop	A6, A7	R. F., Ant.
600	600		* Test Loop	Check Point	

\* Standard Hazeltine Test Loop Model 1150 or 3 turns of wire about 6" in diameter placed about one foot from the set loop.  
 The alignment procedure should be repeated in the original order for greatest accuracy. Always keep the output from the signal generator at its lowest possible value to make the AVC action of the receiver ineffective.

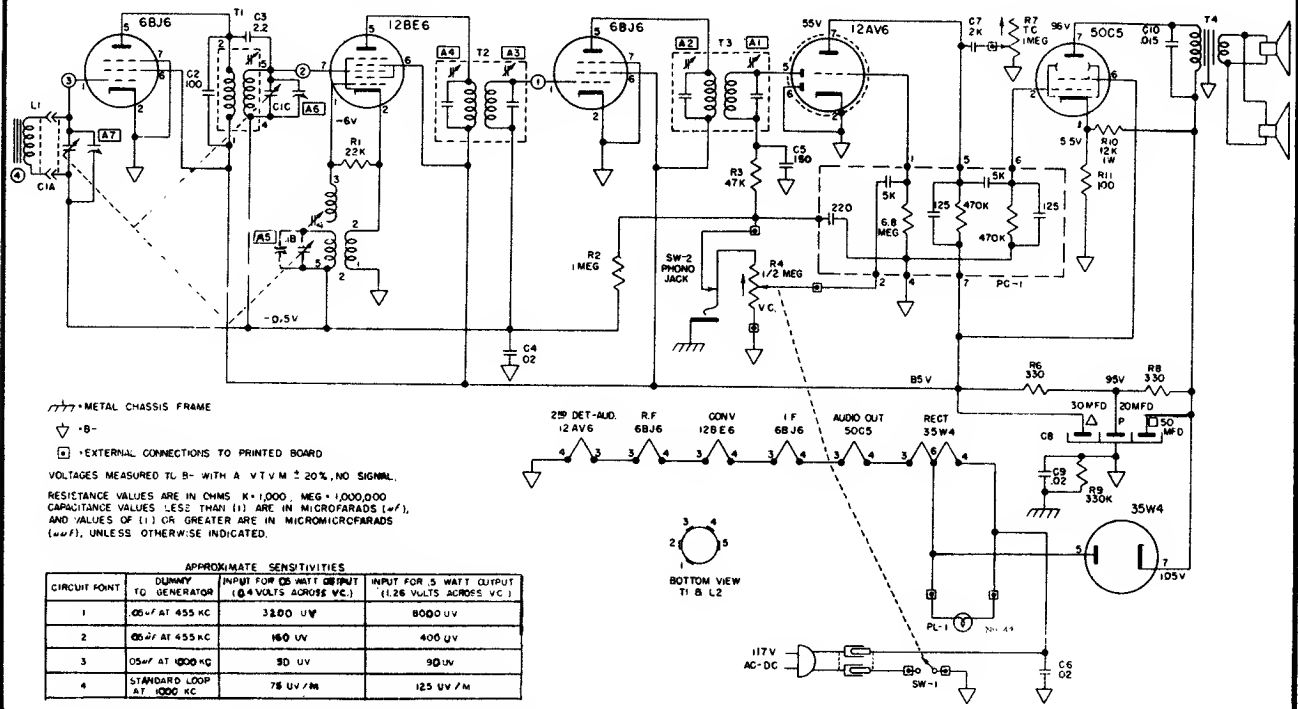
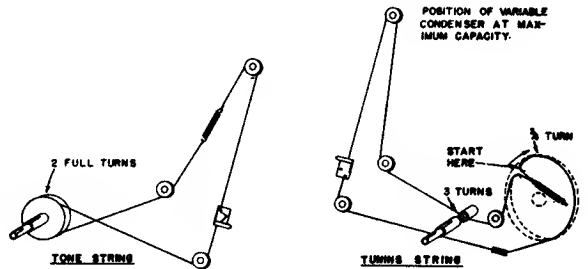
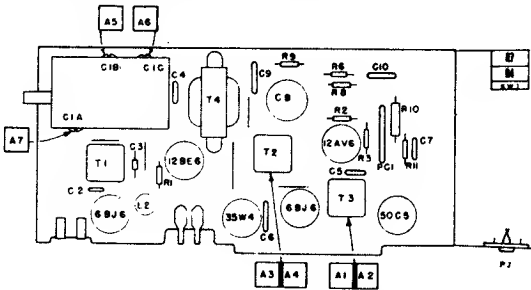

--- METAL CHASSIS FRAME  
 -B-  
 [ ] EXTERNAL CONNECTIONS TO PRINTED BOARD  
 VOLTAGES MEASURED TO B- WITH A VTVM  $\pm$  20%, NO SIGNAL.  
 RESISTANCE VALUES ARE IN OHMS K=1,000, MEG=1,000,000  
 CAPACITANCE VALUES LESS THAN (1) ARE IN MICROFARADS ( $\mu$ f),  
 AND VALUES OF (1) OR GREATER ARE IN MICROMICROFARADS  
 ( $\mu\mu$ f), UNLESS OTHERWISE INDICATED.

APPROXIMATE SENSITIVITIES

CIRCUIT POINT	DUMMY TO GENERATOR	INPUT FOR 5 WATT OUTPUT (1.28 VOLTS ACROSS VC.)	INPUT FOR 5 WATT OUTPUT (1.28 VOLTS ACROSS VC.)
1	.05 $\mu$ f AT 455 KC	3200 $\mu$ V	8000 $\mu$ V
2	.05 $\mu$ f AT 455 KC	160 $\mu$ V	400 $\mu$ V
3	.05 $\mu$ f AT 1000 KC	90 $\mu$ V	90 $\mu$ V
4	STANDARD LOOP AT 1000 KC	75 $\mu$ V / M	125 $\mu$ V / M

ARVIN Industries Model 8565, Chassis 1.41200

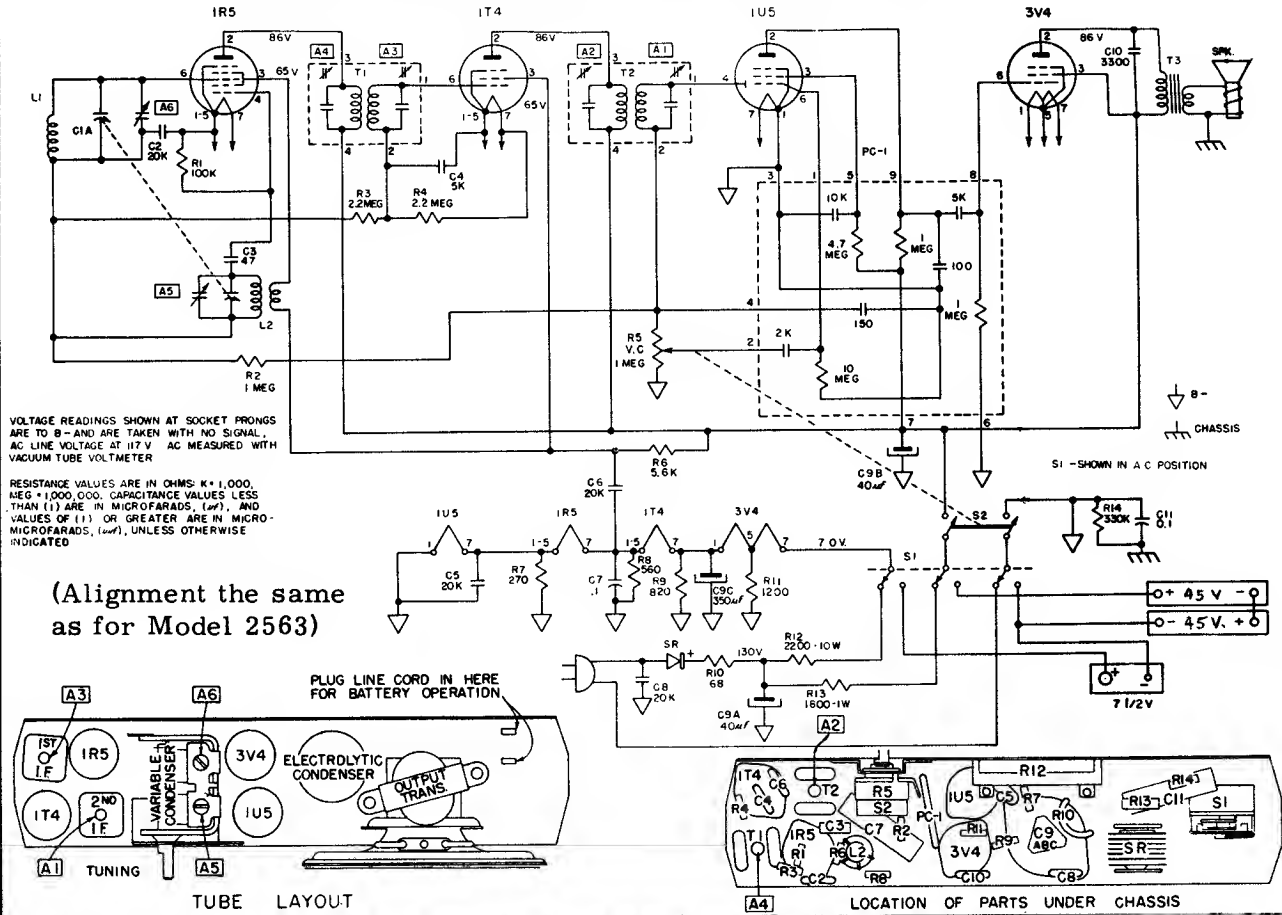

ARVIN Industries Model 5561, Chassis 1.40800

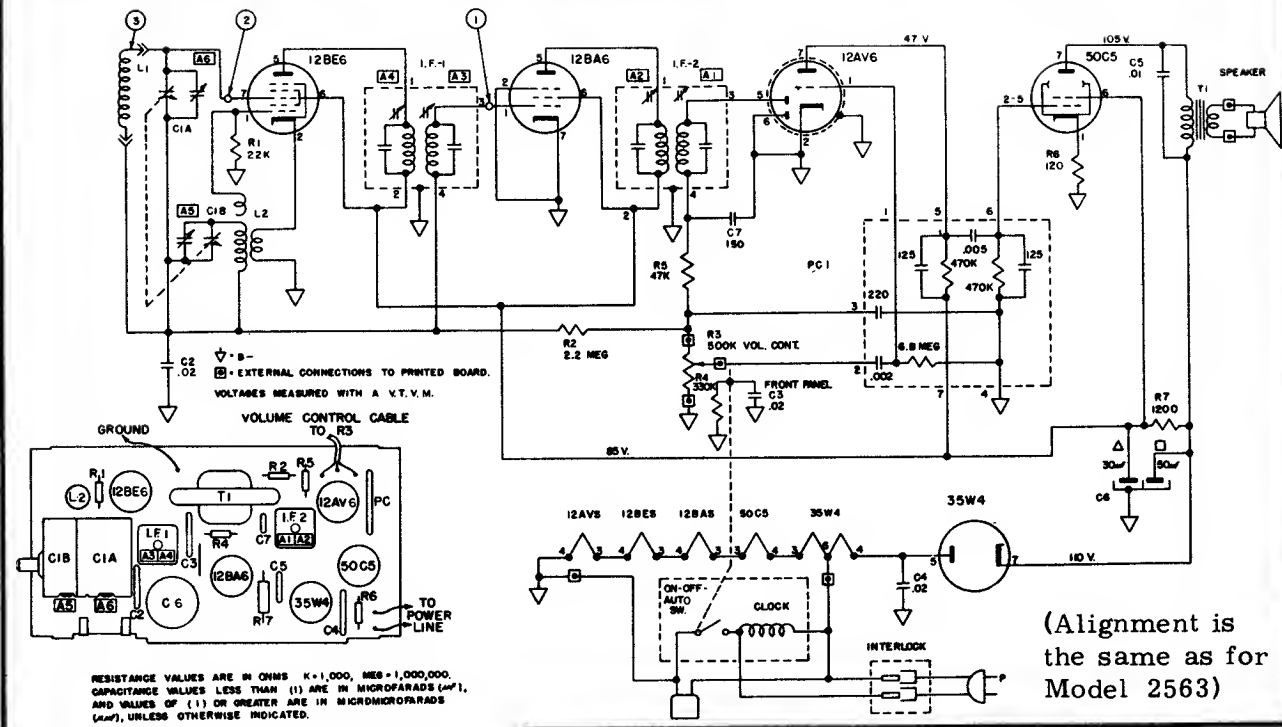

# Arvin INDUSTRIES, INC.

Model 9562, Chassis 1.40900

Output meter reading to indicate 50 milliwatts ..... 0.4V  
 Output meter connection ..... Across speaker voice coil  
 Connection of generator ground lead ..... Common Ground  
 Generator Modulation ..... 30% 40 cycles  
 Position of volume control ..... Fully Clockwise

Position of Variable	Generator Frequency	Dummy Antenna	Generator Connections	Trimmers Adj. in order shown for Max. Output	Function of Trimmer
Open	455 Kc	.05 $\mu$ f	C1A	A1, 2, 3, 4	I. F.
Open	1670 Kc		*Test Loop	A6	Oscillator
1400Kc	1400 Kc		*Test Loop	A7	Antenna
600Kc	600 Kc		*Test Loop	Check Point	

\*Standard Hazeltine Test Loop Model 1150 or 3 turns of wire about 6" in diameter placed about one foot from the set loop.

The alignment procedure should be repeated in the original order for greatest accuracy. Always keep the output from the signal generator at its lowest possible value to make the AVC action of the receiver ineffective.

**WARNING:** Since a DC voltage exists across the oscillator section (C1B) of the variable capacitor, it is recommended that the plates in this section not be adjusted unless absolutely necessary for calibration purposes.

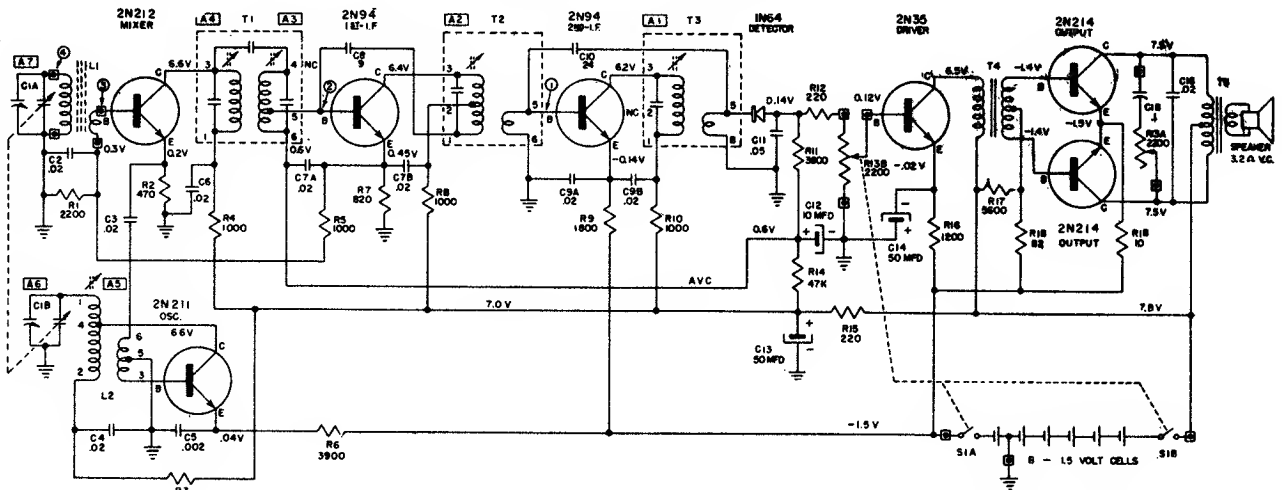

POSITION WITH VARIABLE AT MAXIMUM CAPACITY

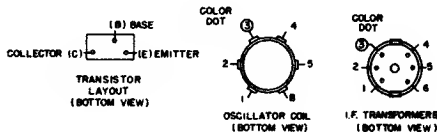

RESISTANCE VALUES ARE IN OHMS: K = 1000.  
 CAPACITANCE VALUES LESS THAN 10 ARE IN MICROFARADS ( $\mu$ F), AND VALUES GREATER THAN 10 ARE IN MICRO-MICROFARADS ( $\mu\mu$ F) EXCEPT WHERE NOTED.

VOLTAGE READINGS TO COMMON GROUND ARE MEASURED WITH VACUUM TUBE VOLTMETER UNDER NO SIGNAL CONDITIONS WITH TUNING CAPACITOR CLOSED AND VOLUME CONTROL AT MAXIMUM CLOCKWISE ROTATION.

⊕ COMMON GROUND SYMBOL.

□ EXTERNAL CONNECTION TO PRINTED CIRCUIT

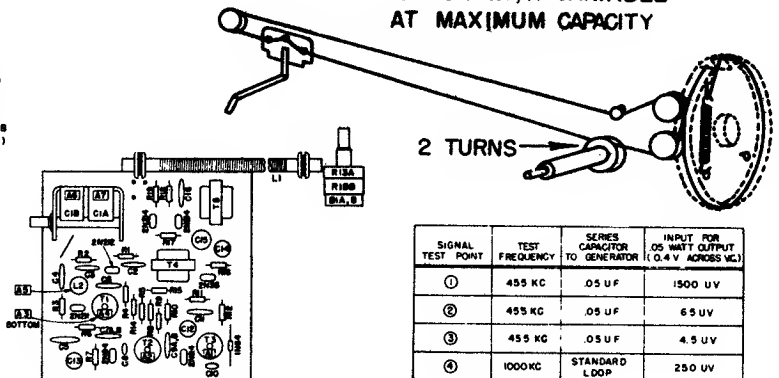

SIGNAL TEST POINT	TEST FREQUENCY	SERIES CAPACITOR TO GENERATOR (0.4 V ACROSS VC)	INPUT FOR .05 WATT OUTPUT
①	455 KC	.05 $\mu$ F	1500 $\mu$ V
②	455 KC	.05 $\mu$ F	6.5 $\mu$ V
③	455 KC	.05 $\mu$ F	4.5 $\mu$ V
④	1000 KC	STANDARD LOOP	250 $\mu$ V

# CBS

CBS-COLUMBIA

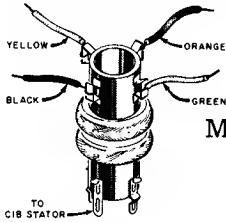

Chassis 616, Model C240,  
Chassis 636, Models C230, C231, C232,  
Chassis 656, Model C220.

Material on pages 15 and 16; separate diagrams shown for each chassis.

## Alignment

Set volume control to maximum. Adjust output of signal generator no higher than

*Oscillator Coil, all Chassis* necessary for satisfactory indication. Use an insulated alignment tool.

Step	Signal Generator		Receiver Tuning	Output Meter Connection	Adjust
	Freq.	Connect to			
1	455KC MOD.	Pin 1 of V2, 12BA6, thru .05 mf	Minimum capacity	Across voice coil	T2, top and bottom slugs, for maximum indication.
2	As above	Pin 7 of V1, 12BE6, thru .05 mf	As above	As above	T1, top and bottom slugs, for maximum indication.
3	1620KC MOD.	As above	As above	As above	C1B, oscillator trimmer, for maximum indication.
4	1400KC MOD.	Couple inductively to loop antenna	For maximum signal	As above	C1A, antenna trimmer, for maximum indication.

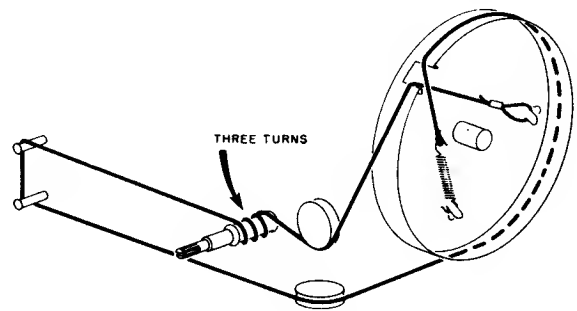
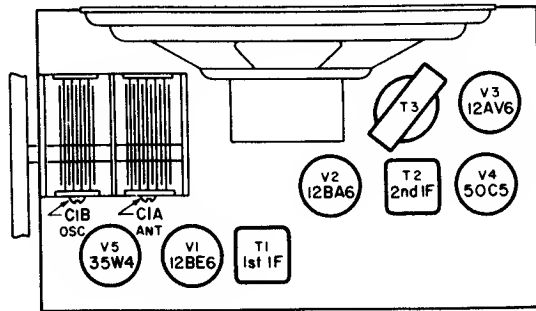

Tube and Trimmer Locations

Dial Stringing.

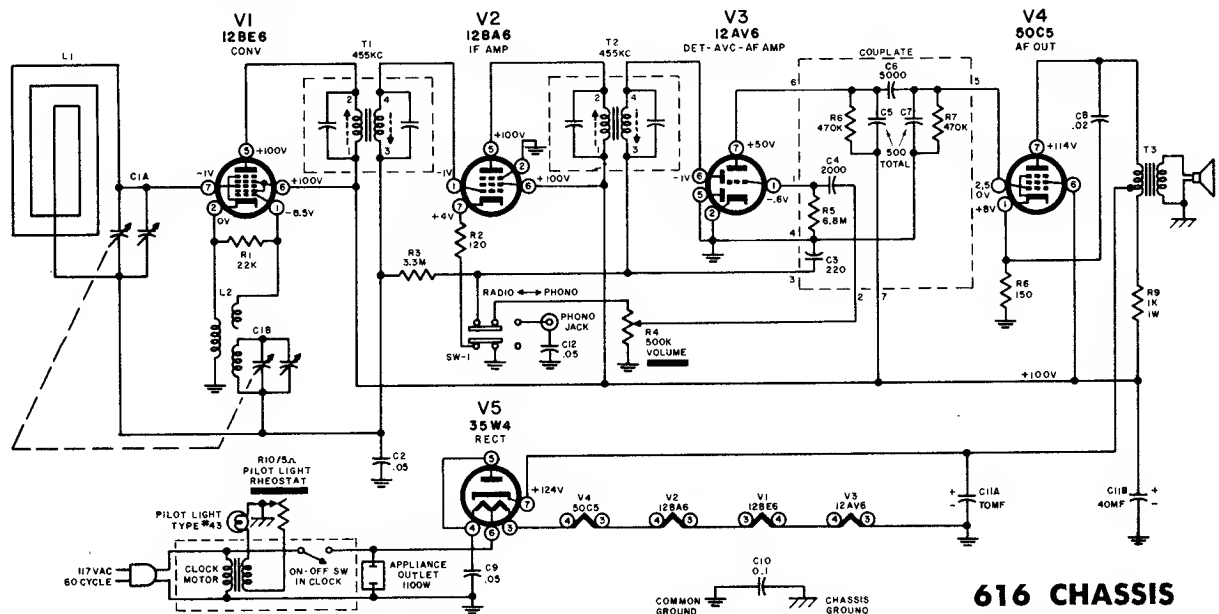

616 CHASSIS

VOLUME R-17, MOST-OFTEN-NEEDED 1957 RADIO SERVICING INFORMATION

CBS-COLUMBIA Chassis 616, 636, 656, Models C220, C230, C231, C232, C240  
(Continued from page 15; separate diagrams; other data for all chassis)

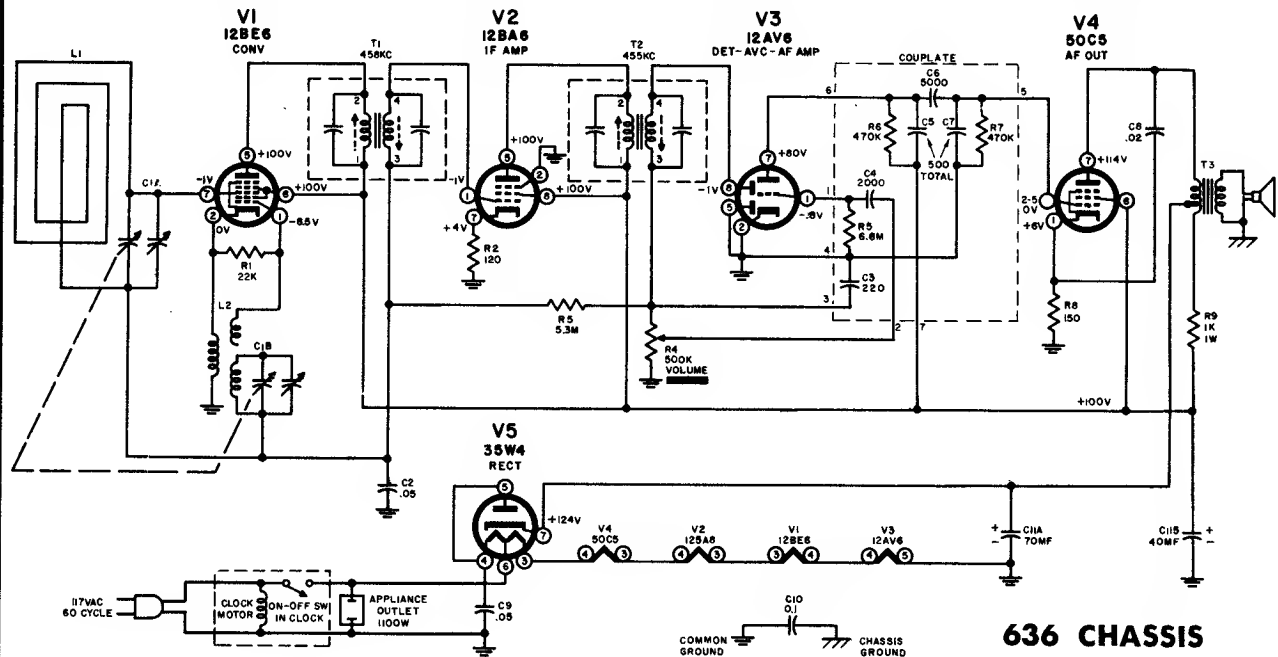

636 CHASSIS

Notes

1. Voltages taken with VTVM from tube socket terminals to common ground (not chassis). Tuning capacitor set to minimum.
2. Capacitor values less than one are microfarads, and values greater than one are micro-microfarads, unless otherwise indicated.
3. Resistors are 1/2W, 10% unless otherwise indicated. K = X1,000; M = X1,000,000.
4. When using AC operated test equipment, connect an isolation transformer between the chassis and the power line.

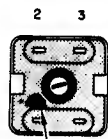

IF Trans, all Chassis

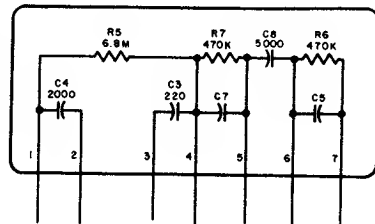

Couplate, all Chassis

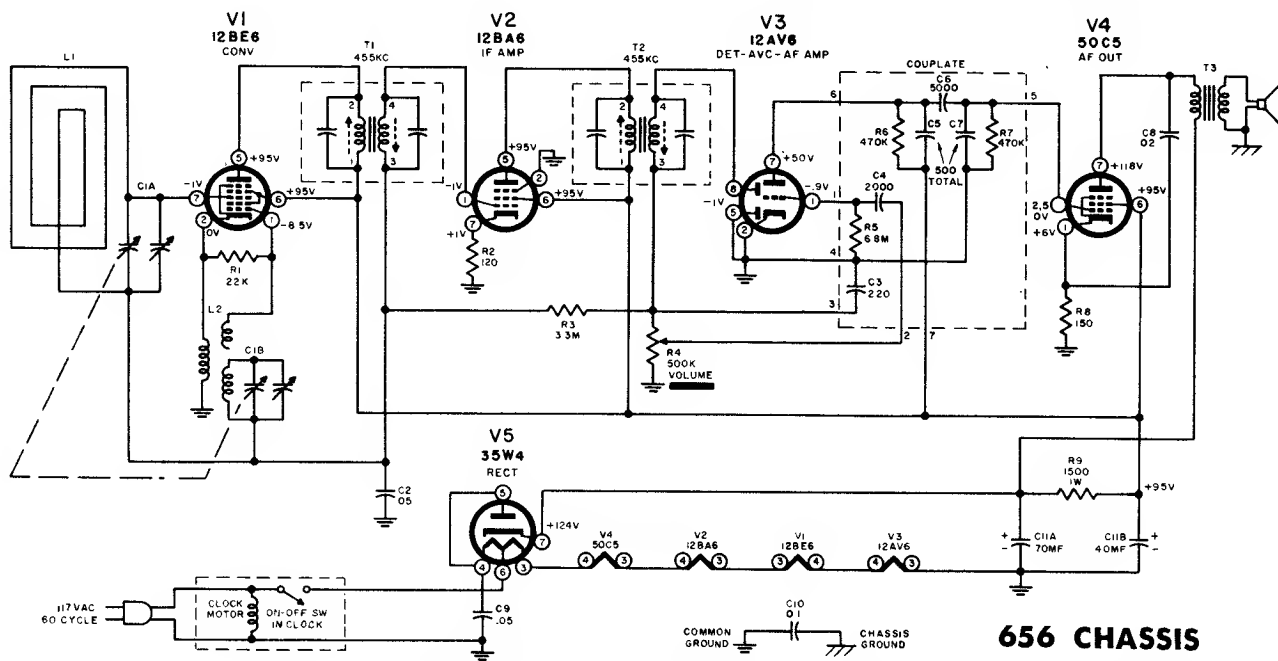

656 CHASSIS



# CROSLEY

## CHASSIS 5060P

Models: P-50BG,  
P-50BK, P-50WE

Models: P-60GY  
P-60RD, P-60BE, P-60PK

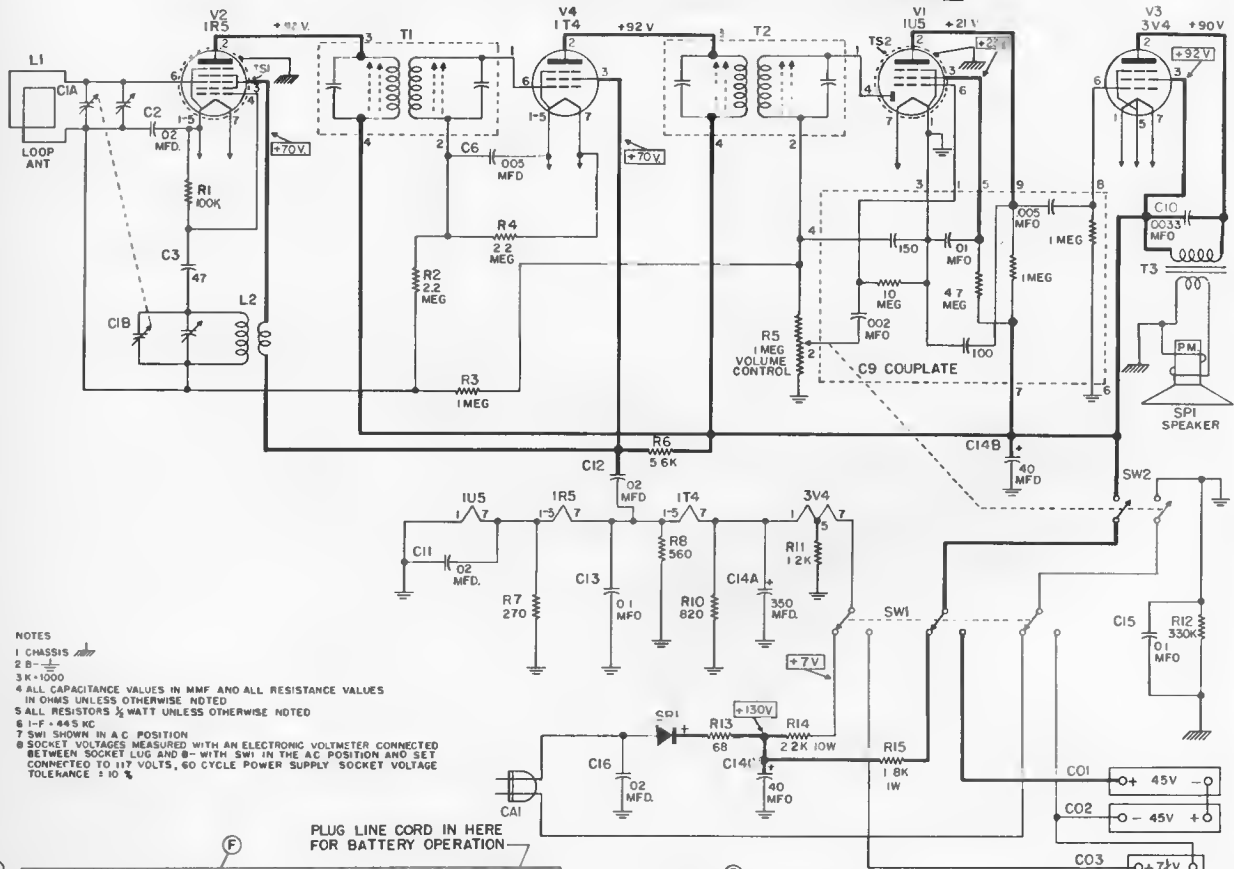
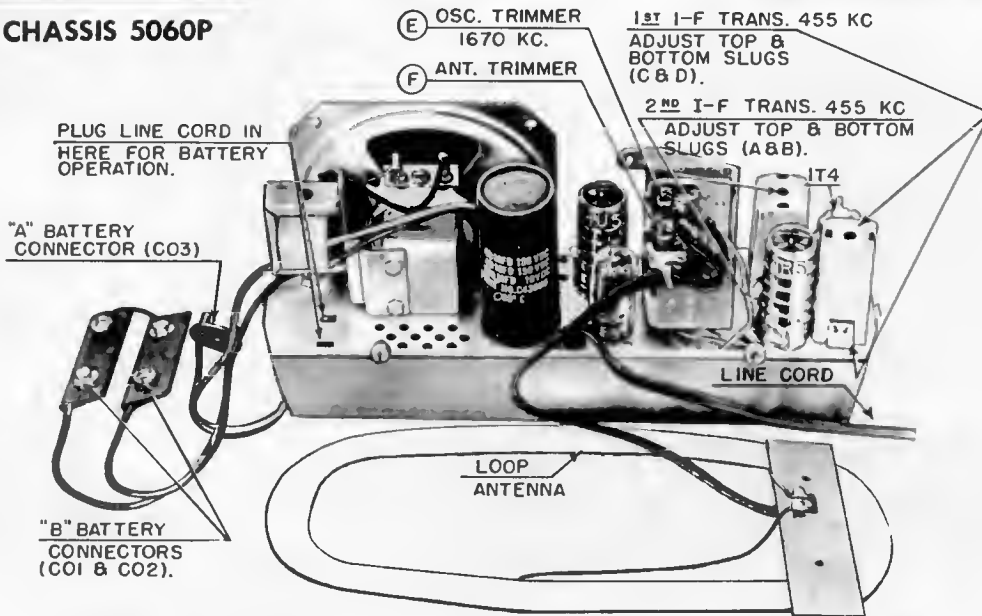

NOTES

- 1 CHASSIS
- 2 B-  $\frac{1}{2}$
- 3 K-1000
- 4 ALL CAPACITANCE VALUES IN MMF AND ALL RESISTANCE VALUES IN OHMS UNLESS OTHERWISE NOTED
- 5 ALL RESISTORS  $\frac{1}{2}$  WATT UNLESS OTHERWISE NOTED
- 6 I-F = 445 KC
- 7 SW1 SHOWN IN A.C. POSITION
- 8 SOCKET VOLTAGES MEASURED WITH AN ELECTRONIC VOLTMETER CONNECTED BETWEEN SOCKET LUG AND B- WITH SW1 IN THE A.C. POSITION AND SET CONNECTED TO 117 VOLTS, 60 CYCLE POWER SUPPLY SOCKET VOLTAGE TOLERANCE  $\pm 10\%$

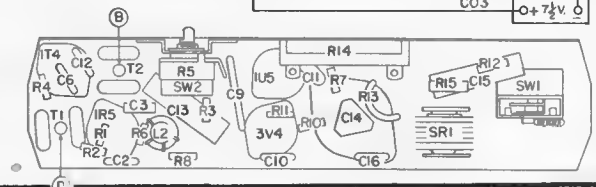
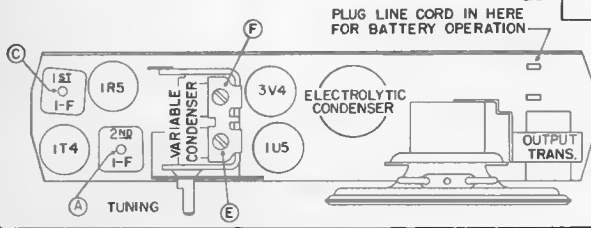

# CROSLEY

## CHASSIS 41T

Models: T-41BK, T-41GN T-41RD  
T-41GY, T41IY

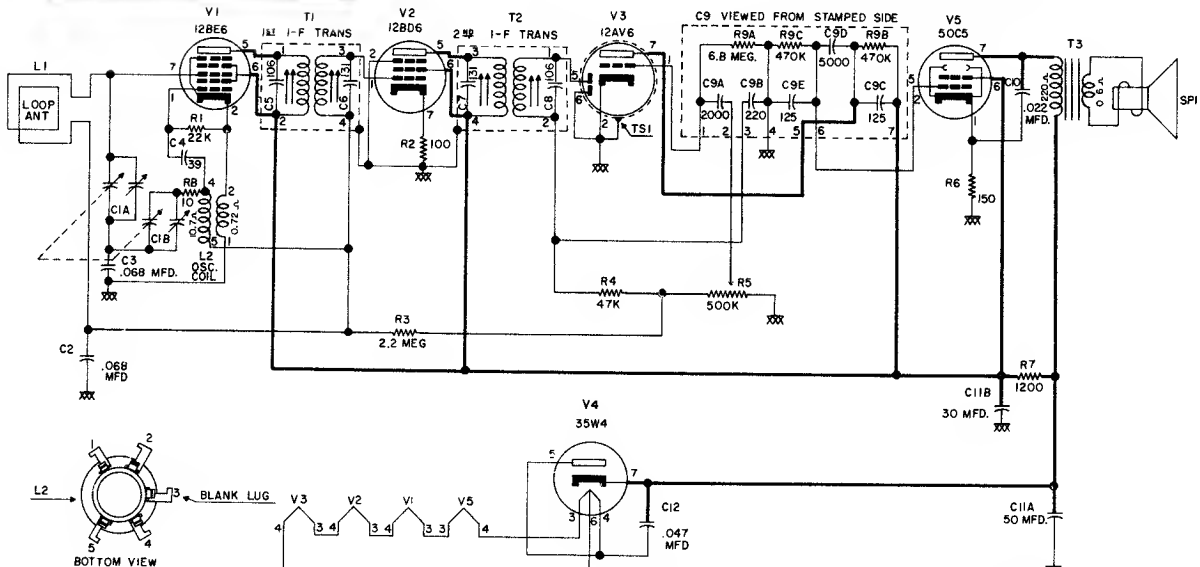

### ALIGNMENT PROCEDURE

1. Remove chassis from the cabinet.
2. Connect an output meter across the speaker voice coil (3.2 ohms) terminals.
3. Feed an R-F signal modulated 30% at 400 cycles to the receiver, as indicated in the alignment chart. Connect signal generator through dummy antenna to mixer grid when aligning I-F transformers, and radiate signal to loop antenna when making the oscillator and antenna trimmer adjustment.
4. Turn the Volume Control to maximum clockwise position and adjust the signal generator output to produce approximately mid-scale deflection of the output meter, but maintain signal generator output as low as possible to prevent AVC action.

NOTES  
K = 1000, ALL TOLERANCES 20% UNLESS OTHERWISE NOTED.  
ALL RESISTANCE VALUES IN OHMS & CAPACITANCE VALUES IN MMF. UNLESS OTHERWISE NOTED.  
NUMBER ONE TERMINAL OF I-F TRANSFORMERS CODED WITH GREEN DOT, NUMBERS PROGRESS CLOCKWISE.  
I-F = 455 KC  
XXX = COMMON WIRING.

### DUMMY ANTENNA

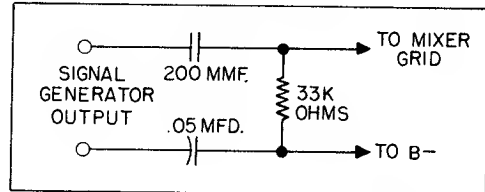

Additional service material on the next page adjacent at right.

### ALIGNMENT CHART

Alignment	Signal Generator Output			Position of Tuning Gang	Adjust for Max. Output	Remarks
	Freq. in KC.	In Series With	TO			
1	455	Dummy Antenna	Mixer grid pin 7 of V1	Open	A & B	
2	455	Dummy Antenna	Mixer grid pin 7 of V1	Open	C & D	
3	Repeat steps 1 and 2 until maximum output is obtained.					See note 1
4	1620	Radiated Sig.	Antenna	Open	E	See note 2 & 3
5	1400	Radiated Sig.	Antenna	Tune in Signal	F	See note 2 & 3

1. Remove dummy antenna and reconnect loop antenna (yellow wire to inside of loop winding).
2. Loop antenna should be positioned with respect to cabinet and chassis so that no further adjustment is required when chassis is placed in the cabinet.
3. The signal can be radiated to the antenna by placing the output lead of the signal generator close to the loop antenna.

VOLUME R-17, MOST-OFTEN-NEEDED 1957 RADIO SERVICING INFORMATION

CROSLLEY Chassis 41T (Continued from previous page)

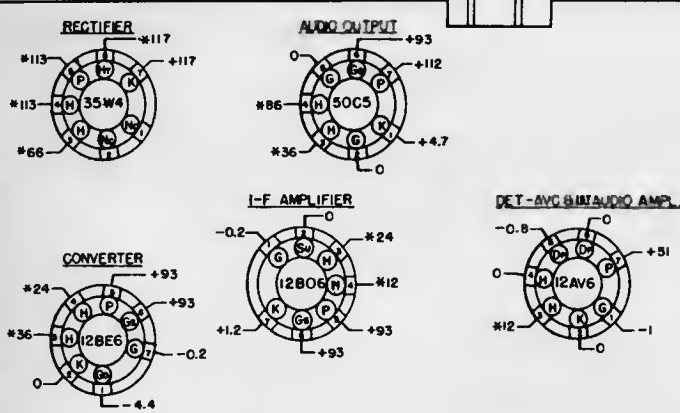

- NOTES:  
 1. BOTTOM VIEW OF TUBE SOCKETS  
 2. VOLTAGES MEASURED WITH AN ELECTRONIC VOLTMETER FROM SOCKET LUG TO B-  
 3. MEASURED WITH THE VOLUME CONTROL AT MINIMUM & NO SIGNAL INTO THE LOOP, TUNING GANG CLOSED.  
 4. W.J. = WIRING JUNCTION.  
 \* = AC VOLTAGES, NC = NO CONNECTION.  
 5. LINE VOLTAGE = 117V. 60 CYCLES.  
 6. SOCKET VOLTAGE TOLERANCE ± 10%.

SOCKET VOLTAGE CHART

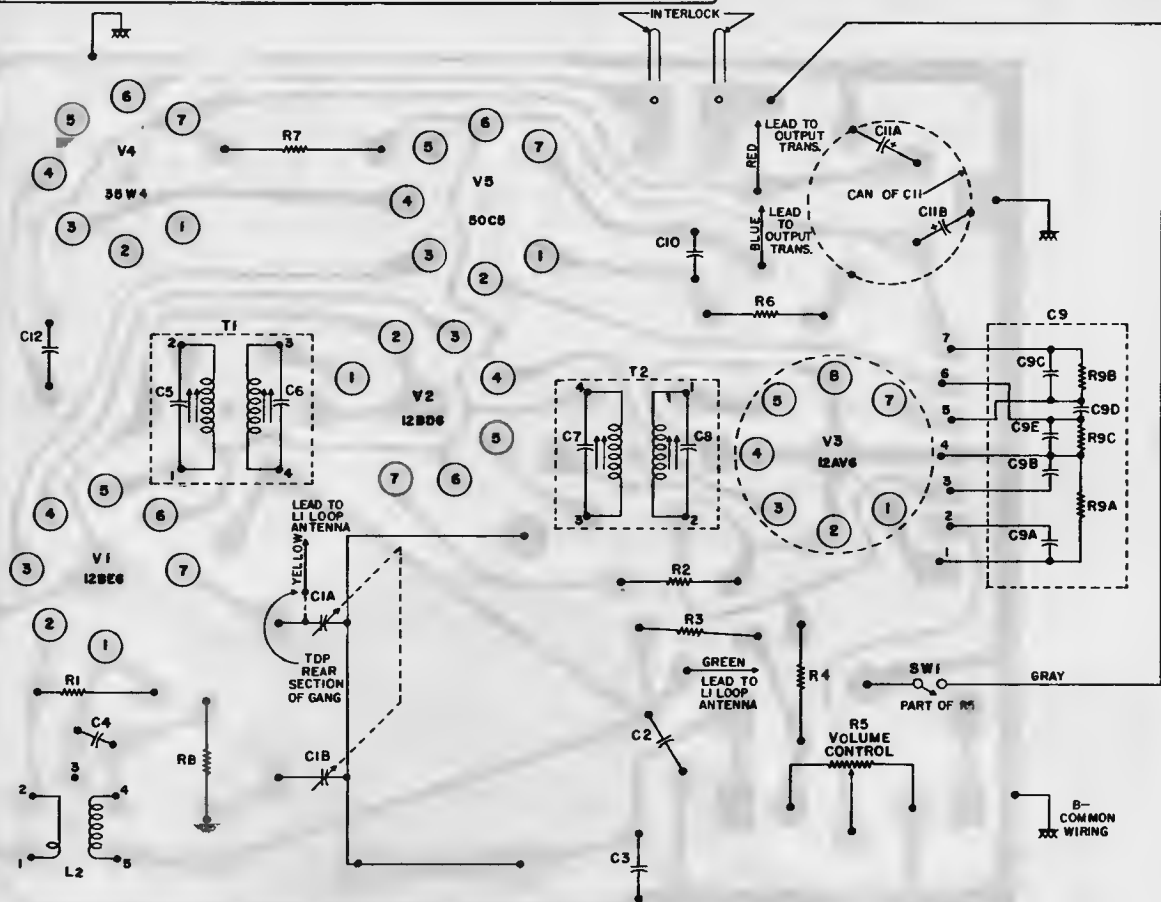
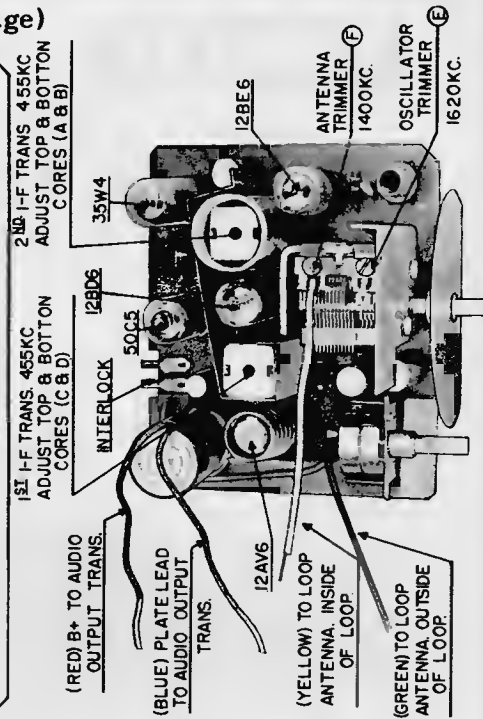

PRINTED CIRCUIT BOARD

As viewed from the PRINTED WIRING SIDE of board. The shaded areas represent the printed wiring. The black symbols and lettering represent components or connections on the opposite side of the board.

# CROSLEY

## CHASSIS 60T

Models: T-60GN, T-60RD  
T-60GY, T-60IY, T-60CL

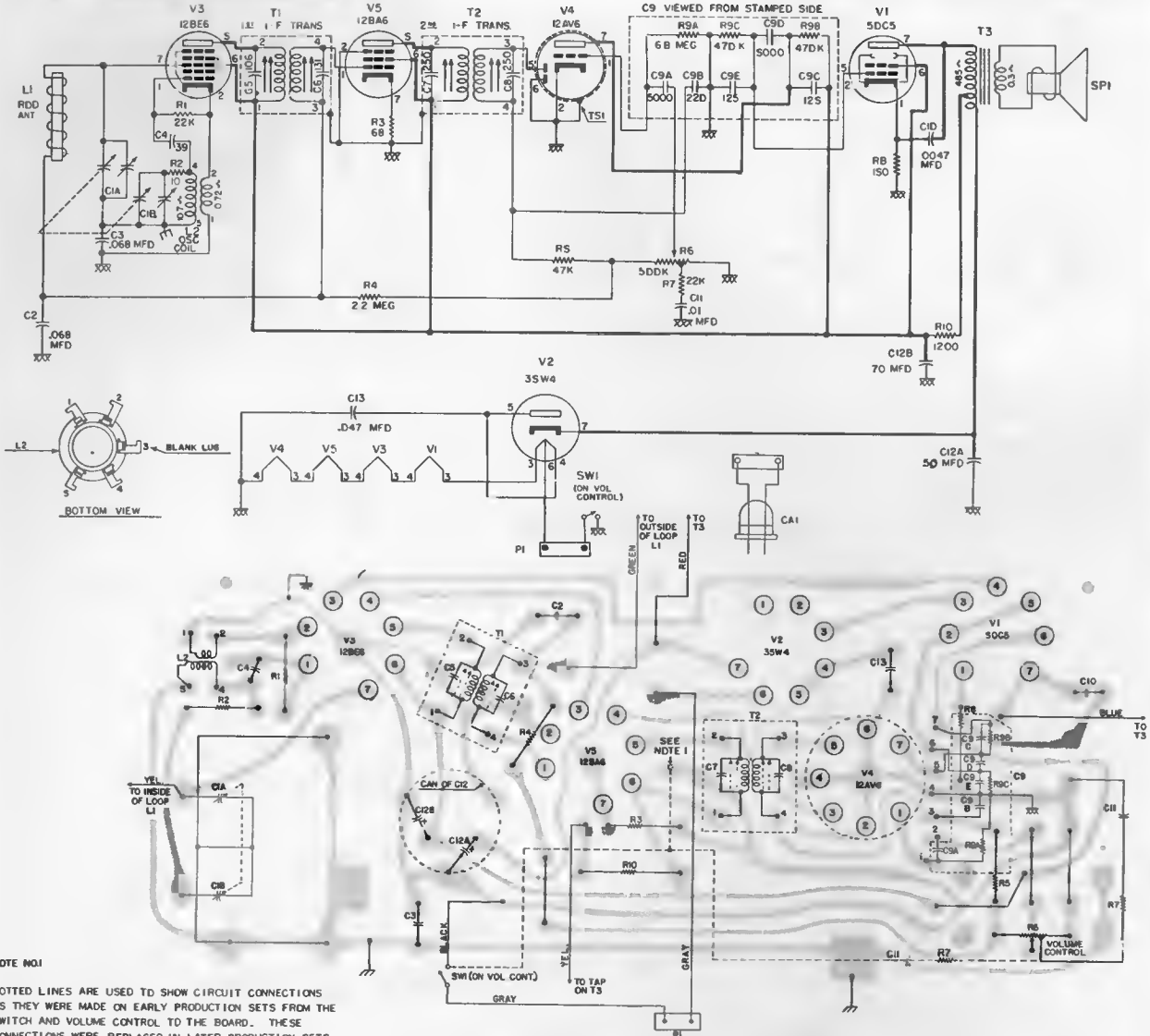

**NOTE #01**

DOTTED LINES ARE USED TO SHOW CIRCUIT CONNECTIONS AS THEY WERE MADE ON EARLY PRODUCTION SETS FROM THE SWITCH AND VOLUME CONTROL TO THE BOARD. THESE CONNECTIONS WERE REPLACED IN LATER PRODUCTION SETS BY THOSE SHOWN IN SOLID LINES.

FERRITE ROD ANTENNA

INTERLOCK

50C5

35W4

1<sup>ST</sup> I-F TRANS 455 KC  
ADJUST TOP & BOTTOM  
SLUGS (C&D)

12BA6

12BE6

ANT. TRIMMER (F)  
1400 KC  
OSC. TRIMMER (E)  
1620 KC

2<sup>ND</sup> I-F TRANS 455 KC  
ADJUST TOP & BOTTOM  
SLUGS (A&B)

12AV6

**NOTES**

- 1 K=1000 ALL TOLERANCES .20% UNLESS OTHERWISE NOTED
- 2 ALL RESISTANCE VALUES IN OHMS & CAPACITANCE VALUES IN MUF. UNLESS OTHERWISE NOTED
- 3 NUMBER ONE TERMINAL OF I-F TRANSFORMERS CODED WITH GREEN DOT, NUMBER PROGRESS CLOCKWISE
- 4 I-F 455 KC
- 5 & CHASSIS
- XXX COMMON WIRING

**DIAL STRING PLACEMENT**

TUNING GANG IN THE OPEN POSITION

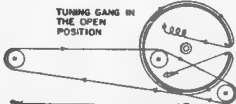

DIAL STRING 3/16" LOOP TO LOOP

DeWALD RADIO MFG. CORP.

MODEL K-544A

LIST OF REPLACEMENT PARTS

- 1st I.F. I-131-3
- 2nd I.F. I-131-4
- Osc. Coll 0-137
- Bar Loop Ant. L-138A
- Var. Cond. C-219
- Electrolytic Cond. E-221
- Volume Control V-311
- Cabinet C-445A
- Speaker 8-712
- Vol. Control Knob K-447
- Turning Knob K-448A
- Battery Cable BC-510
- Transistors.
- Converter CK760/2N112 OR 2N140
- IF CK760A/2N112A OR 2N139
- Audio Driver 2N132 OR 2N217
- Audio Output 2N138 OR 2N217
- Diode CK706A/1N295

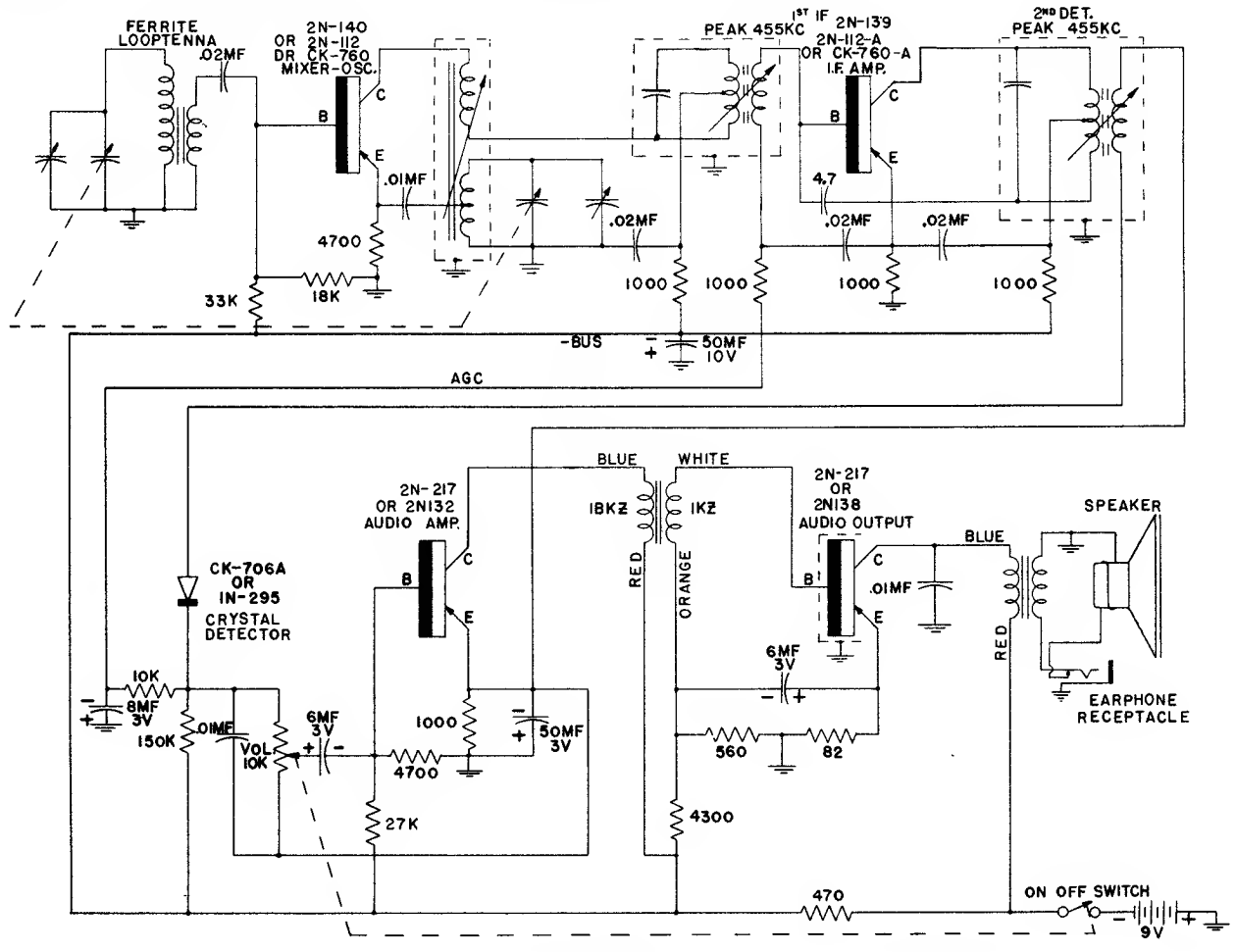
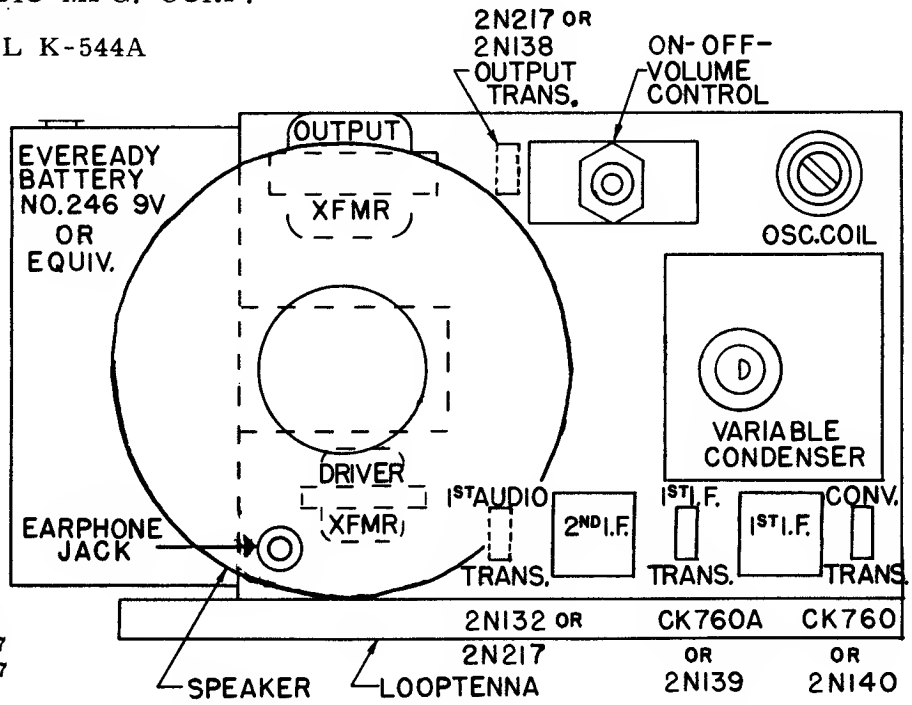

DeWALD RADIO Models K-701B and K-702B

LIST OF REPLACEMENT PARTS

Electrolytic Cond.	E-216-2	Vol. Control Knob	4228D-3	1st I.F.	I-131-1
Volume Control	V-310-1	Tuning Knob	4229D-6	2nd I.F.	I-131-1
Cabinet	C-444-D	Battery Cable	BC-509-3	3rd I.F.	I-131-2
Speaker	S-710-2	Electrolytic Cond.	E-215	Osc. Coil	O-133B-4
				Bar Loop Ant.	L-130E
				Var. Cond.	V-214-1

PEAK I.F. XFMRs. AT 455 KC.

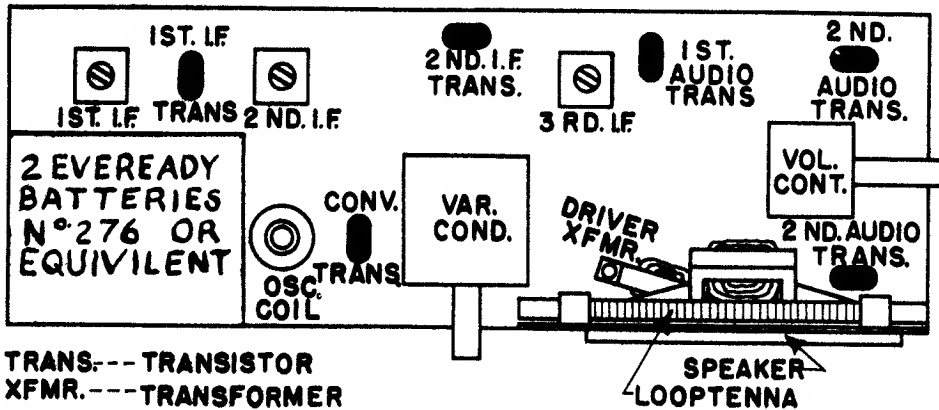

- Transistors  
 CK-760/2N112  
 CK-760A/2N112A  
 2N132  
 2N138  
 IN295

CK-760  
2N112  
CONV.

CK-760-A  
2N112-A  
1ST I.F.

CK-760-A  
2N112-A  
2ND I.F.

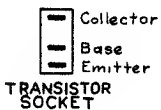
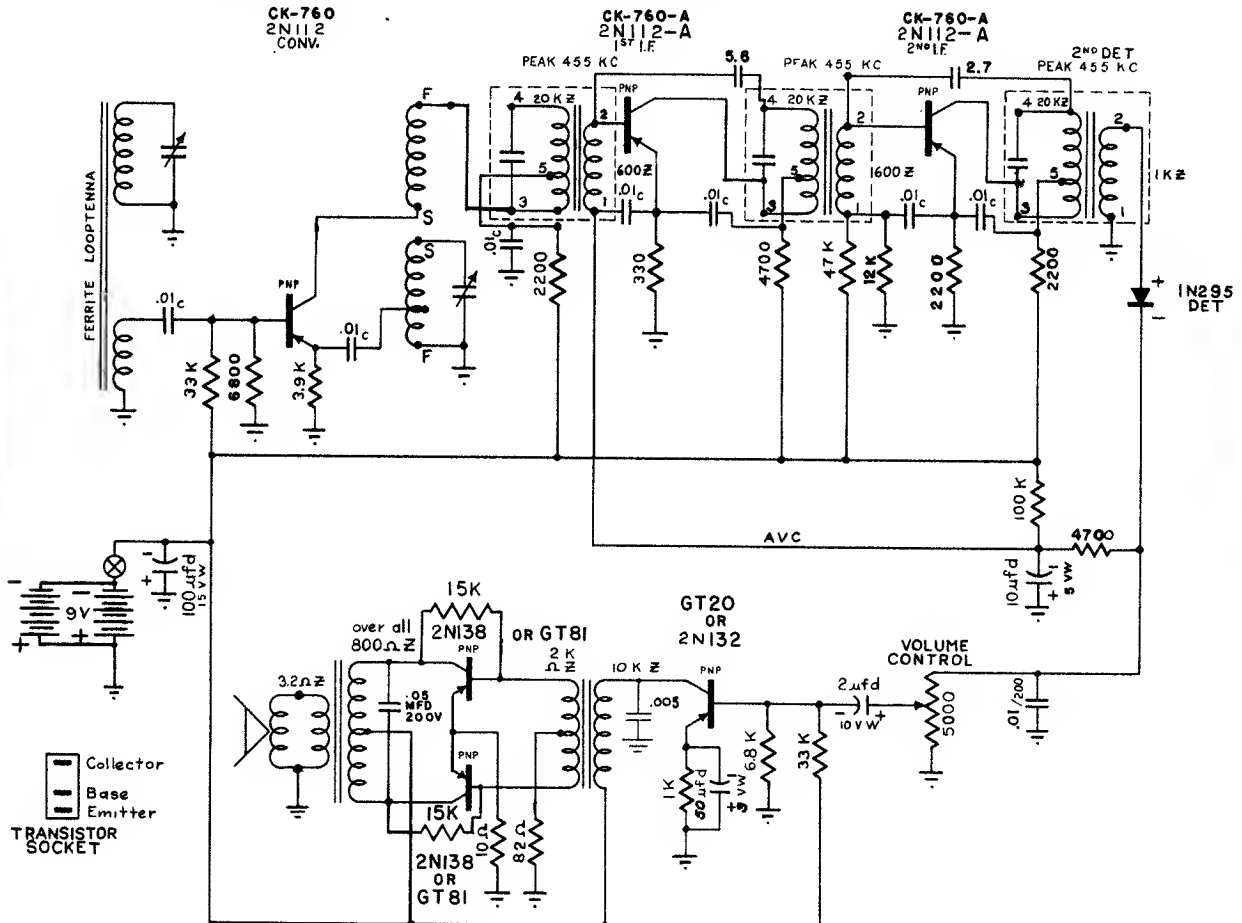

ALLEN B. DU MONT LABORATORIES, INC.

# DU MONT

## RA-354 AM PORTABLE RADIO

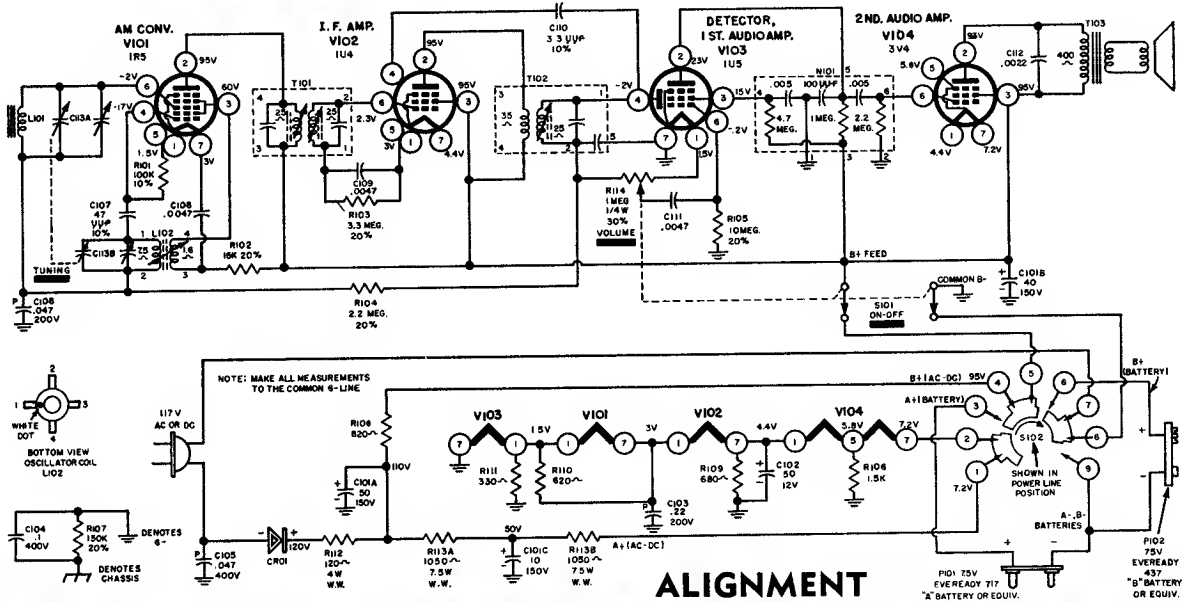

### ALIGNMENT

Step	Signal Generator		Tuning Capacitor Setting	Output Meter Connection	Adjust
	Frequency	Connect to			
1	455 KC 400 cps AM mod.	Loop, of several turns of wire placed near AM antenna	Maximum Capacity	AC meter across speaker voice call	I. F. Transformers T102 (top) and T101 (top and bottom) for maximum output indication.
2	1620 KC 400 cps AM Mod.	As above	Minimum Capacity	As above	Oscillator trimmer capacitor of C113B for maximum output indication.
3	1400 KC 400 cps AM Mod.	Remove wire loop from AM antenna. Radiate a signal into the set	Set tuning dial for strongest 1400 KC signal	As above	Antenna trimmer capacitor of C113A for maximum output indication. Re-check step 2.
4	600 KC 400 cps AM Mod.	As above	Set tuning dial to 600 KC	As above	Oscillator tracking coil L102 for maximum output. Note: L102 is preset at the factory and should not be adjusted unless necessary.

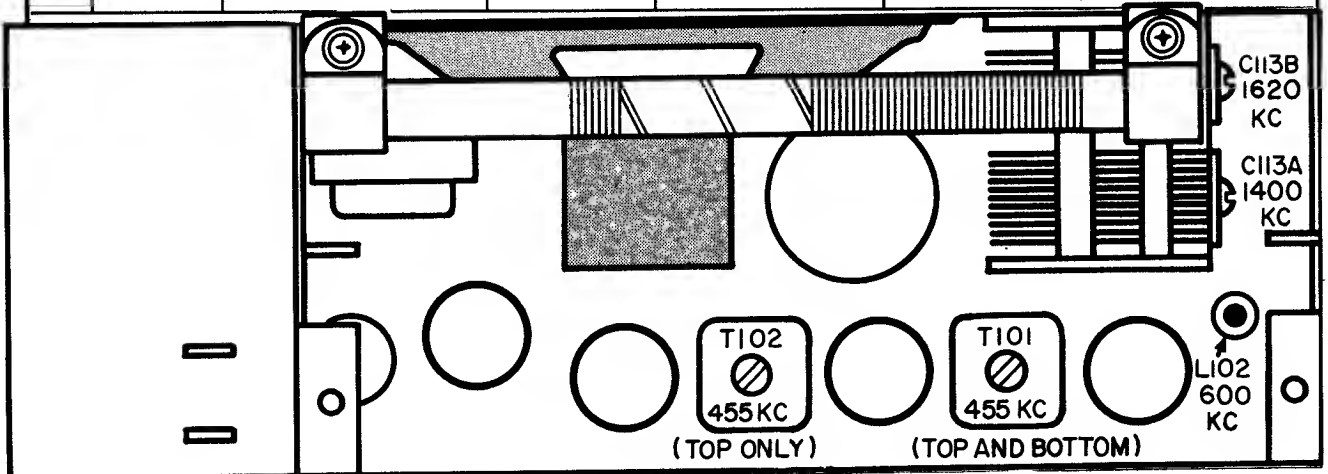

DuMont Models 1110, 1120, 1130, 1140, 1150

(See the next page adjacent at right for additional service material.)

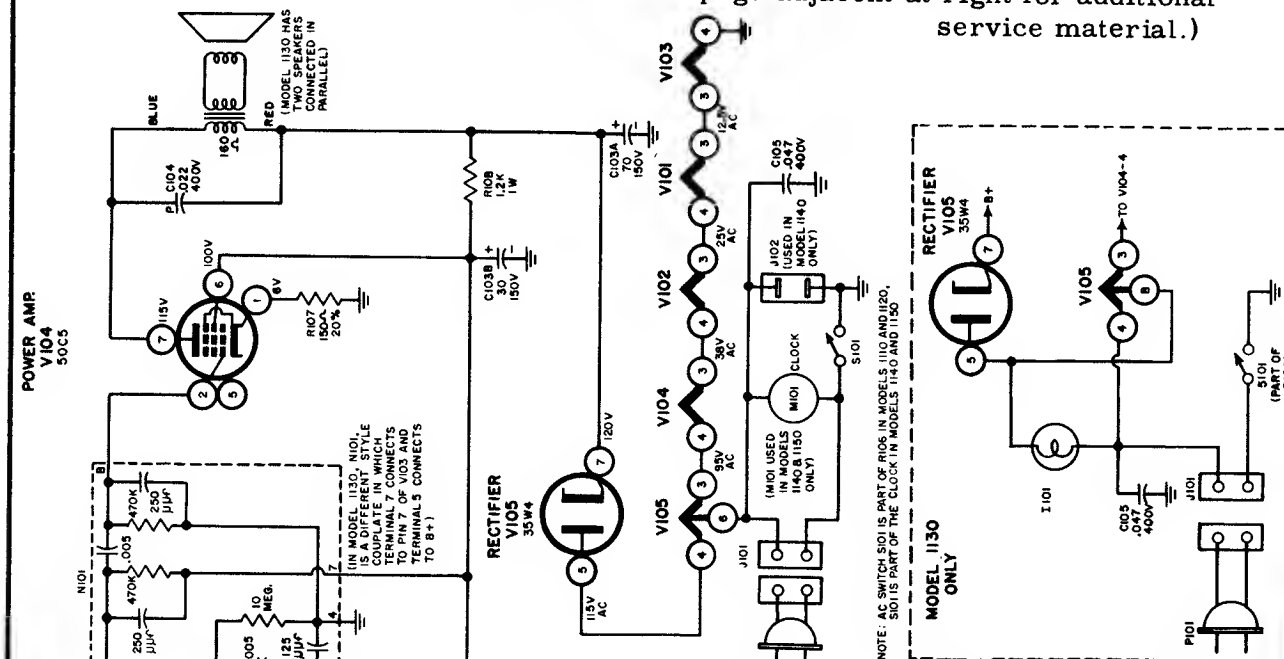

MODELS 1110, 1120, 1140 & 1150

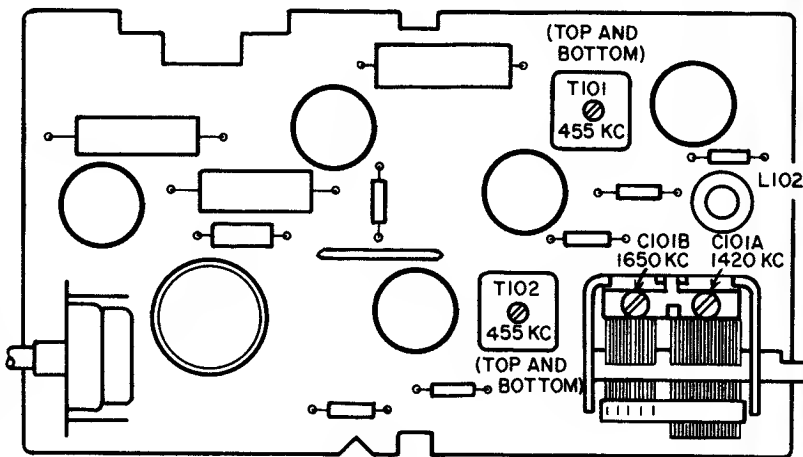

MODEL 1130

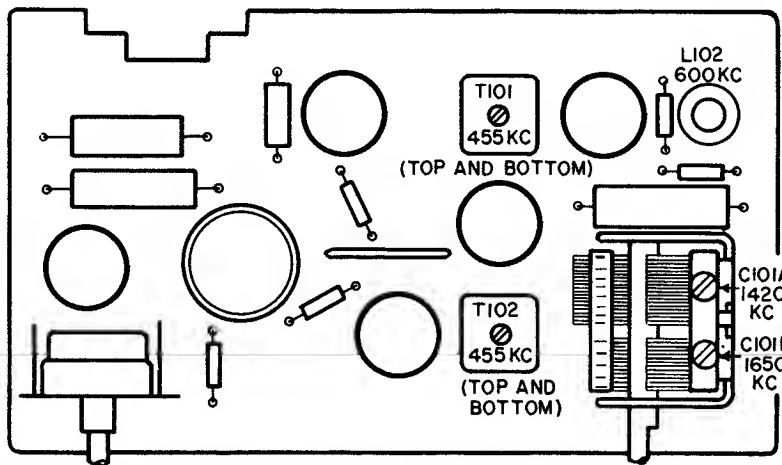



DuMont Models 1110, 1120, 1130, 1140, 1150. Continued from the preceding page.

**TUBE AND COMPONENT LOCATION — UNDERCHASSIS VOLTAGE POINTS**

MODELS 1110, 1120, 1130, 1140 & 1150

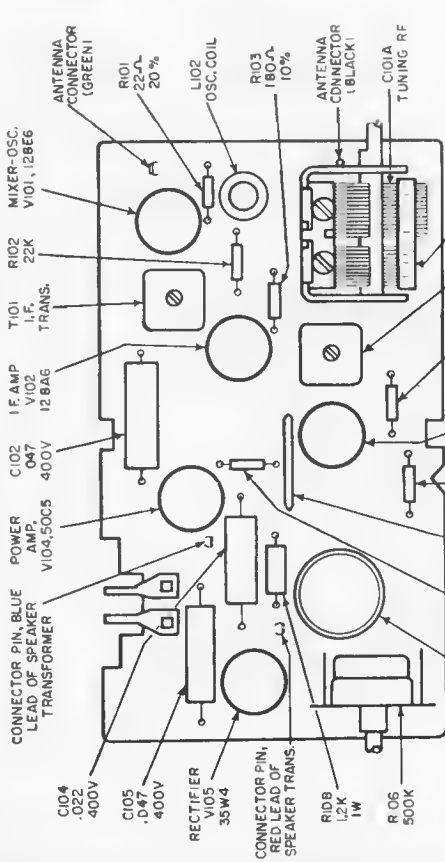

**MODEL 1130**

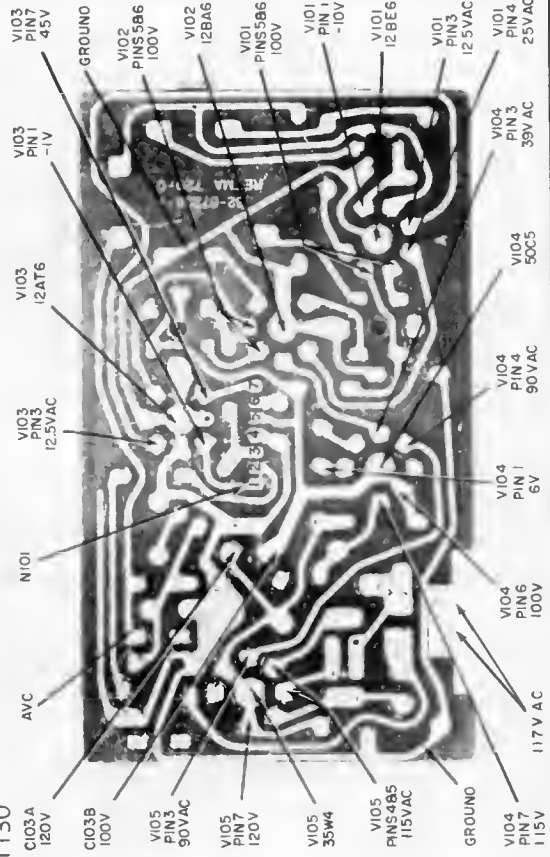
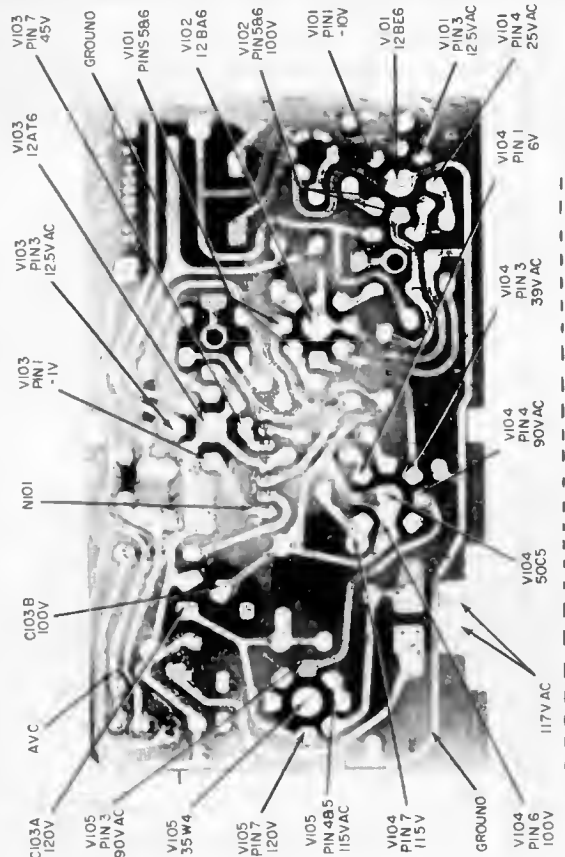
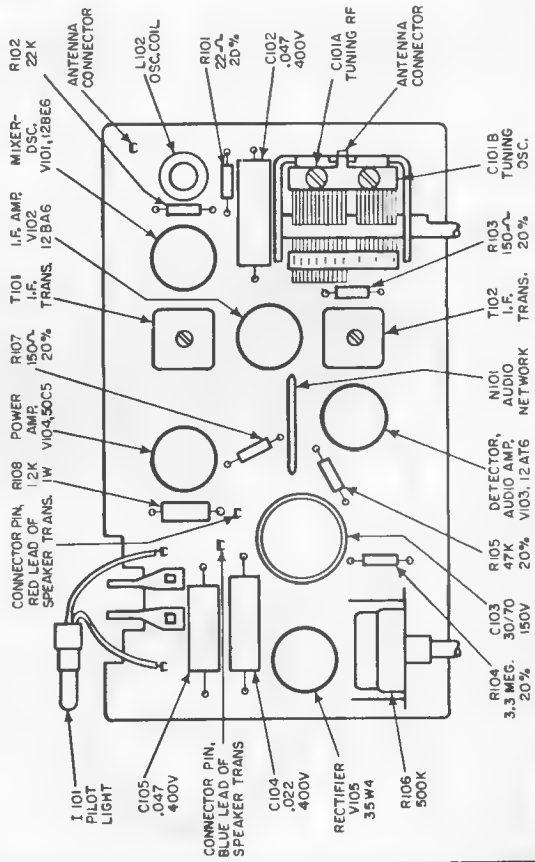

DuMont RA-378 Hi-Fi Amplifier and RA-379 AM Radio

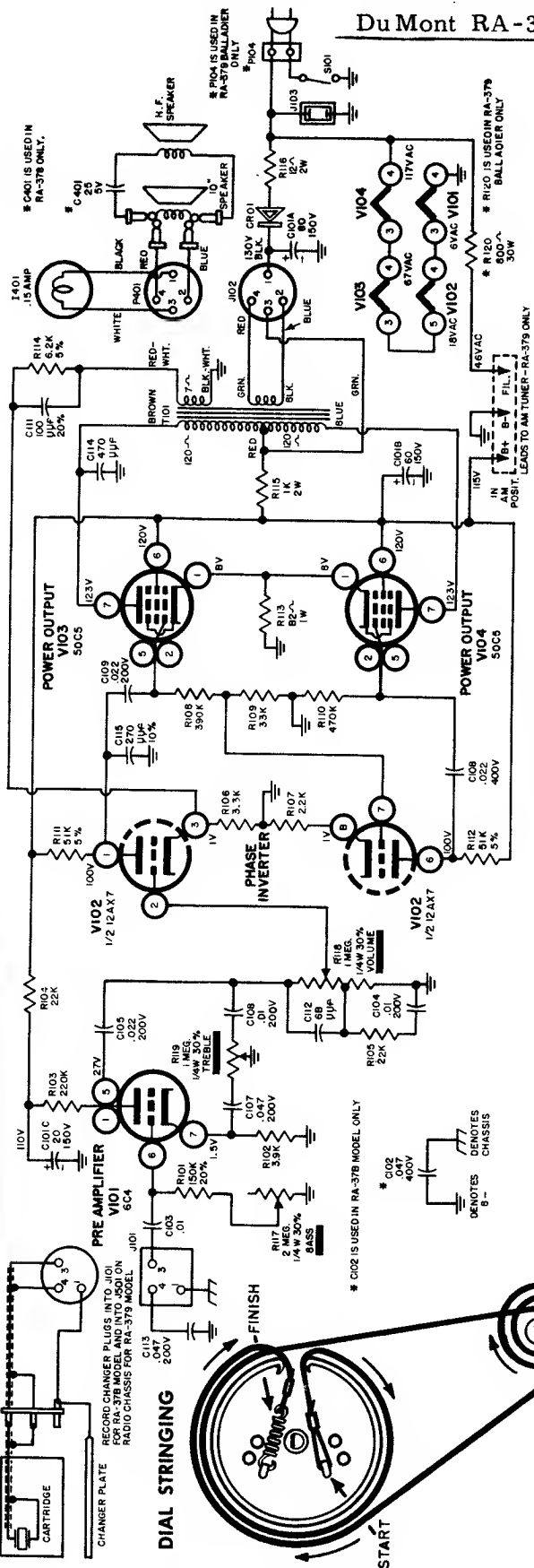

RA-378/379 AMPLIFIER SCHEMATIC

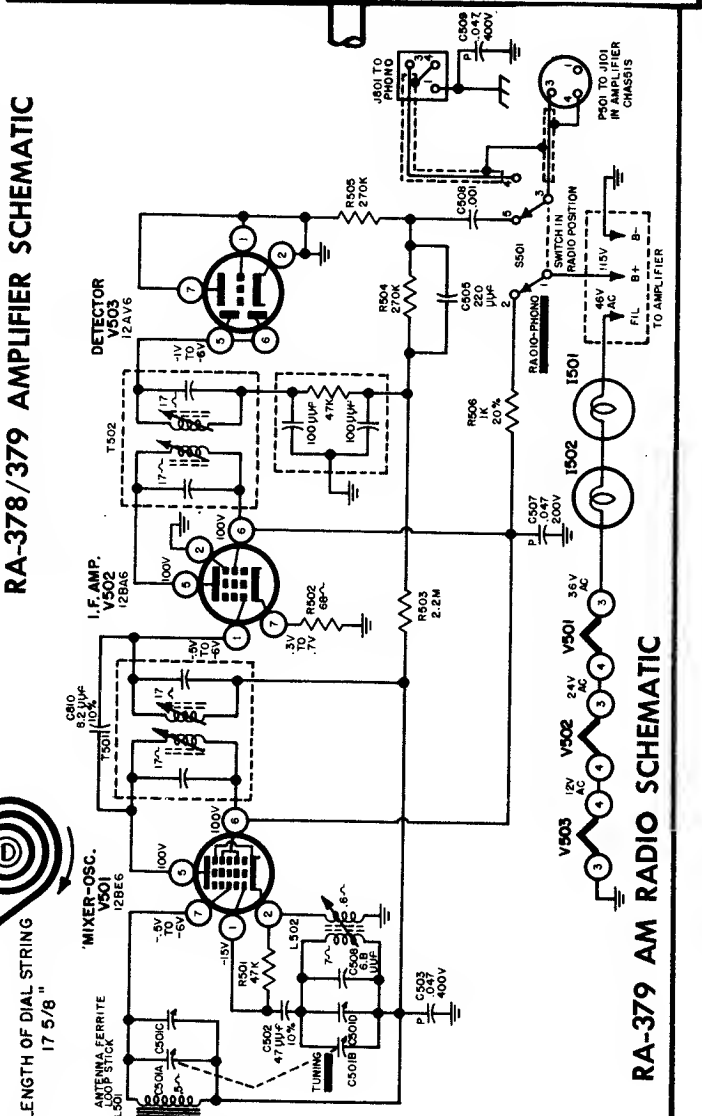
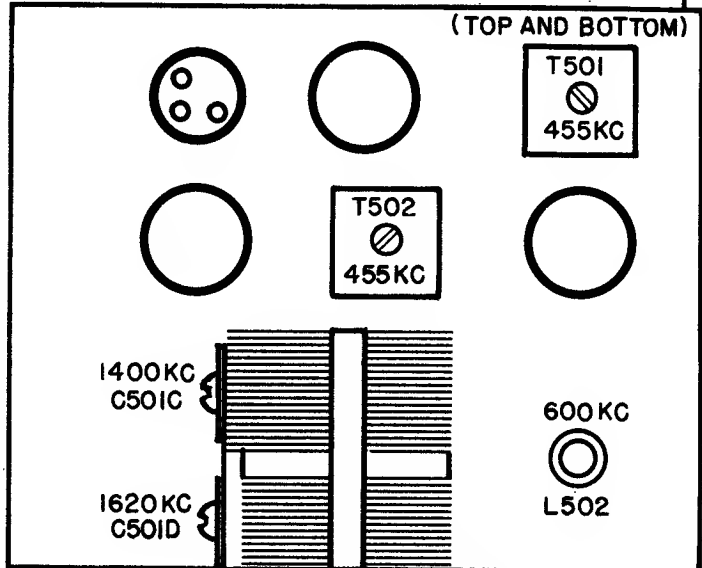

RA-379 AM RADIO SCHEMATIC

# Emerson Radio

MODEL 844  
CHASSIS 120309  
MODEL 847  
CHASSIS 120328

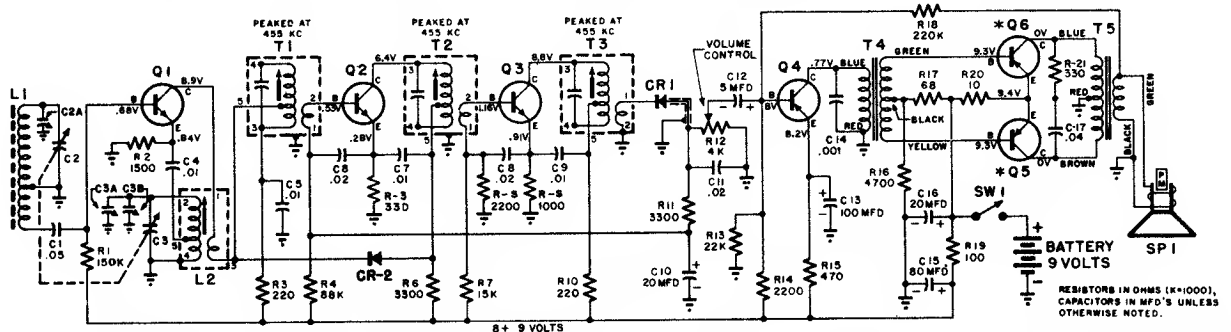

\* NOTE: IF ONE OF THESE TRANSISTORS Q-3 OR Q-6 BECOMES DEFECTIVE REPLACE BOTH OF THEM WITH A NEW MATCHED PAIR (PT. NO. 915014)

### RESISTANCE READINGS FOR CHASSIS 120309 120328

SYMBOL	TERMINAL B	TERMINAL C	TERMINAL E
Q1	165KΩ	3.3K*Ω	1500Ω
Q2	4KΩ	3800*Ω	330Ω
Q3	2KΩ	3.3K*Ω	1000Ω
Q4	4.2KΩ	500Ω	3.4KΩ
Q5	3K*Ω	22Ω	2.9K*Ω
Q6	3K*Ω	18	2.9*KΩ

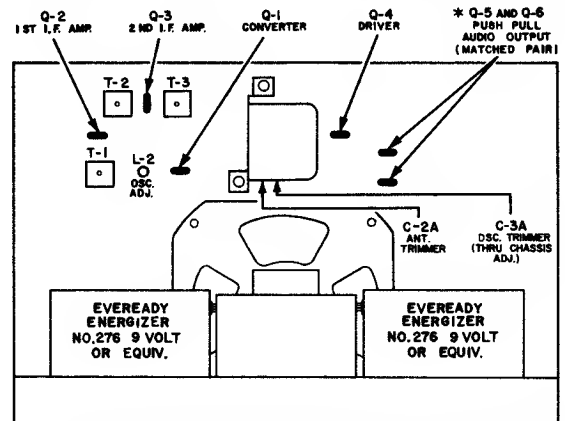

\* NOTE: IF ONE OF THESE TRANSISTORS Q-5 OR Q-6 BECOMES DEFECTIVE REPLACE BOTH OF THEM WITH A NEW MATCHED PAIR (PT. NO. 915014)

### CONDITIONS FOR VOLTAGE AND RESISTANCE READINGS

1. Voltages indicated are positive d.c., resistance is ohms.
2. Measurements made with voltohmmyst or equivalent.
3. All measurements taken between points and chassis, unless otherwise indicated.
4. Before taking resistance measurements, turn on-off switch to the "off" position (or disconnect batteries). Then remove transistors.
5. Volume control of maximum, no signal applied for voltage measurements.
6. Nominal tolerance in component values makes possible a variation of ± 15% in readings.
7. K is Kilohms, MEG is megohms.

Figure 1 - TRANSISTOR AND BATTERY LOCATION DIAGRAM

### ALIGNMENT INSTRUCTIONS

Volume control should be at maximum; output of signal generator should be no higher than necessary to obtain on output reading with a 30% audio modulated R.F. Use an insulated alignment screwdriver for adjusting.

	DUMMY ANTENNA	SIGNAL GENERATOR COUPLING	SIGNAL GENERATOR FREQUENCY	RADIO DIAL SETTING	OUTPUT METER	ADJUST	REMARKS
1	.1 mfd.	High side to junction of L-1 & C-2. Low side to chassis.	455 KC.	Tuning condenser fully open.	Across voice coil.	T2, T3 and T1	Adjust for maximum output starting with T3.
2		Use a loop set perpendicular and about 20" from center of bar loop ant. in set.	1650 KC.	Tuning condenser fully open.	Across voice coil.	C-3A (osc. trimmer)	Fashion loop of several turns of wire and radiate signal into bar loop of receiver. Adjust for maximum output. See note below.
3		"	1400 KC.	Tune for maximum output.	Across voice coil.	C-2A (Ant. trimmer)	Adjust for maximum output.
4		"	600 KC.	Tuning condenser set for 600 KC.	Across voice coil.	Osc. slug in L-2	Rock the variable cond. each side of 600 KC while adj. osc. slug for maximum response.
5		"	1650 KC.	Tuning condenser fully open.	"	C-3A Osc. trimmer	If readjustment is necessary repeat steps 2 to 4 until no further improvement is noted.

NOTE: C-3A is the oscillator trimmer capacitor, physically located on the bottom side of the tuning capacitor when the chassis is mounted in its case. Both C-3A and C-2A can be reached (see Fig. 1.) C-3B is the alternate oscillator trimmer capacitor and is factory adjusted for minimum trimmer capacity requirements.

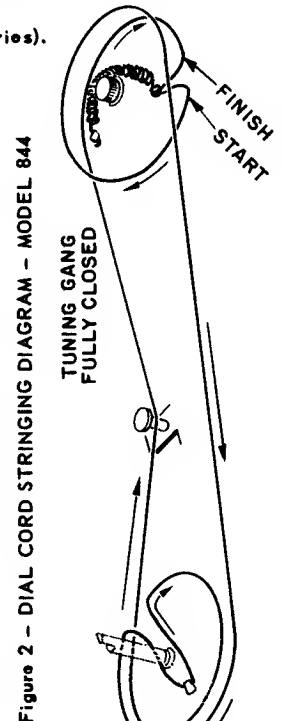
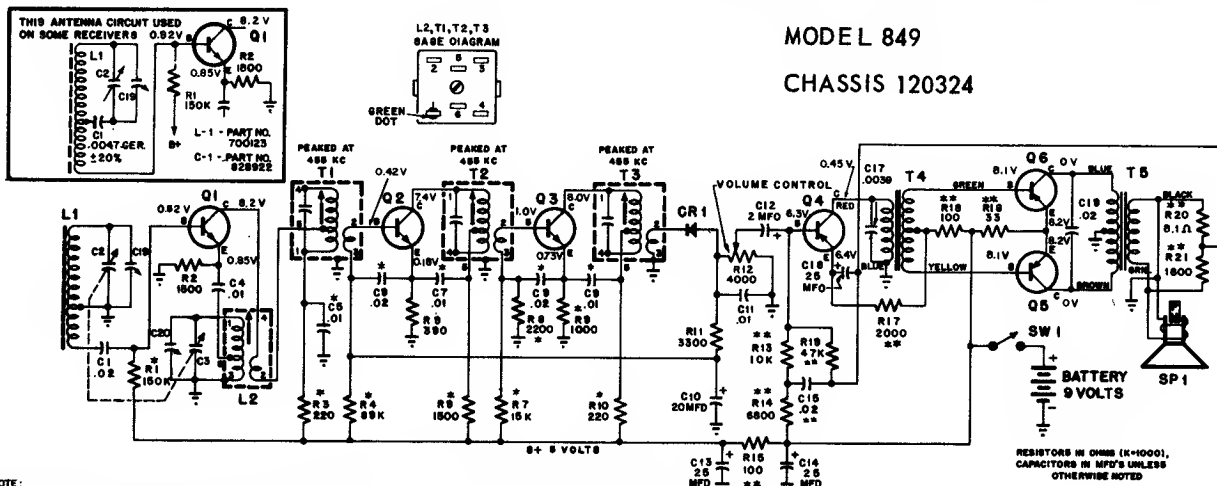

Figure 2 - DIAL CORD STRINGING DIAGRAM - MODEL 844

# EMERSON RADIO & PHONOGRAPH CORPORATION

MODEL 849

CHASSIS 120324



NOTE:  
\* COMPONENT MOUNTED ON ETCHED WIRED BOARD # 830181  
\*\* COMPONENT MOUNTED ON ETCHED WIRED BOARD # 830179

NOTES:  
IF ONE OF THESE TRANSISTORS (Q5 OR Q6) BECOMES DEFECTIVE REPLACE BOTH OF THEM WITH A NEW MATCHED PAIR.

RESISTORS IN OHMS (K=1000), CAPACITORS IN MFD'S UNLESS OTHERWISE NOTED

## RESISTANCE READINGS

(TURN SET 'OFF' THEN REMOVE ALL TRANSISTORS BEFORE TAKING RESISTANCE READINGS)

SYMBOL	TERMINAL B	TERMINAL C	TERMINAL E
Q-1	170K	*11K	1500
Q-2	4.5K	*13K	330
Q-3	2.2K	*11K	1K
Q-4	18K	600	*13K
Q-5	*12K	40	11K
Q-6	*12K	40	11K

RESISTANCE READINGS SHOWN ABOVE IN OHMS UNLESS OTHERWISE SPECIFIED.

\*Wait approx. 1 minute till meter settles.

## ENERGIZER - EVEREADY \* 226 OR EQUIV.

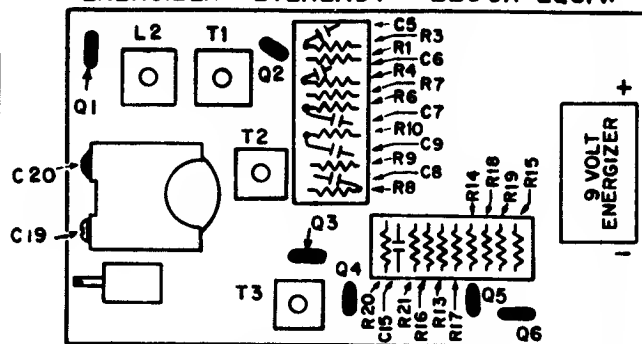

ALIGNMENT, TRANSISTOR AND BATTERY LOCATION DIAGRAM

## ALIGNMENT INSTRUCTIONS

Volume control should be at maximum; output of signal generator should be no higher than necessary to obtain an output reading with a 30% audio modulated R.F. Use an insulated alignment screwdriver for adjusting.

	DUMMY ANTENNA	SIGNAL GENERATOR COUPLING	SIGNAL GENERATOR FREQUENCY	RADIO DIAL SETTING	OUTPUT METER	ADJUST	REMARKS
1	.1 mfd.	High side to junction of L-1 & C-2. Low side to chassis.	455 KC.	Tuning condenser fully open.	Across voice coil.	T2, T3 and T1	Adjust for maximum output starting with T3.
2		Use a loop set perpendicular and about 20" from center of bar loop ant. in set.	1640 KC.	Tuning condenser fully open.	Across voice coil.	C-20 (osc. trimmer)	Fashion loop of several turns of wire and radiates signal into bar loop of receiver. Adjust for maximum output.
3		"	1400 KC.	Tune for maximum output.	Across voice coil.	C-19 (Ant. trimmer)	Adjust for maximum output.
4		"	600 KC.	Tuning condenser set for 600 KC.	Across voice coil.	Osc. slug in L-2	Rock the variable cond. each side of 600 KC while adj. osc. slug for maximum response.
5		"	1640 KC.	Tuning condenser fully open.	"	C-20 Osc. trimmer	If readjustment is necessary repeat steps 2 to 4 until no further improvement is noted.

# VOLUME R-17, MOST-OFTEN-NEEDED 1957 RADIO SERVICING INFORMATION

## EMERSON RADIO Model 855, Chassis 120314

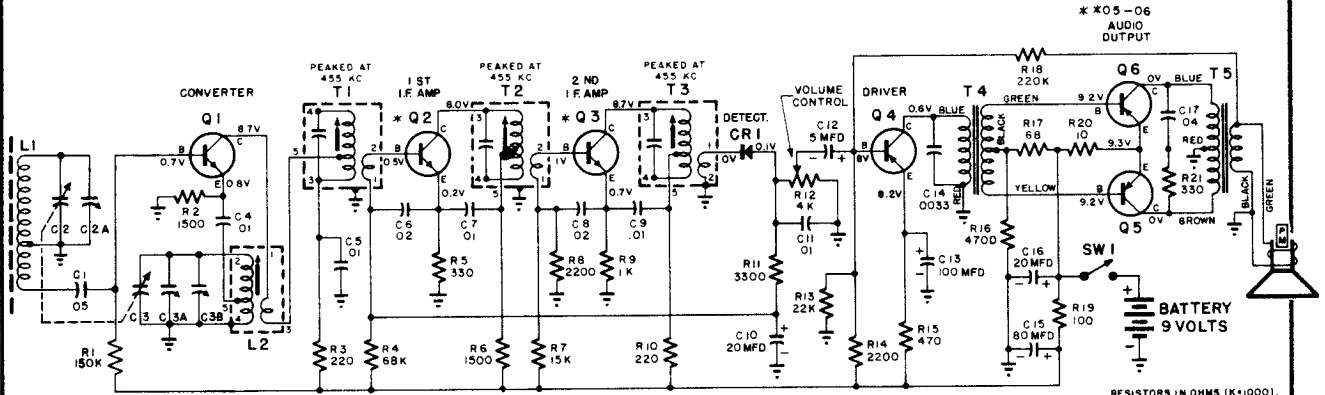

\* EMERSON PT NO B15010 CALLED OFF FOR Q2 AND Q3 CAN BE EITHER TWO (2) - 2N146 OR A 2N145 AND A 2N147 TRANSISTOR FOR REPLACEMENT PURPOSES HOWEVER, OUR PT NO B15010 WILL BE A 2N146 TRANSISTOR

NOTES  
\* \* IF ONE OF THESE TRANSISTORS Q5 OR Q6 BECOMES DEFECTIVE REPLACE BOTH OF THEM WITH A NEW MATCHED PAIR.

RESISTORS IN OHMS (K=1000). CAPACITORS IN MFD'S UNLESS OTHERWISE NOTED

### RESISTANCE READINGS

TURN SET "OFF" THEN REMOVE ALL TRANSISTORS BEFORE TAKING RESISTANCE READINGS

SYMBOL	TERMINAL B	TERMINAL C	TERMINAL E
Q-1	150K	3.4K	1500
Q-2	4K	4BK	330
Q-3	1.9K	1K	3.4K
Q-4	4.5K	500	3.4K
Q-5	3.2K	19	3.2K
Q-6	3.2K	21	3.2K

RESISTANCE READINGS SHOWN ABOVE IN OHMS UNLESS OTHERWISE SPECIFIED

Voltages indicated are positive d.c., resistance is ohms. Measurements made with vohmmyst or equivalent. All measurements taken between points and chassis,

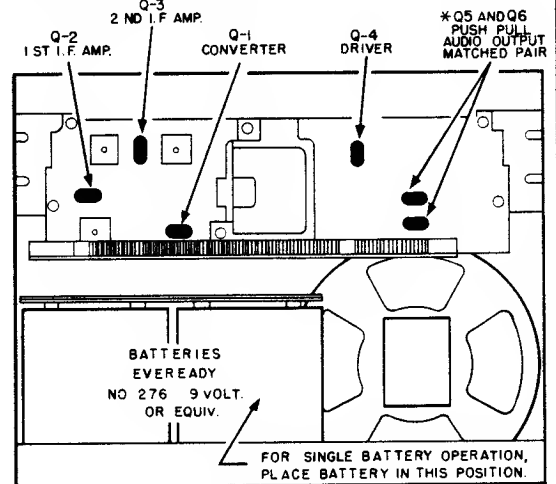

\* NOTE IF ONE OF THESE TRANSISTORS Q5 OR Q6 BECOMES DEFECTIVE REPLACE BOTH OF THEM WITH A NEW MATCHED PAIR

### ALIGNMENT INSTRUCTIONS

Volume control should be at maximum; output of signal generator should be no higher than necessary to obtain an output reading with a 30% audio modulated R.F. Use an insulated alignment screwdriver for adjusting.

	DUMMY ANTENNA	SIGNAL GENERATOR COUPLING	SIGNAL GENERATOR FREQUENCY	RADIO DIAL SETTING	OUTPUT METER	ADJUST	REMARKS
1	.1 mfd.	High side to junction of L-1 & C-2. Low side to chassis.	455 KC.	Tuning condenser fully open.	Across voice coil.	T2, T3 and T1	Adjust for maximum output starting with T3.
2		Use a loop set perpendicular and about 20" from center of bar loop ant. in set.	1650 KC.	Tuning condenser fully open.	Across voice coil	C-3A (osc. trimmer) See note below	Fashion loop of several turns of wire and radiate signal into bar loop of receiver. Adjust for maximum output.
3		"	1400 KC.	Tune for maximum output.	Across voice coil.	C-2A (Ant. trimmer)	Adjust for maximum output.
4		"	600 KC.	Tuning condenser set for 600 KC.	Across voice coil.	Osc. slug in L-2	Rock the variable cond. each side of 600 KC while adj. osc. slug for maximum response.
5		"	1650 KC.	Tuning condenser fully open.	"	C-3A Osc. trimmer	If readjustment is necessary repeat steps 2 to 4 until no further improvement is noted.

NOTE: C-3A is the oscillator trimmer capacitor, physically located on the bottom side of the tuning capacitor when the chassis is mounted in its case. Both C-3A and C-2A can be reached through cutouts in the antenna mounting board. C-3B is the alternate oscillator trimmer capacitor and is factory adjusted for minimum trimmer capacity requirements.

# EMERSON RADIO & PHONOGRAPH CORPORATION

(Service material continued on the next page adjacent at right.)

MODEL 851B  
CHASSIS 120327B  
MODEL 852B  
CHASSIS 120334B  
MODEL 853B  
CHASSIS 120335B

RESISTANCE READINGS

SYMBOL	TUBE	PIN-1	PIN-2	PIN-3	PIN-4	PIN-5	PIN-6	PIN-7
V-1	12BE6	22K	10 Ω	32 Ω	22 Ω	700K	700K	3 M
V-2	12BA6	3 M	0	32 Ω	700K	700K	700K	120 Ω
V-3	12AT6 OR 12AV6	8.2 M	0	0	22 Ω	500K	0	700K
V-4	50C5	150 Ω	470K	42 Ω	93 Ω	500K	700K	700K
V-5	35W4	N.C.	N.C.	85 Ω	120 Ω	135 Ω	115 Ω	700K

† WAIT FOR METER TO SETTLE  
‡ 15 OHMS CHASSIS 120327-B

## CONDITIONS FOR VOLTAGE AND RESISTANCE READINGS

1. Voltages indicated are positive d.c., resistances in ohms, unless otherwise indicated.
2. Measurements made with voltohmmyst or equivalent.
3. All measurements taken from pin to B neutral unless otherwise indicated.
4. Voltage measurements taken with:
  - a) Line voltage maintained at 117 volts a.c.
  - b) Volume control set for maximum volume.
  - c) Variable condenser fully closed and no signal applied.
5. Resistance measurements taken with:
  - a) Power line cord disconnected from outlet.
  - b) Volume control set for maximum volume.
  - c) Variable condenser fully closed and no signal applied.
6. Nominal tolerance on component values makes possible a variations of ±15% in voltage and resistance readings.
7. N.C. denotes no connection, K is kilohms, Meg. is megohms. Resistances marked \* are measured to Pin 7 of Rectifier 35W4(B+).

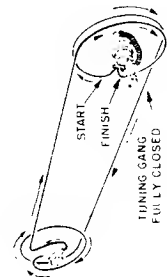

DIAL CORD STRINGING

NOTES:  
CORRECT SPEAKER PHASING MUST BE OBSERVED.  
\*USED ON CHASSIS NOS. 120334-B AND 120335-B.  
\*\*USED ONLY ON CHASSIS NO. 120327-B.  
\*\*\*USED ONLY ON CHASSIS NO. 120335-B.

CAPACITORS LESS THAN ONE IN MFD. CAPACITORS MORE THAN ONE ARE IN MMFD. UNLESS OTHERWISE SPECIFIED. RESISTORS ARE IN OHMS (K=1000 OHMS) AND 1/2 WATT UNLESS OTHERWISE NOTED

MODULE, TOP VIEW

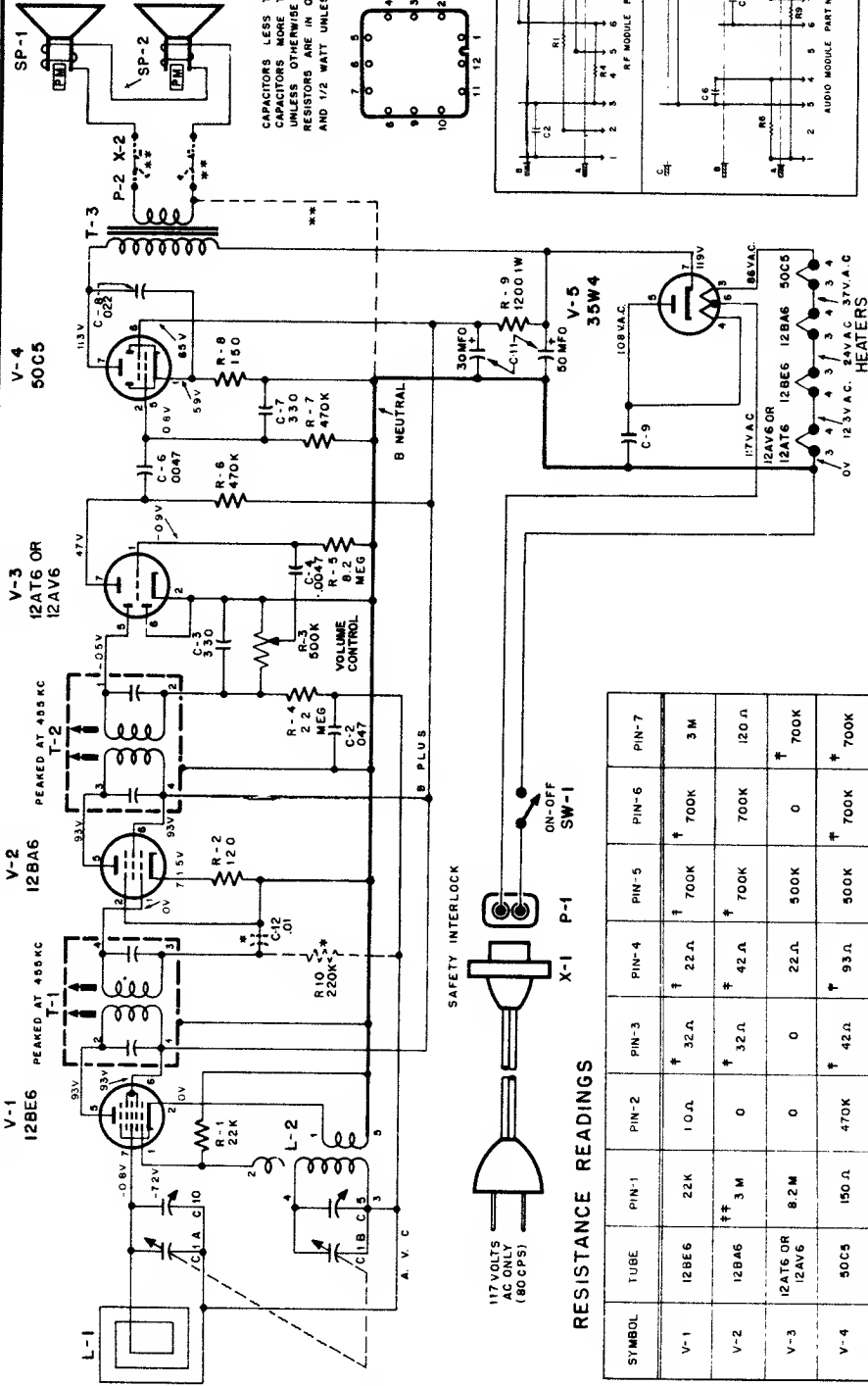
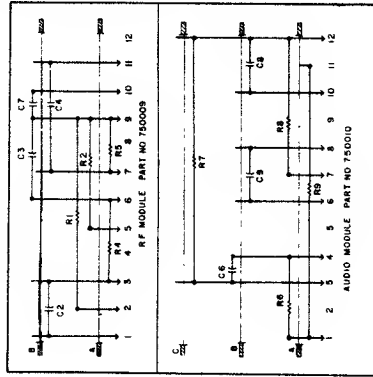

RESISTANCE READINGS

SYMBOL	TUBE	PIN-1	PIN-2	PIN-3	PIN-4	PIN-5	PIN-6	PIN-7
V-1	12BE6	22K	10 Ω	32 Ω	22 Ω	700K	700K	3 M
V-2	12BA6	3 M	0	32 Ω	700K	700K	700K	120 Ω
V-3	12AT6 OR 12AV6	8.2 M	0	0	22 Ω	500K	0	700K
V-4	50C5	150 Ω	470K	42 Ω	93 Ω	500K	700K	700K
V-5	35W4	N.C.	N.C.	85 Ω	120 Ω	135 Ω	115 Ω	700K

† WAIT FOR METER TO SETTLE  
‡ 15 OHMS CHASSIS 120327-B

# EMERSON RADIO

Model 851B, Chassis 120327B

Model 852B, Chassis 120334B

Model 853B, Chassis 120335B

(Continued from preceding page)

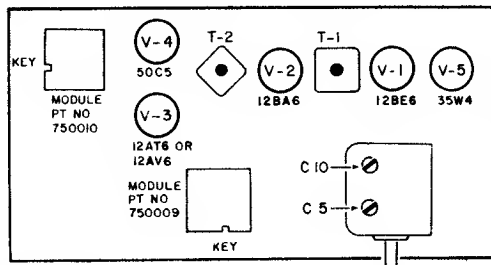

## ALIGNMENT INSTRUCTIONS

1. Use isolation transformer if available. If not, connect a .25 mfd. condenser in series with low side of signal generator and B neutral. (Low side of volume control.)
2. Volume control should be at maximum position. Output of signal generator should be no higher than necessary to obtain an output reading. Use an insulated screwdriver for adjusting.

STEP	DUMMY ANTENNA	SIGNAL GENERATOR COUPLING	SIGNAL GENERATOR FREQUENCY	RADIO DIAL SETTING	OUTPUT METER	ADJUST	REMARKS
1	.005 mfd.	High side to grid (pin 7) of V1 (12BE6). Low side to B-neutral. (See Alignment Note)	455 KC	Variable condenser fully open.	Across voice coil.	T2, T1	Adjust for maximum output.
2		Form loop of several turns and radiote signal into receiver.	1620 KC	"	Across voice coil.	Trimmer C-1B (Disc.)	Adjust for maximum output.
3		"	1400 KC	Tune for maximum output.	Across voice coil.	Trimmer C-1A (Ant.)	Adjust for maximum output.

## SERVICING MODULIZED RADIO CHASSIS

### 1. General Information

The same care should be exercised in repairing a modulated etched wiring radio chassis as is used in regular etched circuit board repair (low wattage iron, stiff brush, etc.). Past experience has indicated that the majority of radio failures are due to tubes and components which are not included within a module (electrolytic, oscillator coil, volume control, etc.), therefore, the type of service required on modulated chassis will generally be the same as for conventional chassis.

Since most of the R & C components in the R.F. and I.F. sections are in one module and the audio R & C components in the other, it would only be necessary to isolate the trouble to one of the modules rather than to a specific component. This should reduce troubleshooting time on the more difficult repair jobs, especially those which are of an intermittent nature.

If a particular trouble could be isolated to a defective component as easily as to a defective module, or if a replacement module were not immediately available, it would be desirable to repair rather than replace the module. Information on the replacement and repair of a module is given below.

### 2. Replacement of a Module

- a-Remove defective module by dipping underside (dip soldered side) in a small solder pot (which is now commercially available) or apply a solder iron or gun with a square shaped tip to all of the risers at the same time.
- b-While the heat is being applied to all of the risers at the same time by one of the above methods, pull the defective module away from the etched circuit board. (Note the location of the module positioning notch with respect to the etched board).
- c-Place a new module in the etched board making certain to position it as the original and individually solder each riser in place or dip in a solder pot.

Note: To reduce the possibility of interchanging modules during repair or orientating the module incorrectly, several unused riser wires are clipped below deck "A" as can be noted on the module schematic. The combination of clipped riser wires are different between the two modules. Since there are no holes in the etched circuit board to correspond to these clipped risers an exact replacement module can only be inserted the correct way.

### 3. Repair of Modules

The module diagrams shown on the schematic provide enough information to determine whether or not it would be practical to repair the module for a particular defect and if so how to proceed. These diagrams not only show the risers to which a component is connected, but also to which deck (A, B, C) it is physically mounted. This type of information is necessary to properly isolate a defective module component by cutting a riser wire and to show what other components are removed from the circuit at the same time. If it is practical to repair the module, then all modular components removed from the circuit (connected above the point where the riser is cut) must be replaced by conventional components soldered directly to the dip soldered side of the etched circuit board.

- a-Determine defective component by general troubleshooting procedures.
- b-Refer to proper module diagram on schematic and decide whether or not this component could be isolated (by cutting riser wire or wires) without disconnecting too many other components from the circuit.
- c-If repair is practical, cut required riser wire or wires and connect replacement component or components to dip-soldered side of etched board (across proper riser wires) rather than to module itself.

Note: A diagonal cutters should never be used to cut a riser wire between decks since permanent damage could result. The pinching action of a diagonal cutter could crack one or more of the module decks. A very fine toothed saw blade or a small hand powered tool with a 1/32" abrasive disk should be used for this purpose.

EMERSON RADIO Model 858B, Chassis 120336B

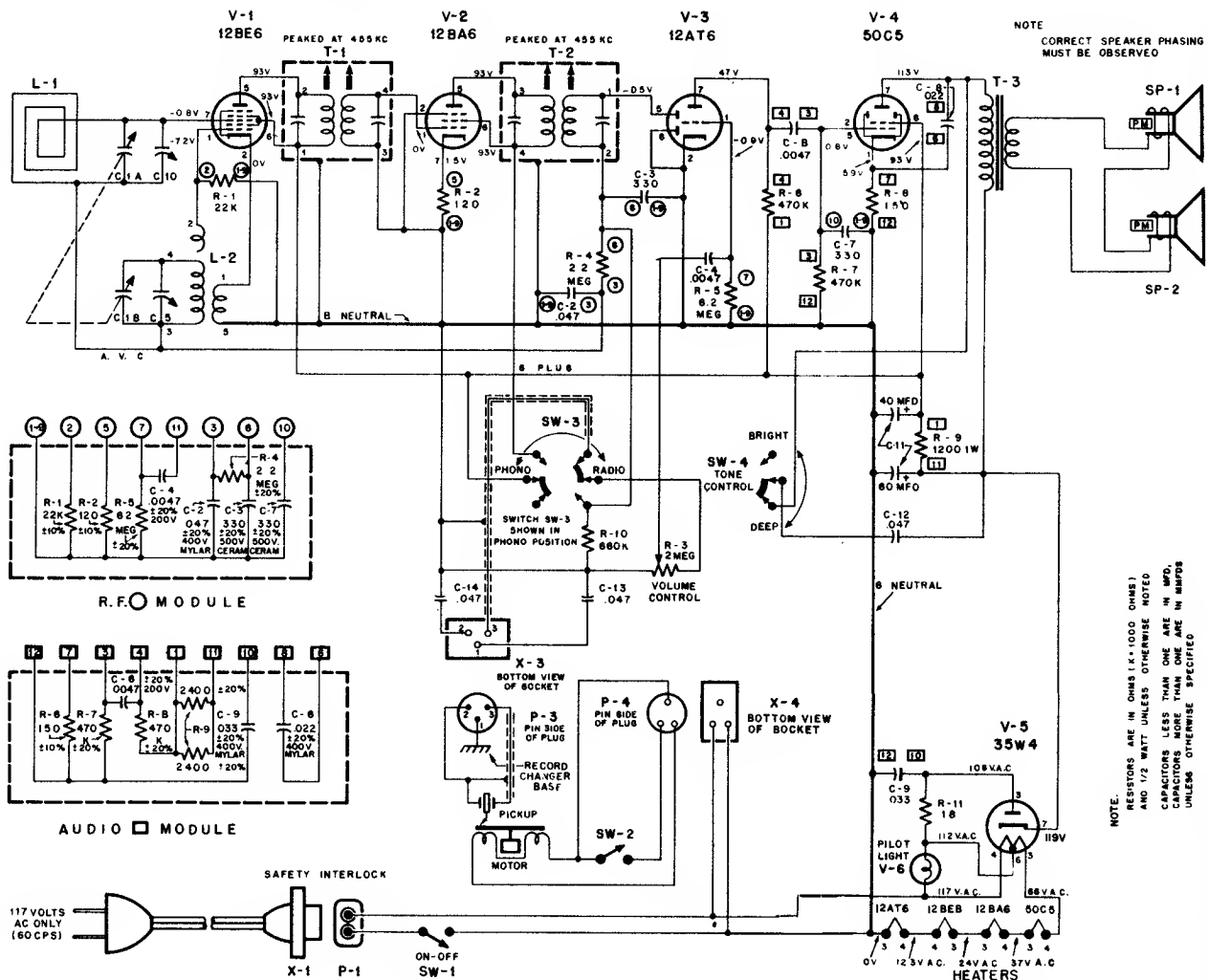

NOTE  
CORRECT SPEAKER PHASING  
MUST BE OBSERVED

NOTE.  
RESISTORS ARE IN OHMS, (E.G., 1000 OHMS) 1  
AND 1/2 WATT UNLESS OTHERWISE NOTED  
CAPACITORS LESS THAN ONE ARE IN MFD,  
CAPACITORS MORE THAN ONE ARE IN MFD,  
UNLESS OTHERWISE SPECIFIED

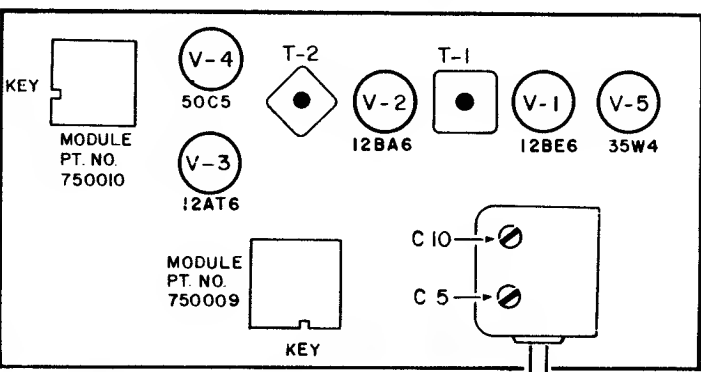

RESISTANCE READING'S CHASSIS 120336B

SYMBOL	TUBE	PIN 1	PIN 2	PIN 3	PIN 4	PIN 5	PIN 6	PIN 7
V-1	12BE6	22K	1	*32	*22	*700K	*700K	3M
V-2	12BA6	15	0	*32	*42	*700K	*700K	120
V-3	12AT6	8.2M	0	0	22	500K	0	*700K
V-4	50C5	15U	470K	*42	*93	500K	*700K	*700K
V-5	35W4	N.C.	N.C.	85	120	135	115	*700K

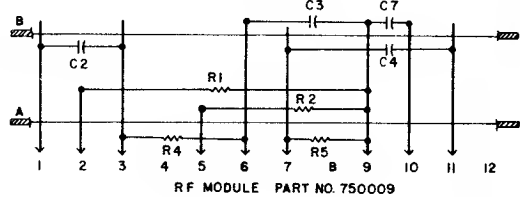

RF MODULE PART NO. 750009

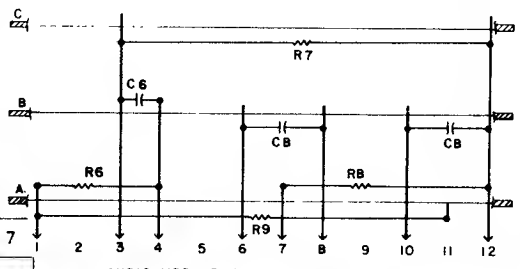

AUDIO MODULE PART NO. 750010

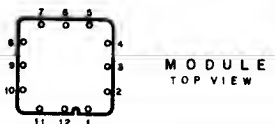

MODULE TOP VIEW

\* Wait for meter to settle



# EMERSON RADIO

MODELS - 860B, 861B, 866B

CHASSIS - 120340B

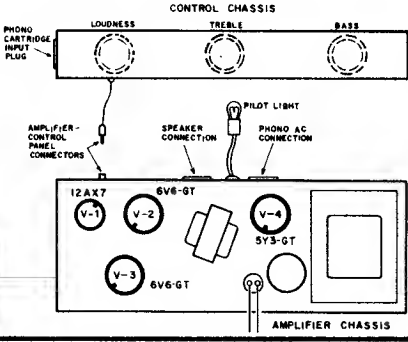
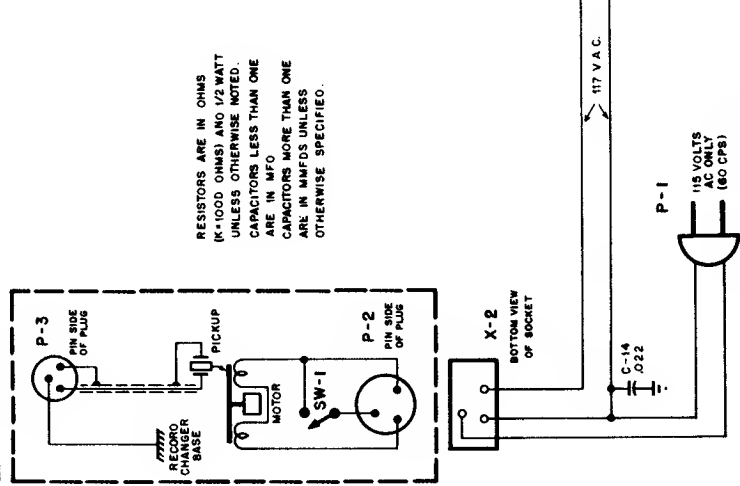
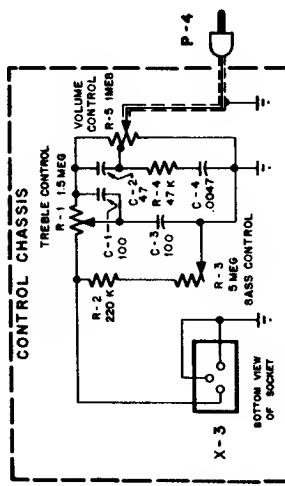
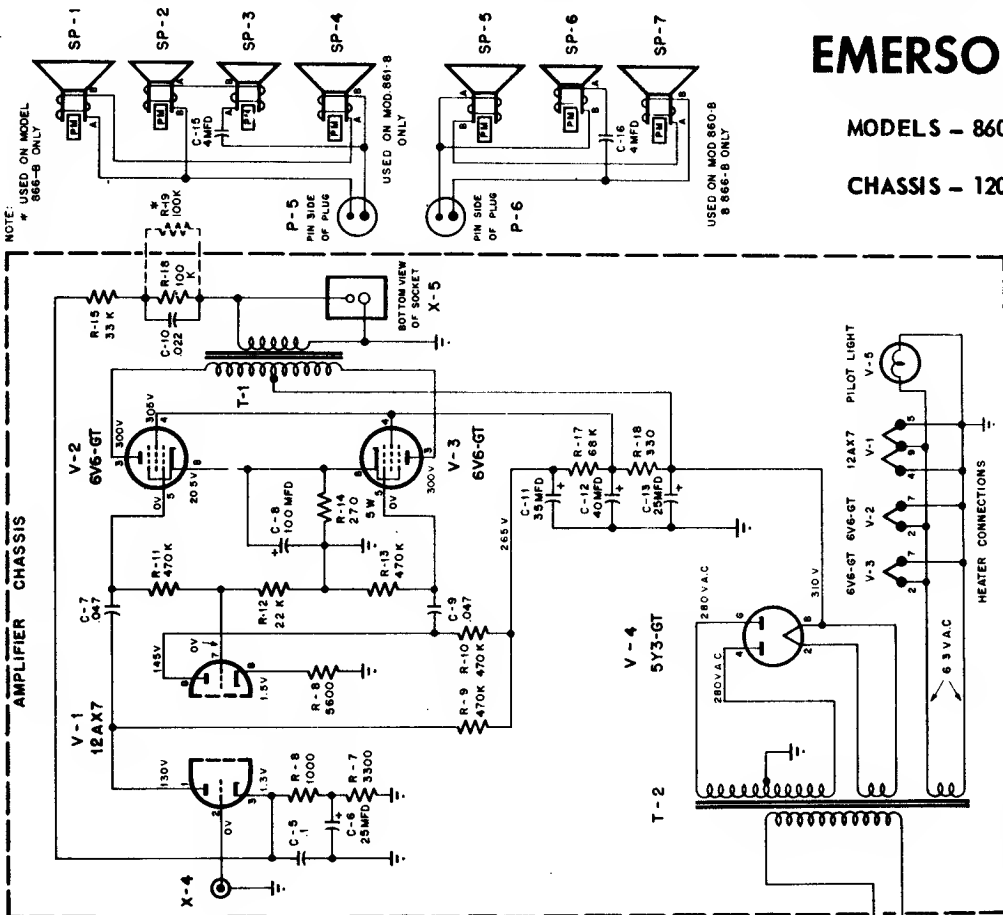

### TO REPLACE STYLUS AND SELECTOR BAR

For best operation and record tracking, it is recommended that the stylus (needle) and selector bar (flip-over arm) be replaced as a single unit rather than the stylus itself. To change this unit, proceed as follows:

1. Lift up tone arm.
2. With one hand, hold spring clip in a direction away from tone arm.
3. With other hand, slide out selector bar and stylus as shown in diagram.
4. To replace new stylus and selector bar, reverse above procedure.

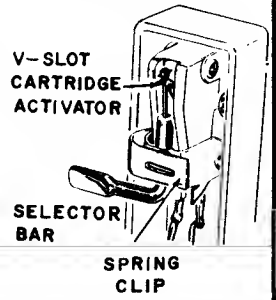

RESISTANCE CHART FOR CHASSIS 120340B

TUBE	SYMBOL	PIN 1	PIN 2	PIN 3	PIN 4	PIN 5	PIN 6	PIN 7	PIN 8	PIN 9
12AX7	V-1	*470K	**0-1 MEG.	4.3K	0	0	*470K	22K	5.6K	0.2
6V6	V-2	0	0.2	*68K	*68K	490K	3.3K	0	270	-
6V6	V-3	INF.	0.2	*68K	*68K	470K	*0	0	270	-
5Y3	V-4	INF.	*68K	INF.	120	INF.	120	INF.	68.3K	-

\* Measured to junction of C-11, R-17.  
\*\* May be slightly less - Depends on setting of bass control.  
All measurements taken from pin to chassis unless otherwise indicated.

**THE FIRESTONE TIRE & RUBBER CO.**

Stock No. 4-B-82  
Code No. 120-6-MP69  
(6 Volt)

Stock No. 4-B-83  
Code No. 120-6-MP126  
(12 Volt)

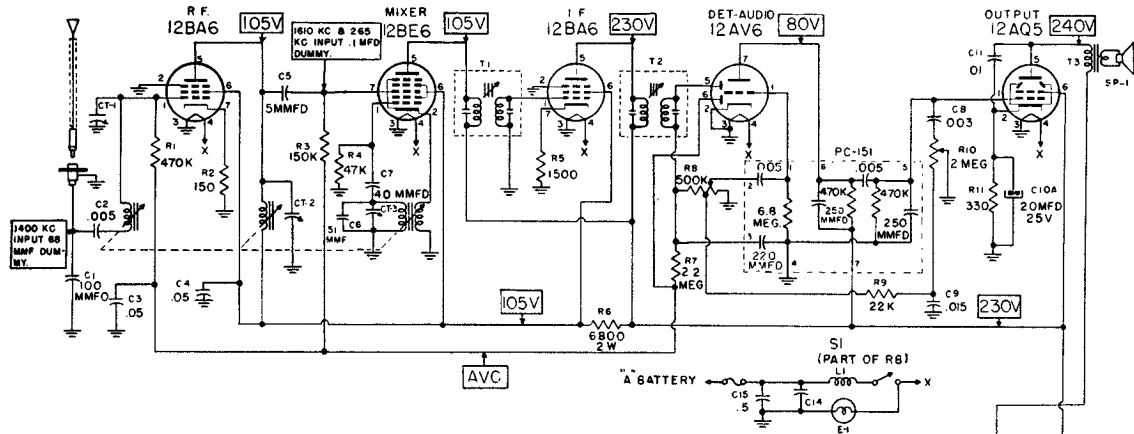

This is an exact schematic for the 12-volt model. The 6-volt model is identical except that the tubes are of the corresponding 6-volt series.

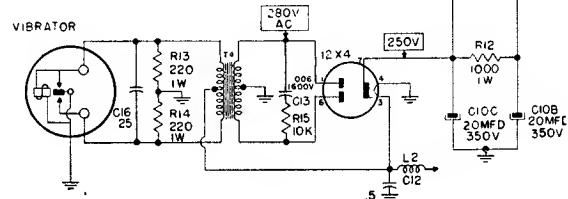

**ALIGNMENT PROCEDURE**

Connect dummy antenna in series with output lead of signal generator.

Connect ground lead of generator to chassis. All adjustments maximum.

For alignment input points refer to schematic diagram.

1. Set receiver dial at extreme high end (1610 KC).  
Adjust T2 top and bottom at 265 KC.  
Adjust T1 top and bottom at 265 KC.  
Adjust CT-3 for 1610 KC.
2. Tune in 1400 KC signal from generator.  
Adjust CT-1 and CT-2 (68 MMFD dummy).
3. After installing radio in car, re-trim CT-1 on weak station near 1400 KC with antenna fully extended.

**PUSH-BUTTON OPERATION**

To set any push-button, pull the button straight out, select the desired station with the STATION SELECTOR KNOB and press in the push-button. Any push-button may be re-set at any time without disturbing the setting of the other buttons.

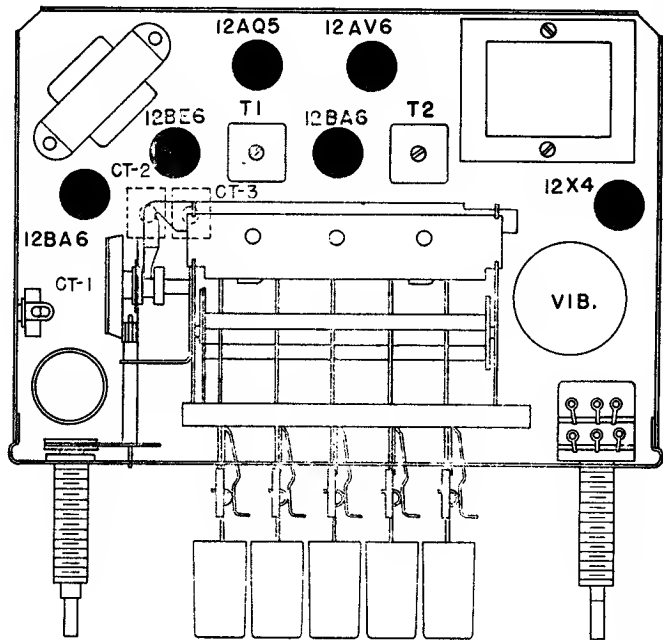

Tube and Trimmer Locations

**THE FIRESTONE TIRE & RUBBER CO.**  
**STOCK NO. 4-C-29**      **CODE NO. 120-6-TT600**

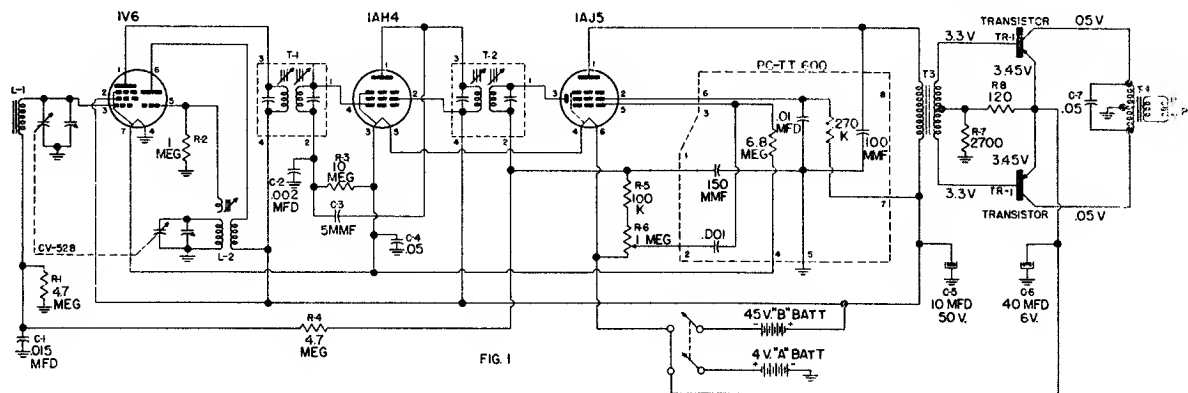

FIG. 1

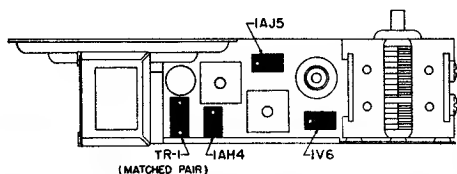

FIG. 2

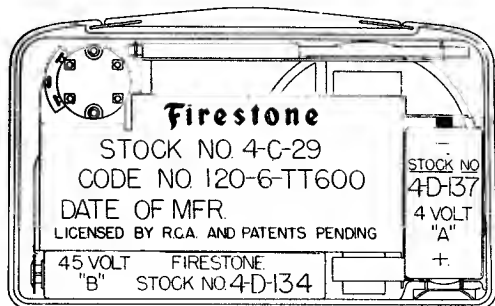

FIG. 3

**TO REPLACE TUBES OR SERVICE**

The chassis should be removed in the following manner:

1. Turn off receiver. Close the variable gang condenser by setting the tuning knob to 5.5 on the dial scale.
2. Remove the back cover and batteries.
3. Remove the speaker securing bracket by removing the two round-head screws from the "A" battery side of the receiver.
4. Remove the tuning knob by pulling the knob straight off the tuning shaft.
5. Remove the three flat head mounting screws underneath the tuning knob.
6. When replacing tubes be sure red dot on tube base is positioned to match dot of tube location chart, Fig. 2.

**ALIGNMENT PROCEDURE**

Volume control — Maximum, all adjustments.

Connect dummy antenna in series with output lead of signal generator.

No signal applied to antenna.

Connect ground lead of signal generator to chassis.

Dial Setting	Generator Frequency	Dummy Ant.	Generator Connection	Trimmer Adjustment	Trimmer Function
1. Fully open	455 KC	.1 MFD	1AH4 Grid	Maximum	Output I.F. Top & Bottom
2. Fully open	455 KC	.1 MFD	1V6 Grid	Maximum	Input I.F. Top & Bottom
3. Fully open	1610 KC	.1 MFD	1V6 Grid	Maximum	Oscillator Trimmer
4. Tune in signal from generator	1400 KC		Loosely couple signal generator to "Magna Loop"	Maximum	Antenna Trimmer

Repeat alignment procedure as a final check.

# GAMBLE-SKOGMO INC.

## MODEL RA 48-8342A

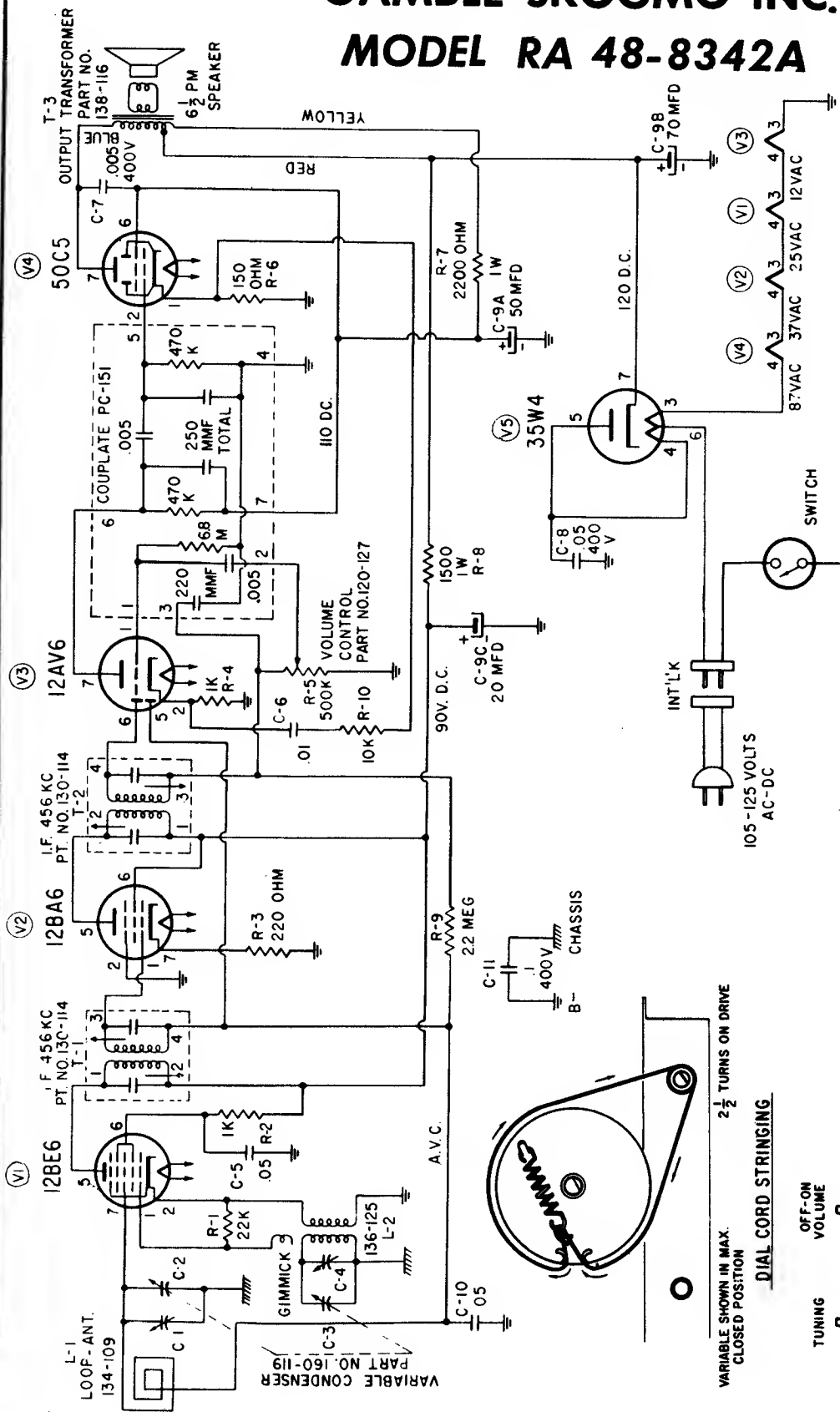

### ELECTRICAL SPECIFICATIONS

Power Supply	105-120 Volts AC-DC
Frequency Range	540-1650 KC
Intermediate Frequency	456 KC
Sensitivity	60 microvolts on loop for 50 MW output
Selectivity	8 KC 2X - 20 KC 10X at 456 KC
Tuning	2 Gang Capacitor
Power Consumption	30 Watts
Power Output	1.9 Watt, undistorted

### NOTES:

- K-1000 OHMS
- M-MEGOHMS
- ALL VALUES OF "C" ARE IN MICROFARADS UNLESS OTHERWISE NOTED
- ⊖ DENOTES B-
- ⊕ DENOTES CHASSIS GROUND

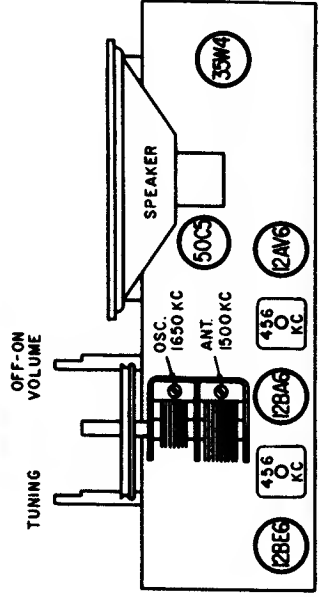
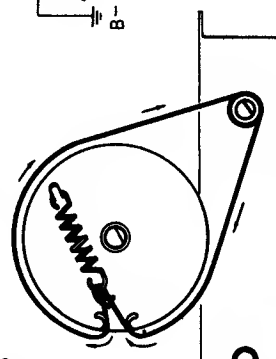

# GENERAL ELECTRIC

Models P720 and P721

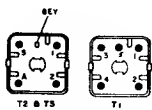
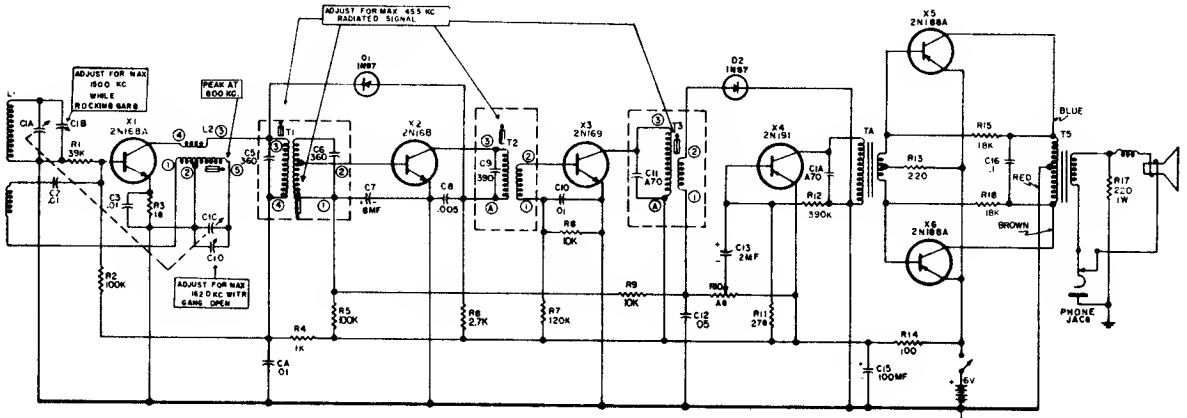

UNLESS OTHERWISE NOTED  
 K=1,000 M=1,000,000  
 CAPACITORS MORE THAN 1 MF  
 CAPACITORS LESS THAN 1 MF  
 RESISTORS 1/2 W CARBON

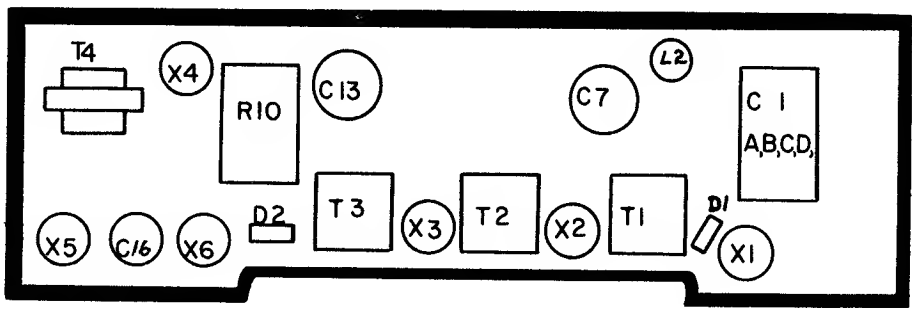
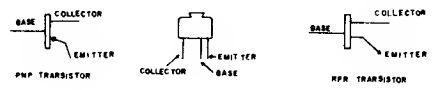

# GENERAL ELECTRIC

Models P715 and P716

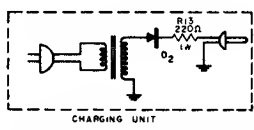
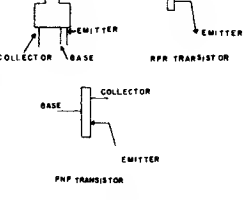
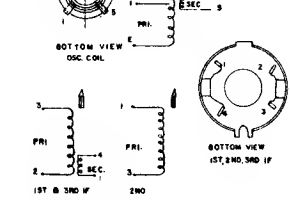
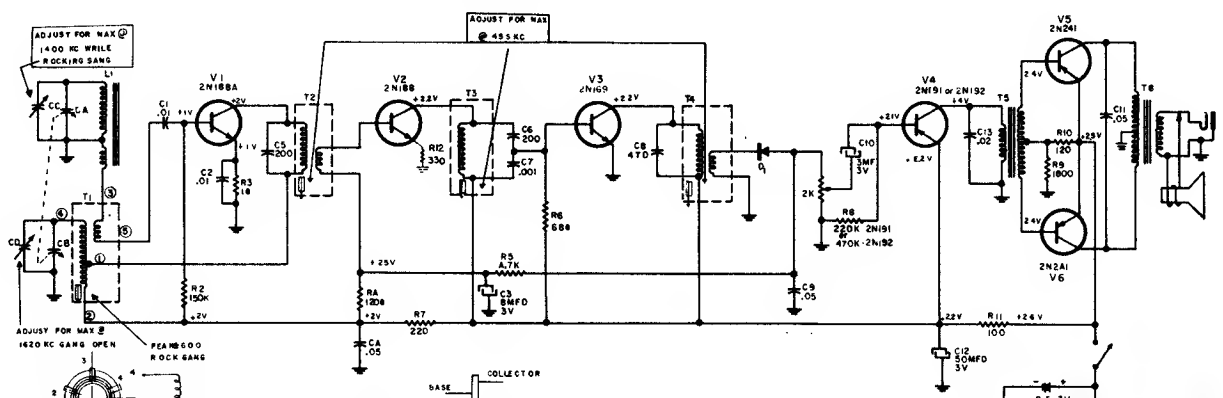

VOLTAGES TAKEN WITH TYPE AA RECHARGEABLE CELLS  
 IN PLACE ON 20,000 OHMS VOLTMETER NO SPEAKER  
 OR ANTENNA CONNECTED VOLTAGES ARE APPROXIMATE

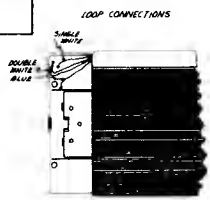

# GENERAL ELECTRIC

Model 850

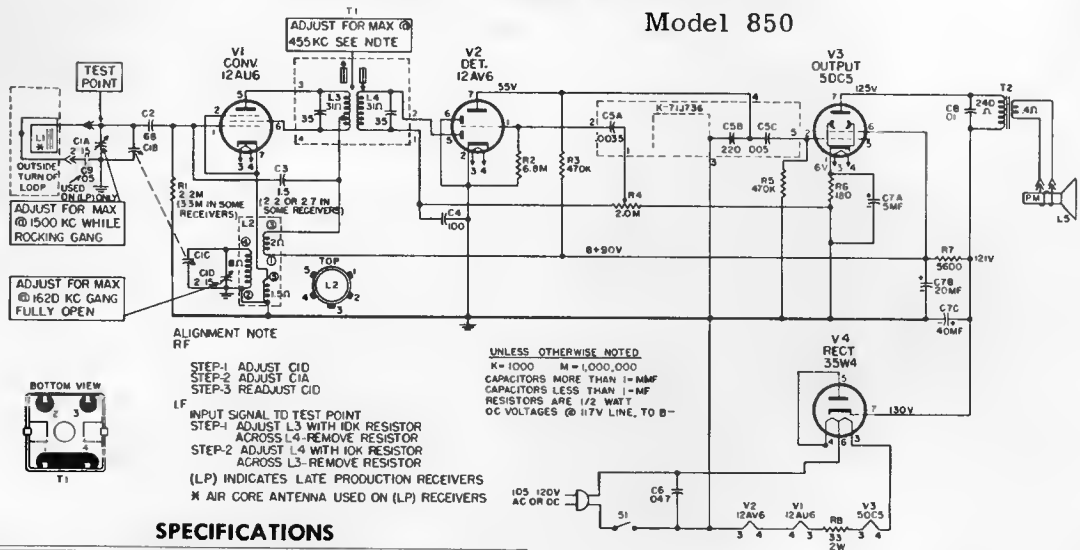

## SPECIFICATIONS

<b>INPUT:</b>	105-120 Volts A-C or D-C, 25 watts
<b>OPERATING FREQUENCIES:</b>	Tuning Range . . . . . 540 to 1600 KC I.F. . . . . 455 KC
<b>OUTPUT:</b>	Undistorted .8 watts, maximum 1.5 watts
<b>SPEAKER:</b>	4-inch PM, 3.2 ohms, @ 400 cps.

## TO REMOVE CHASSIS FROM CABINET

Remove cabinet back and interlock. Remove the four self-tapping screws (hex heads), one on each corner of the chassis, and the single hex screw just below the tuning gang capacitor. Pull off the volume control knob. The tuning control knob is captivated to the cabinet, so the chassis must be pulled out of the cabinet, at the same time pulling it off the tuning knob, which remains on the cabinet. When pulling out the chassis, it is best to grasp the tuning capacitor (C1) by the thumb and forefinger of one hand and the tuning knob by the other hand and pull.

**CAUTION:** It is important to use extreme care while replacing parts and/or soldering on this chassis. Too much heat on the chassis will cause the copper plating to become unbonded. Only apply the soldering iron long enough to melt the solder and pull out the part to be replaced.

**NOTE:** The shield can on T1 may be removed by unfastening the two spring clips and lifting the can off the transformer, thereby leaving the coils open for inspection or repair.

## TO REPLACE A TUBE SOCKET

Cut the socket free by cutting all of the socket terminals at the chassis and unsolder the center terminal. Now, heat each terminal only enough to push it out. The new socket can now be inserted into the holes left by the old one and soldered into place.

## TO REPLACE THE VOLUME CONTROL

Remove the shaft nut, then cut the center and lower terminals. Apply only enough heat to the upper terminal to pull out the control. Apply heat to the center and lower terminals so they may be pushed out. The new control may now be inserted into place and soldered.

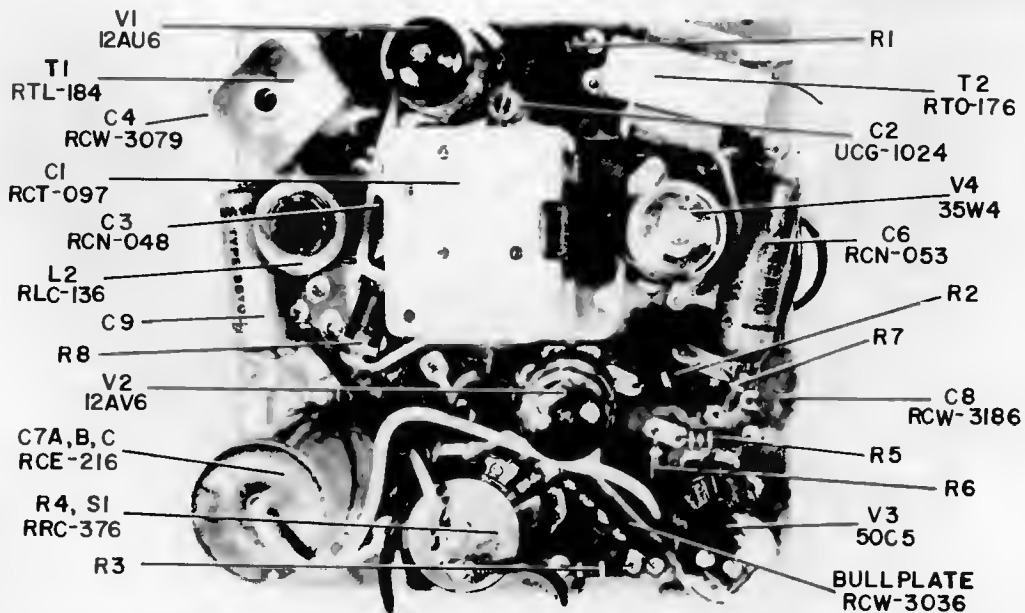

# GENERAL ELECTRIC ELECTRIC

**MODELS**  
870  
871

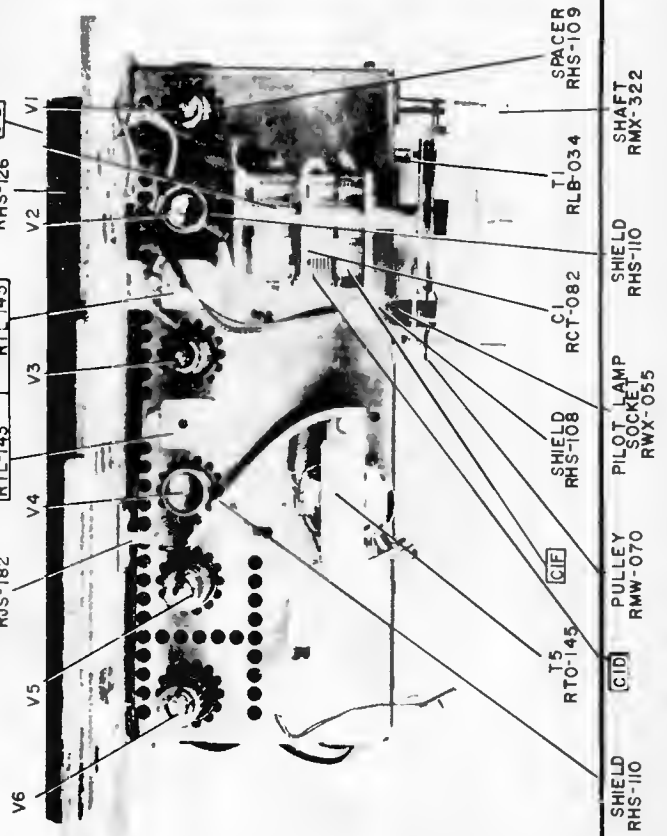
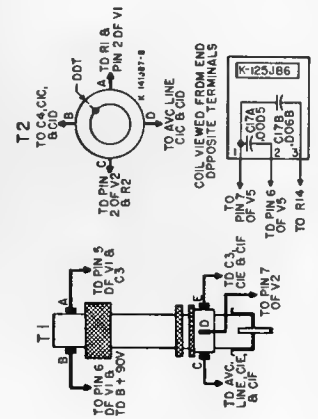
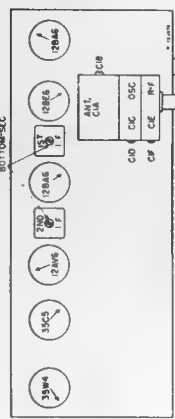
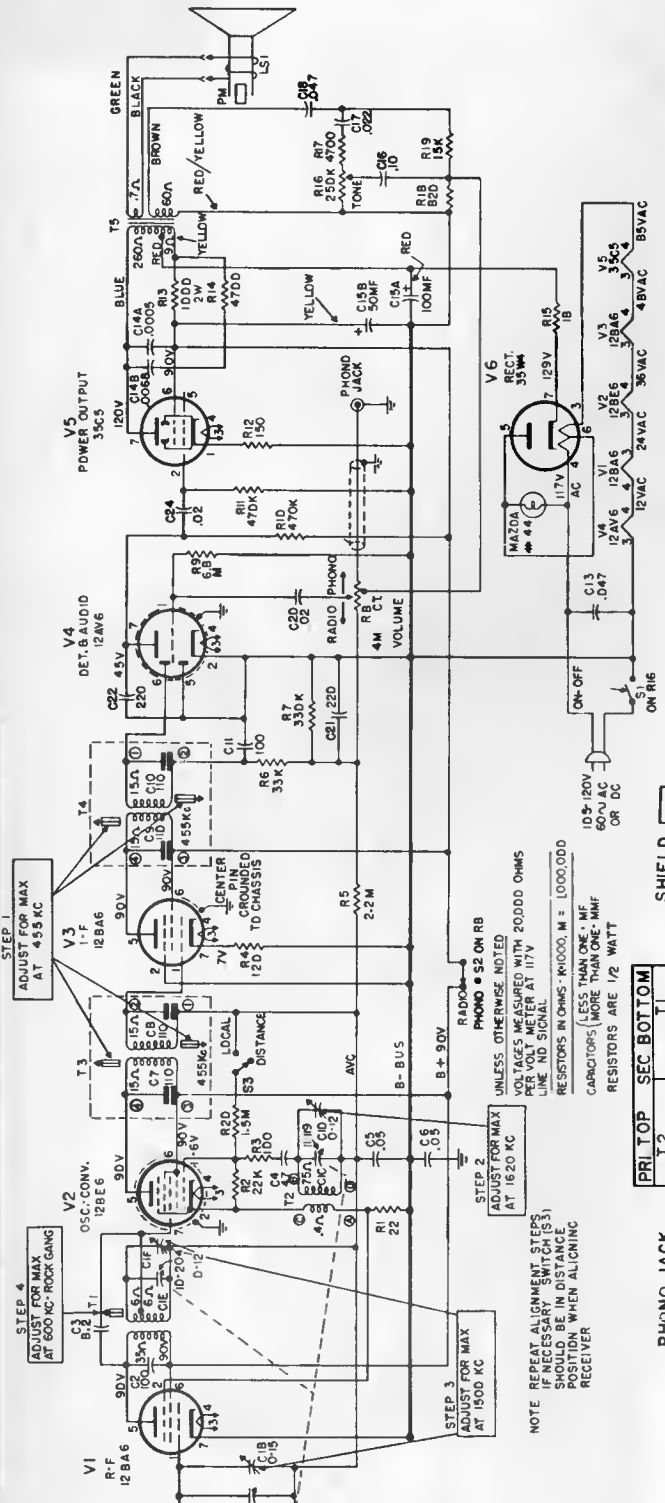
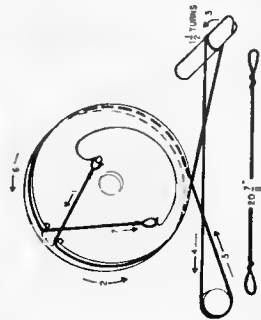

- V1 SHIELD RHS-110
- V2 SHIELD RHS-108
- V3 SHIELD RHS-108
- V4 SHIELD RHS-108
- V5 PHONO JACK RJS-182
- V6 SHIELD RHS-126
- T1 SHIELD RHS-109
- T2 SHIELD RHS-109
- T3 SHIELD RHS-109
- T4 SHIELD RHS-109
- T5 SHIELD RHS-109
- T6 SHIELD RHS-109
- T7 SHIELD RHS-109
- T8 SHIELD RHS-109
- T9 SHIELD RHS-109
- T10 SHIELD RHS-109
- T11 SHIELD RHS-109
- T12 SHIELD RHS-109
- T13 SHIELD RHS-109
- T14 SHIELD RHS-109
- T15 SHIELD RHS-109
- T16 SHIELD RHS-109
- T17 SHIELD RHS-109
- T18 SHIELD RHS-109
- T19 SHIELD RHS-109
- T20 SHIELD RHS-109
- T21 SHIELD RHS-109
- T22 SHIELD RHS-109
- T23 SHIELD RHS-109
- T24 SHIELD RHS-109
- T25 SHIELD RHS-109
- T26 SHIELD RHS-109
- T27 SHIELD RHS-109
- T28 SHIELD RHS-109
- T29 SHIELD RHS-109
- T30 SHIELD RHS-109
- T31 SHIELD RHS-109
- T32 SHIELD RHS-109
- T33 SHIELD RHS-109
- T34 SHIELD RHS-109
- T35 SHIELD RHS-109
- T36 SHIELD RHS-109
- T37 SHIELD RHS-109
- T38 SHIELD RHS-109
- T39 SHIELD RHS-109
- T40 SHIELD RHS-109
- T41 SHIELD RHS-109
- T42 SHIELD RHS-109
- T43 SHIELD RHS-109
- T44 SHIELD RHS-109
- T45 SHIELD RHS-109
- T46 SHIELD RHS-109
- T47 SHIELD RHS-109
- T48 SHIELD RHS-109
- T49 SHIELD RHS-109
- T50 SHIELD RHS-109
- T51 SHIELD RHS-109
- T52 SHIELD RHS-109
- T53 SHIELD RHS-109
- T54 SHIELD RHS-109
- T55 SHIELD RHS-109
- T56 SHIELD RHS-109
- T57 SHIELD RHS-109
- T58 SHIELD RHS-109
- T59 SHIELD RHS-109
- T60 SHIELD RHS-109
- T61 SHIELD RHS-109
- T62 SHIELD RHS-109
- T63 SHIELD RHS-109
- T64 SHIELD RHS-109
- T65 SHIELD RHS-109
- T66 SHIELD RHS-109
- T67 SHIELD RHS-109
- T68 SHIELD RHS-109
- T69 SHIELD RHS-109
- T70 SHIELD RHS-109
- T71 SHIELD RHS-109
- T72 SHIELD RHS-109
- T73 SHIELD RHS-109
- T74 SHIELD RHS-109
- T75 SHIELD RHS-109
- T76 SHIELD RHS-109
- T77 SHIELD RHS-109
- T78 SHIELD RHS-109
- T79 SHIELD RHS-109
- T80 SHIELD RHS-109
- T81 SHIELD RHS-109
- T82 SHIELD RHS-109
- T83 SHIELD RHS-109
- T84 SHIELD RHS-109
- T85 SHIELD RHS-109
- T86 SHIELD RHS-109
- T87 SHIELD RHS-109
- T88 SHIELD RHS-109
- T89 SHIELD RHS-109
- T90 SHIELD RHS-109
- T91 SHIELD RHS-109
- T92 SHIELD RHS-109
- T93 SHIELD RHS-109
- T94 SHIELD RHS-109
- T95 SHIELD RHS-109
- T96 SHIELD RHS-109
- T97 SHIELD RHS-109
- T98 SHIELD RHS-109
- T99 SHIELD RHS-109
- T100 SHIELD RHS-109

# GENERAL ELECTRIC ELECTRIC

MODELS

955  
956

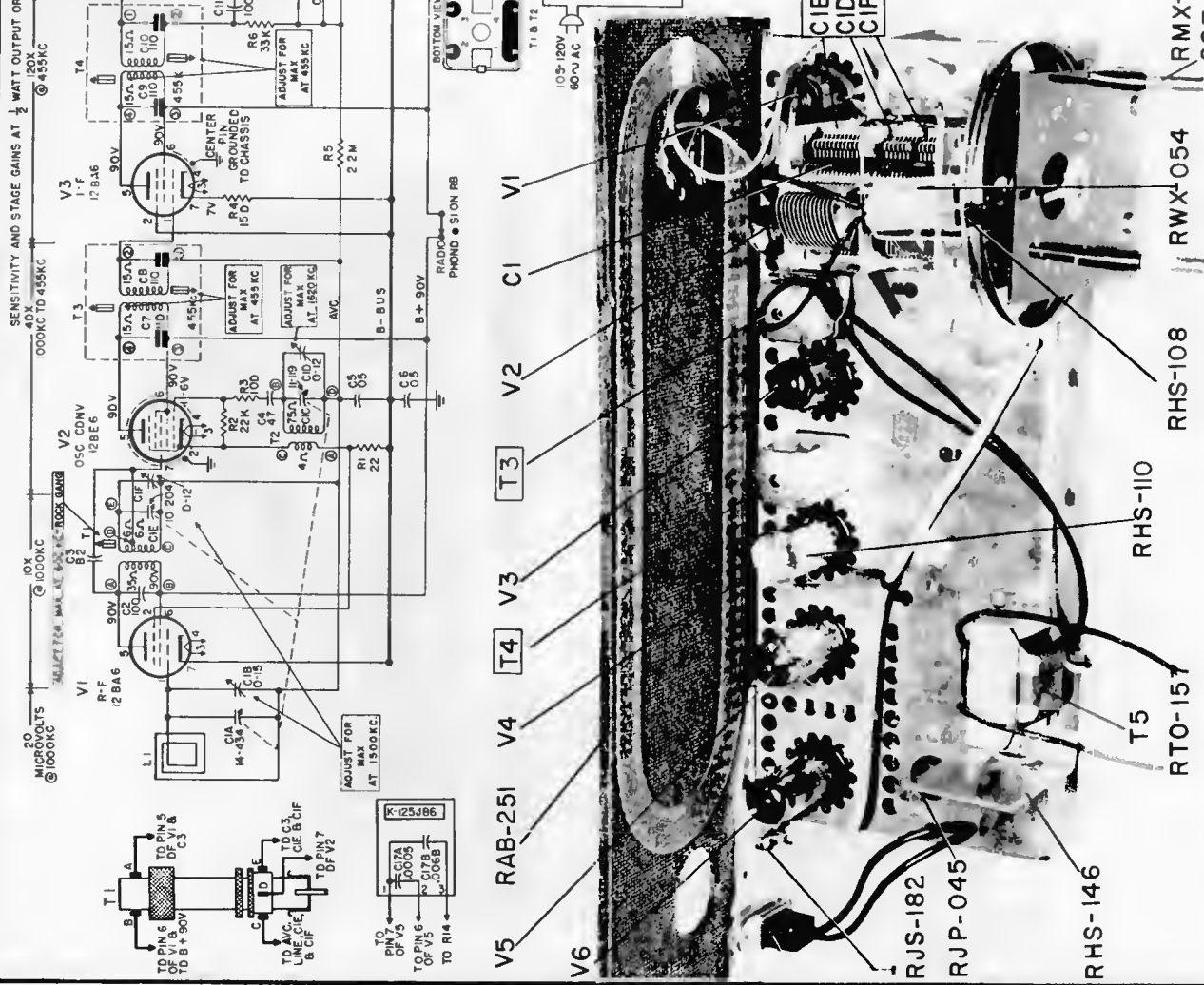
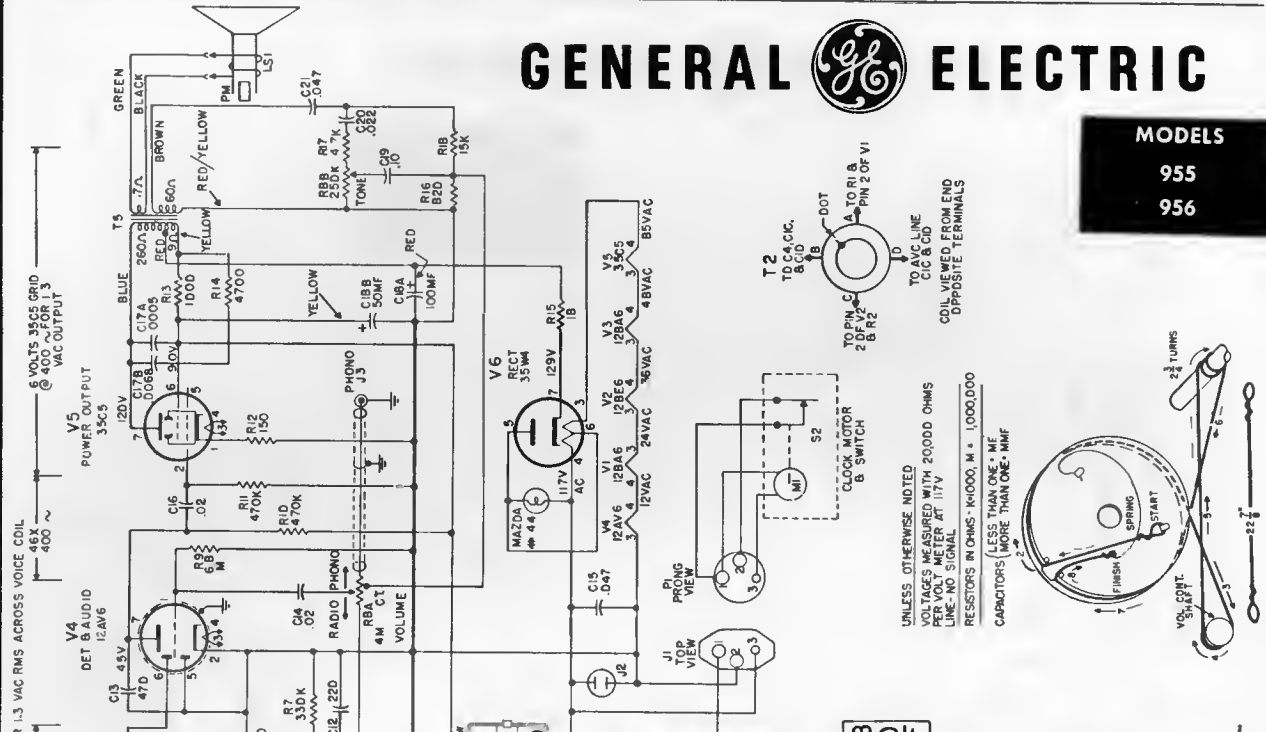



# GENERAL ELECTRIC

Models 930, 935, 936, Clock Radios  
 Models 455S, 456S, 457S, 875, 876, 877,  
 are electrically identical to this group but  
 omit clock motor and switch and incorpo-  
 rate a switch on R3.

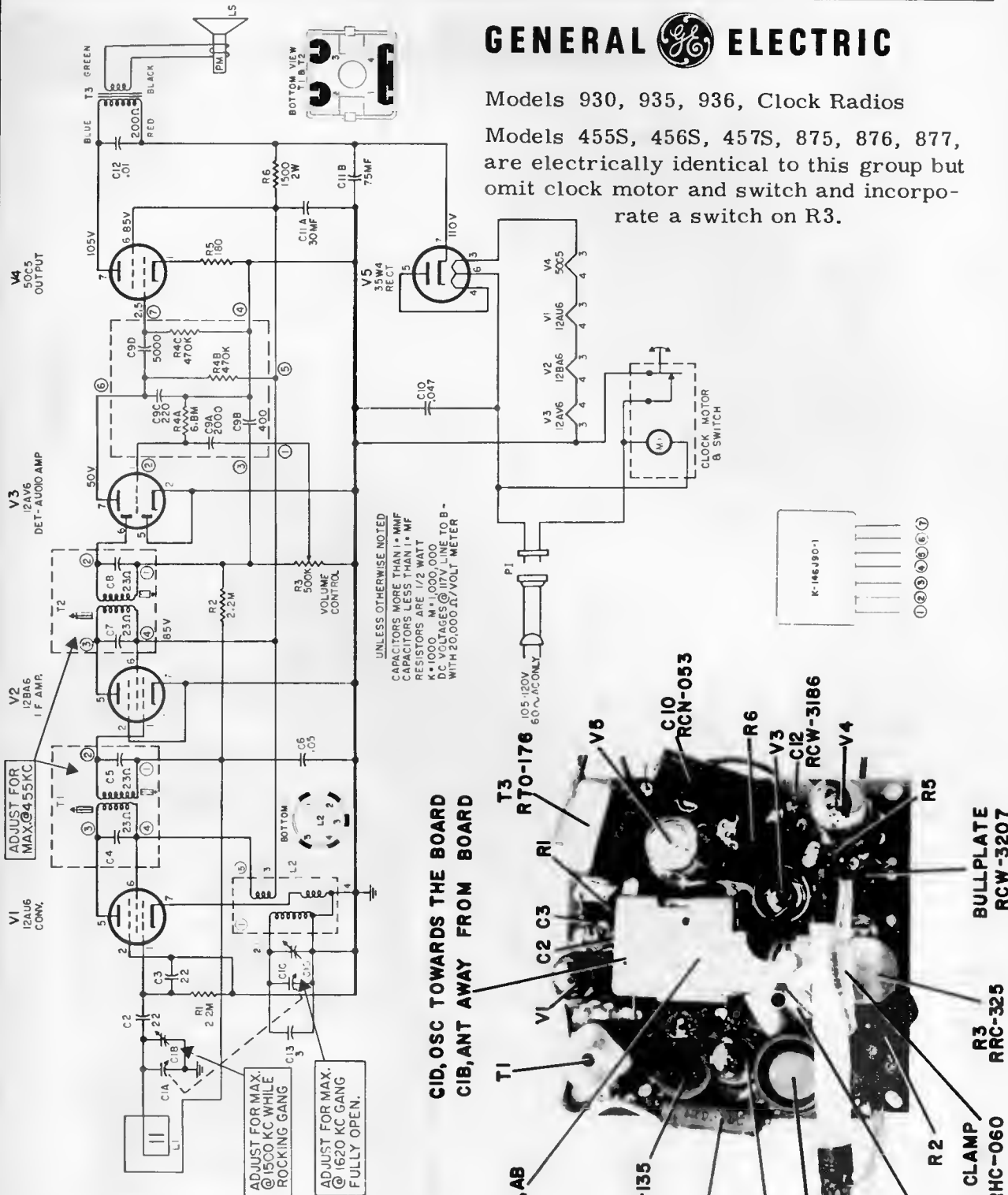

# GENERAL ELECTRIC

**MODELS**  
940  
941  
942

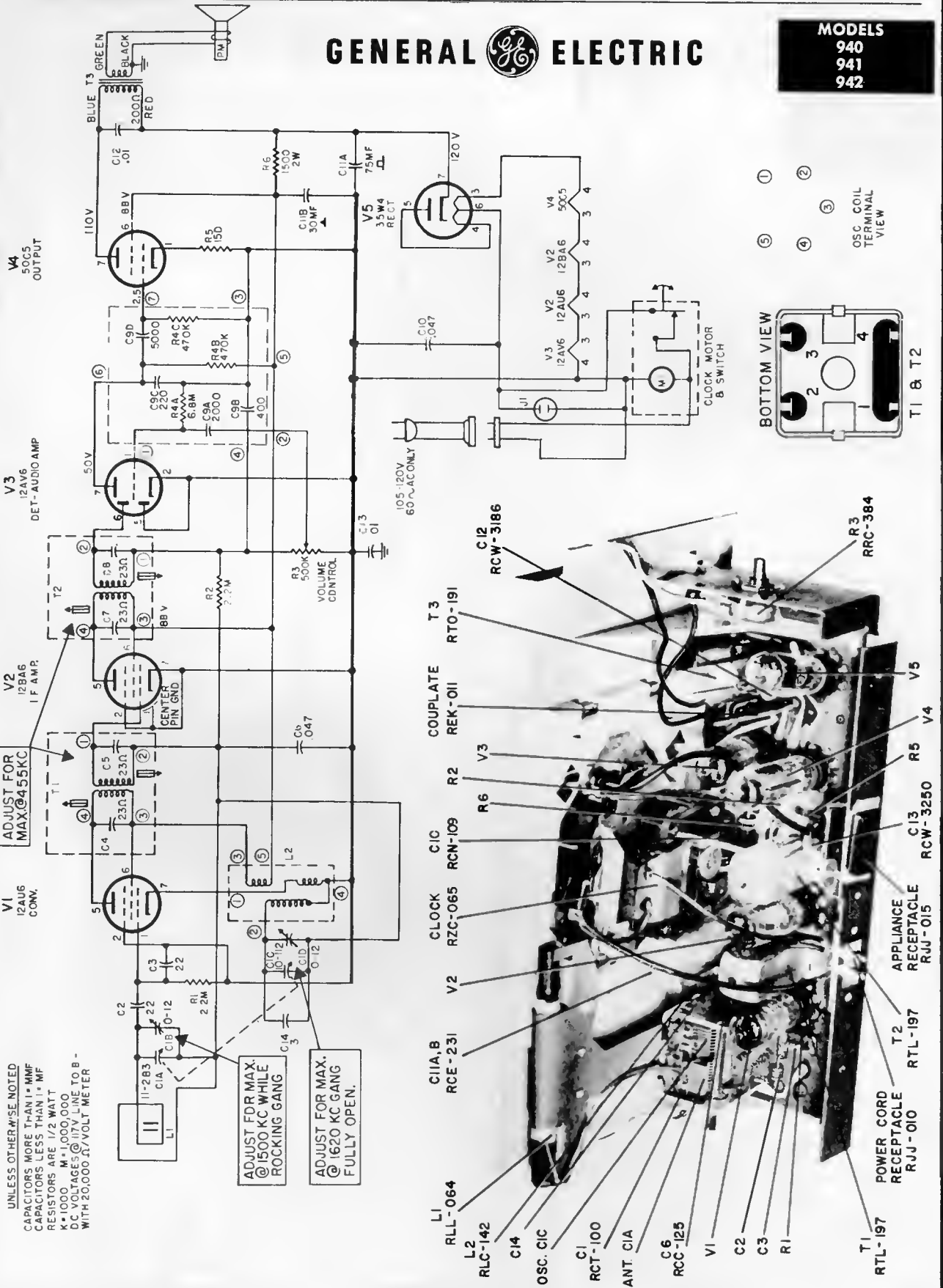

GRANCO PRODUCTS Model 750 AM-FM

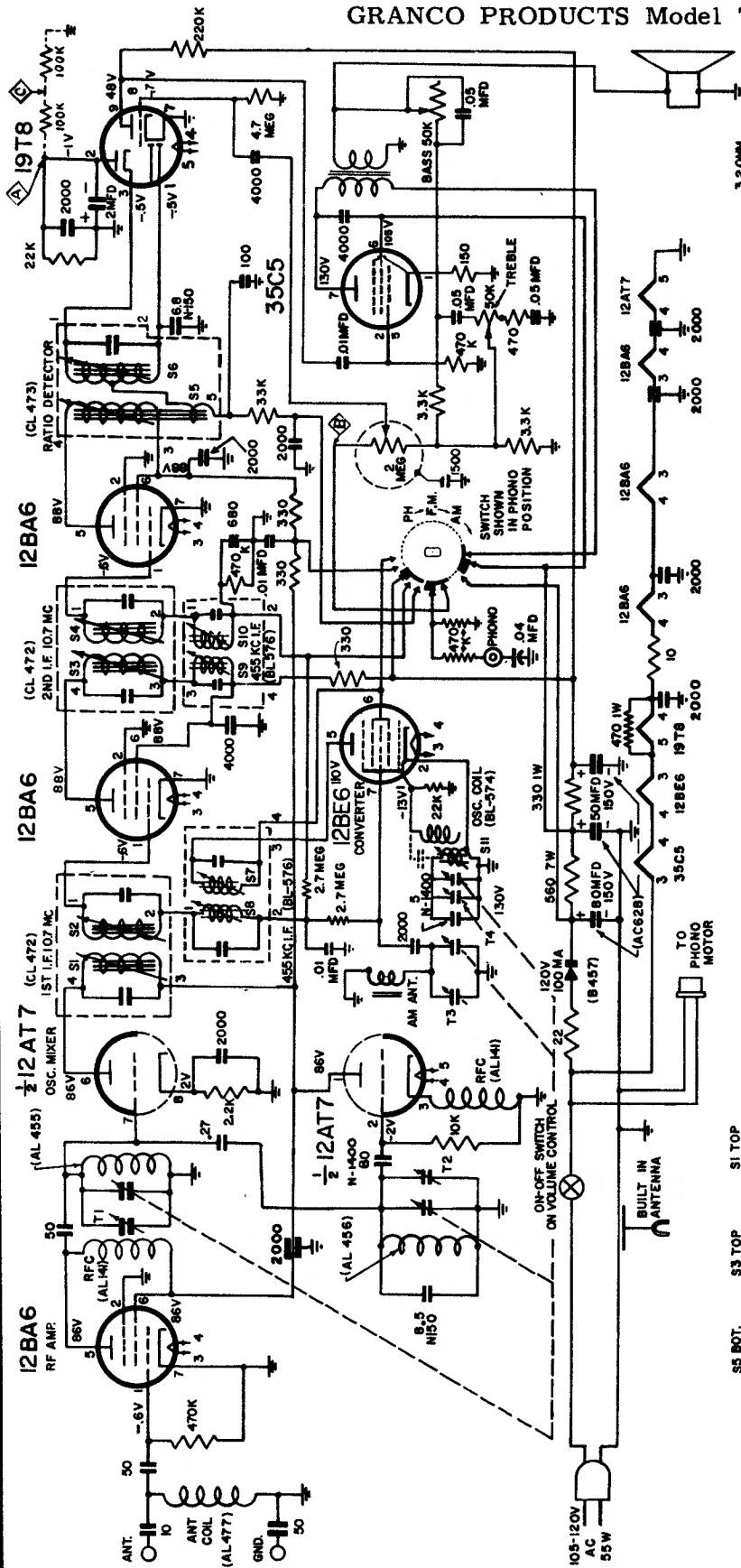

NOTES—  
 ALL RESISTORS 1/2 WATT 20%  
 UNLESS OTHERWISE SPECIFIED  
 ALL CONDENSER VALUES IN MMF  
 UNLESS OTHERWISE SPECIFIED  
 GRANCO PART NO. SHOWN IN (—)

CONDITIONS FOR MEASURING VOLTAGES  
 ADJUST LINE VOLTAGE TO 117V.  
 NO SIGNAL INPUT ON F. M.  
 USE UTILITY  
 ALL VOLTAGES MEASURED WITH  
 RESPECT TO CHASSIS GROUND

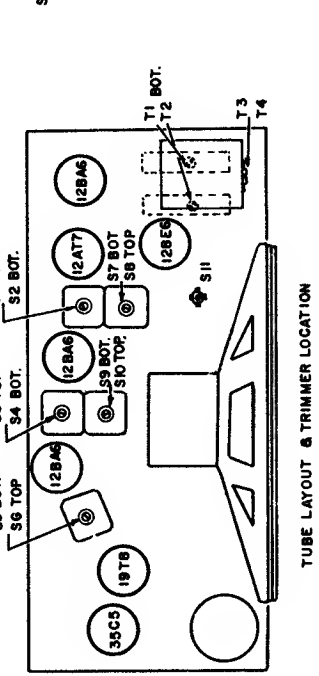
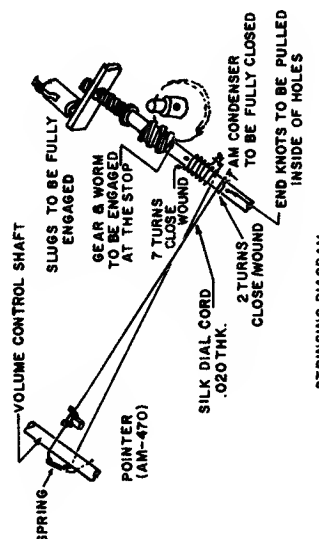

STRINGING DIAGRAM

**GRANCO PRODUCTS INC.**

MODEL 750 AM-FM

# the hallicrafters TR-88 TRANSISTOR RADIO

(Continued on the next page)

NOTE: ALL VOLTAGES TAKEN WITH VTVM AND NO SIGNAL. ALL RESISTORS 1/2 WATT ± 10%

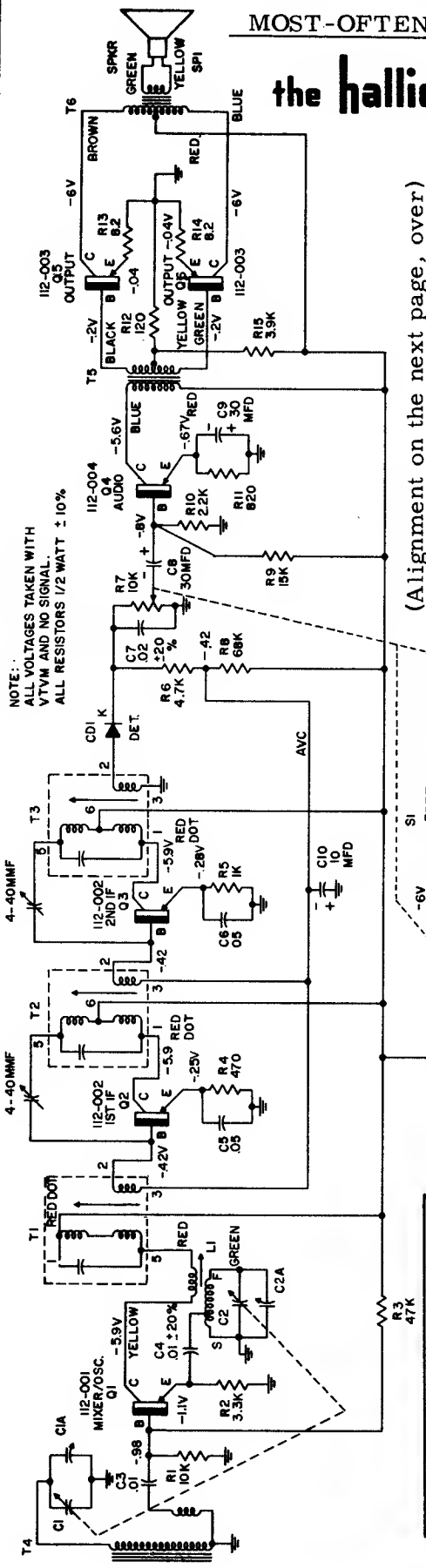

(Alignment on the next page, over)

## OSCILLATOR COUPLING

The oscillator injection voltage is variable by changing the coupling between the windings of the oscillator coil. The injection voltage should be checked:

1. Whenever the MIXER/OSC transistor, Q<sub>1</sub> is replaced.
2. If the receiver will not operate properly when the battery supply voltage drops to approximately 4 volts.
3. If the receiver is lacking in sensitivity at the low frequency end of the dial or has "squaging" near the high end of the dial.

## ADJUSTMENT

The coupling between windings of the oscillator coil has been factory set to provide an oscillator injection voltage (as measured across R<sub>2</sub> with a sensitive R-F voltmeter) of 60 millivolts. The injection voltage is set with the tuning gang closed, and a battery supply voltage of a full 6 volts. With the tuning gang open the reading should not exceed 150 millivolts.

If careful measurement reveals that the injection voltage is not within the approximate factory set range it may be corrected simply by loosening the wax seal on the coupling winding and moving it a short distance as required. Be sure to reseal the winding in position when the adjustment has been completed.

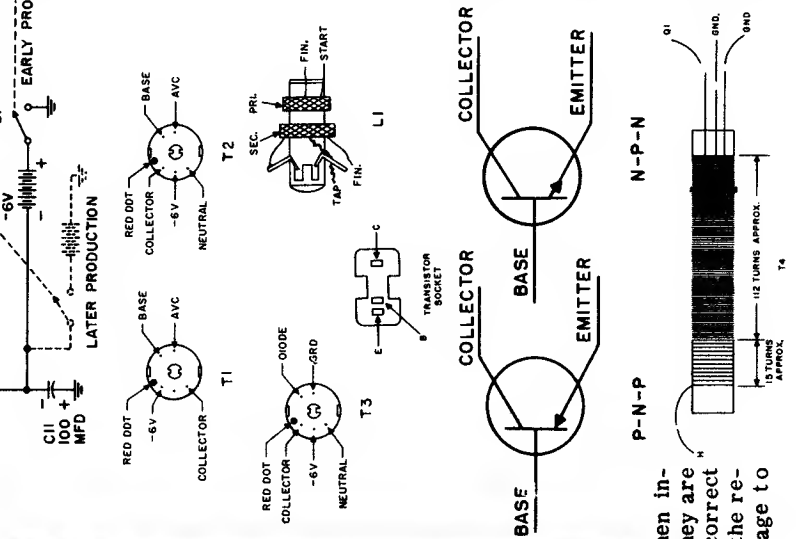

**CAUTION:** Always consult figure when installing the batteries and be sure that they are placed in the clips exactly as shown. Incorrect placement of the batteries will make the receiver inoperative and will cause damage to some of its parts.

the **hallicrafters** co.

# TR-88 TRANSISTOR RADIO

(Continued from the preceding page)

## IF ALIGNMENT

STEP	SIGNAL GENERATOR CONNECTIONS	GENERATOR FREQUENCY	RECEIVER DIAL SETTING	ADJUST	REMARKS
1	Across secondary of stick-loop ant. (terminal strip on top side of chassis).	455 KC modulated	Tuning gang open.	A, B & C i-f slugs	Tune for maximum output.
2	Same as step 1.	Same as step 1	Slowly tune over entire range.	E & D Neutralizing adj.	Adjust so that no oscillation occurs throughout the tuning range.

I-F oscillation will appear in the output, as heard in the speaker, as distortion that may range from "motor boating" to howl. Some compromise adjustment of the i-f slugs A, B & C, may be required to permit neutralization over the entire tuning range.

## RF ALIGNMENT

3	Loosly couple to stick-loop antenna.	1620 KC modulated	Tuning gang open.	G, Osc, trimmer	Tune for maximum output.
4	Same as step 3.	535 KC modulated	Tuning gang closed.	F, Osc. Coil slug	Same as step 3.
5	Same as step 3.	1400 KC modulated	1400 KC	H, Ant. trimmer	Same as step 3.

## TRANSISTOR SUBSTITUTION CHART

Hallicrafter Part	General Transistor	G. E.	Raytheon	RCA	Texas Inst.
112-001	GT 761	2N136	760, 2N112, CK 761	--	--
112-002	GT 760	2N135	CK760, 2N112 CK760	2N139	--
112-003*	GT2N109	2N186	--	2N109	2N109, 352
112-004	GT81, 2N109	2N191		2N109	310

\* The audio output transistors were installed at the factory as a matched pair. If replacement of either unit becomes necessary it is recommended that a new matched pair be installed.

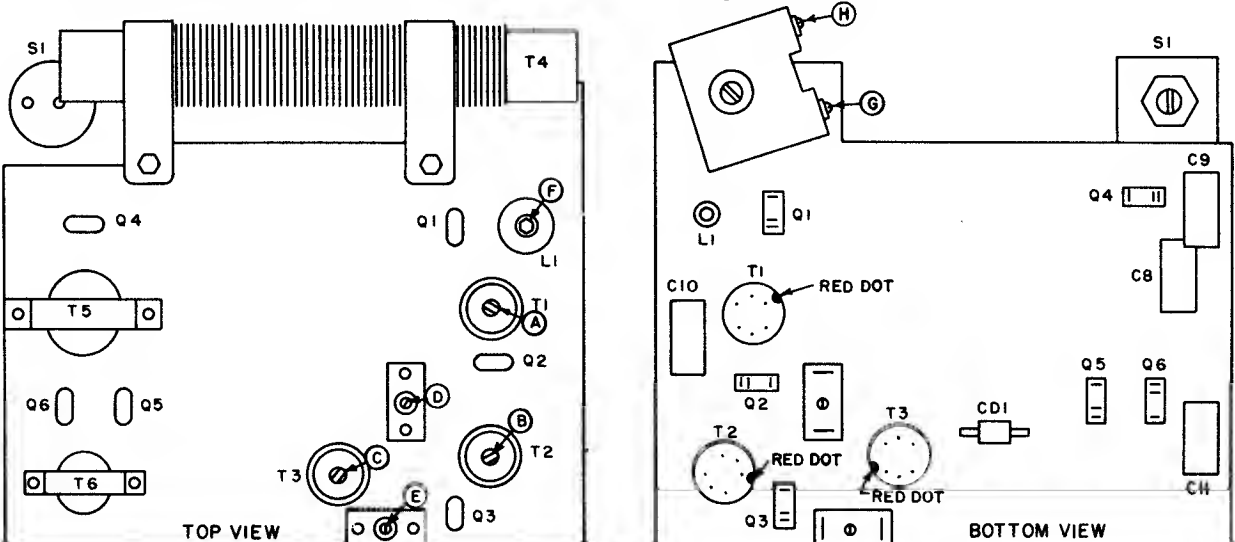

# Magnavox Type AM2 Radio

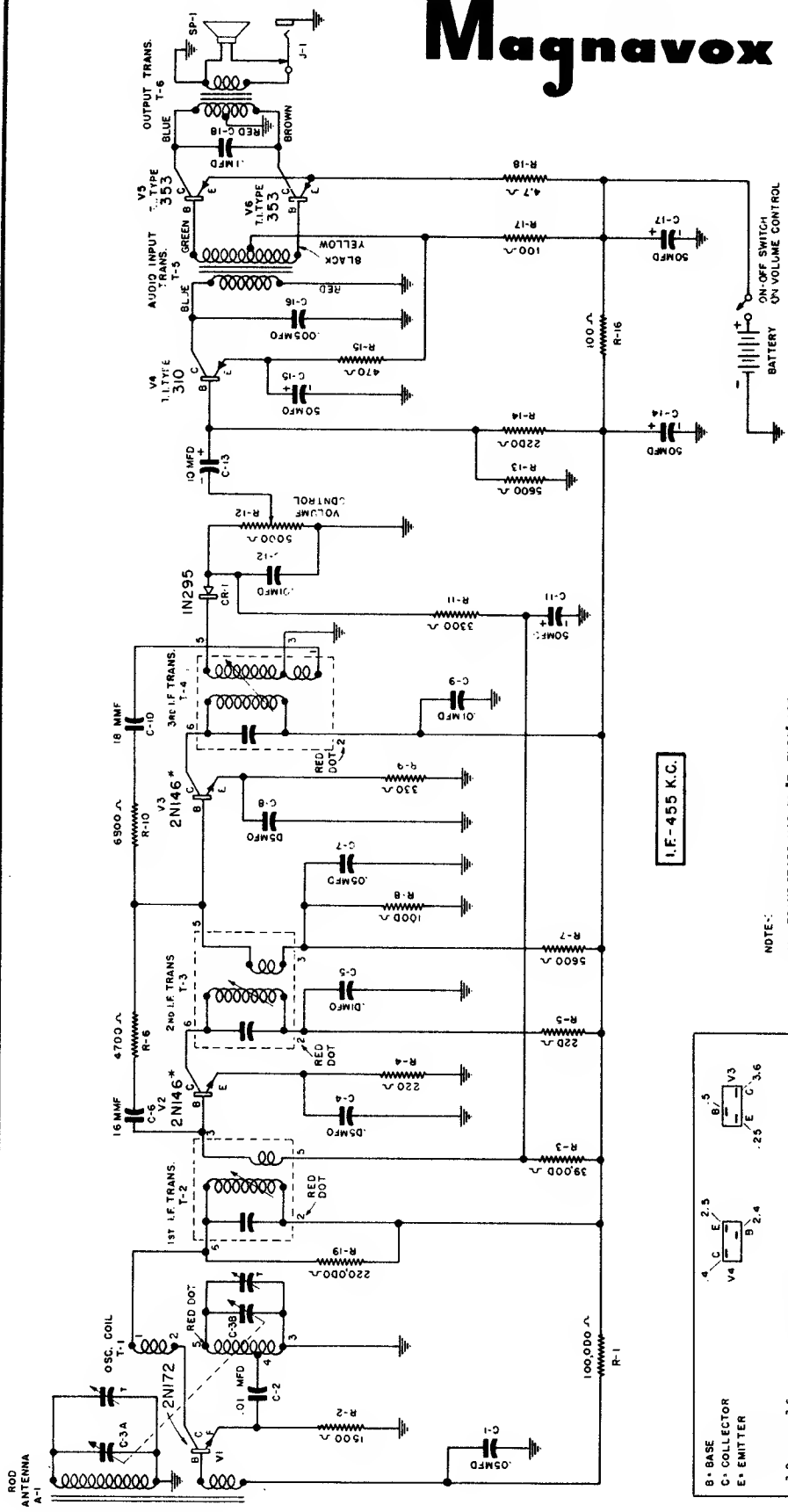

\* WHEN 2N146 TRANSISTORS ARE USED THEY WILL BE IN BOTH 1ST. AND 2ND. I.F. STAGES. WHEN 2N145 AND 2N147 TRANSISTORS ARE USED THE 2N145 SHOULD BE IN 1ST. I.F. STAGE AND THE 2N147 IN 2ND. I.F. STAGE.

NOTE:  
ALL TRANSISTORS MARKED "T.I. TYPE" ARE TEXAS INSTRUMENTS INC. TRANSISTOR NUMBERS.

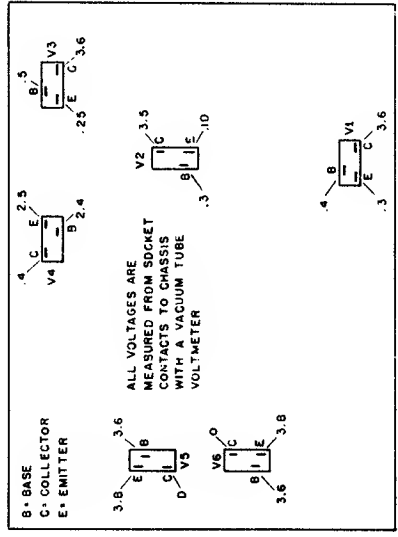
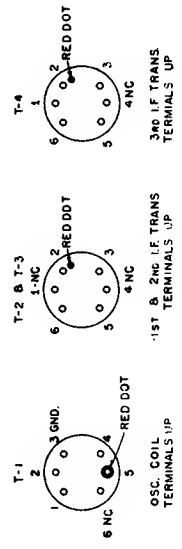

ALL VOLTAGES ARE MEASURED FROM SOCKET CONTACTS TO CHASSIS WITH A VACUUM TUBE VOLTMETER

VOLTAGE TABLE (BOTTOM VIEW OF CHASSIS)

## MAGNAVOX Type AM2 Radio

M O N T G O M E R Y W A R D

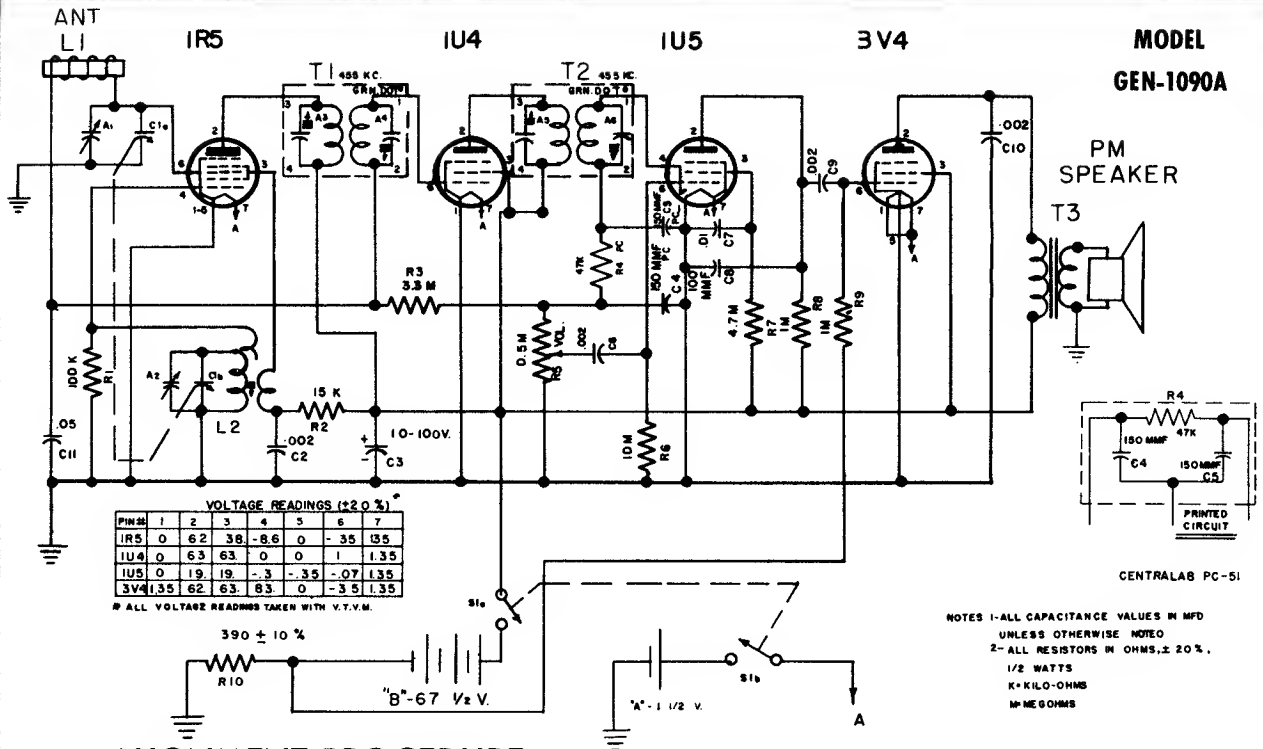

**ALIGNMENT PROCEDURE**

When aligning IF slugs, use a properly shaped, non-metallic tool to avoid stripping the slot in the iron core. The 1 1/2 volt battery should be connected with clip leads to permit easy entry into bottom holes of IF cans.

Always have both batteries in their proper positions when aligning the R.F. section, oscillator, and antonno trimmers. To compensate for front cabinet trim, be sure to have a piece of metal or foil in some position as trim, with respect to chassis during R.F., oscillator, and antenna olignment. Mistracking will result if this is not observed.

**TO ALIGN 1640 KC OSCILLATOR AND 1400 KC ANTENNA TRIMMERS:** Couple test oscillator to receiver by; (1) make loop consisting of five turns of No. 20 to 30 size wire, wound on a 2" or 3" form. (2) connect this loop ocross output of test oscillator. (3) place test oscillator loop near radio antenna—but **no closer than 6"** to radio antenna. **BE SURE THAT NEITHER LOOP NOR RADIO MOVES WHILE ALIGNMENT IS BEING MADE.**

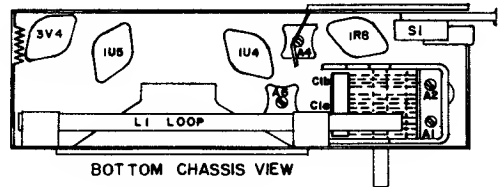
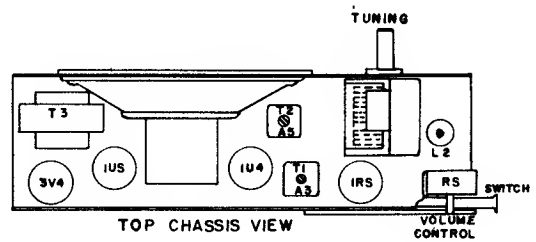

STEPS	SET RECEIVER DIAL TO	TEST OSCILLATOR		REFER TO SCHEMATIC AND LAYOUT FOR LOCATION OF ADJUSTMENTS
		FREQ.	CONNECT OUTPUT	
1	Any point where no interfering signal is received.	455 KC	High side to pin 6 (grid) of 1R5. Low side through a 0.02 MFD condenser to chassis.	Adjust A6, A5, A4, A3 in that order (IF slugs) for maximum output at speaker. Recheck settings after all are completed.
2	Max. clockwise	1640 KC	Test loop (see procedure above)	Adjust A2, (osc. trimmer on gang condenser)
3	1400 KC	1400 KC	Test loop (see procedure above)	Adjust A1, (Antenna trimmer on gang condenser)

MONTGOMERY WARD  
Models GSL-1575A, -B, GSL-1576A, -B

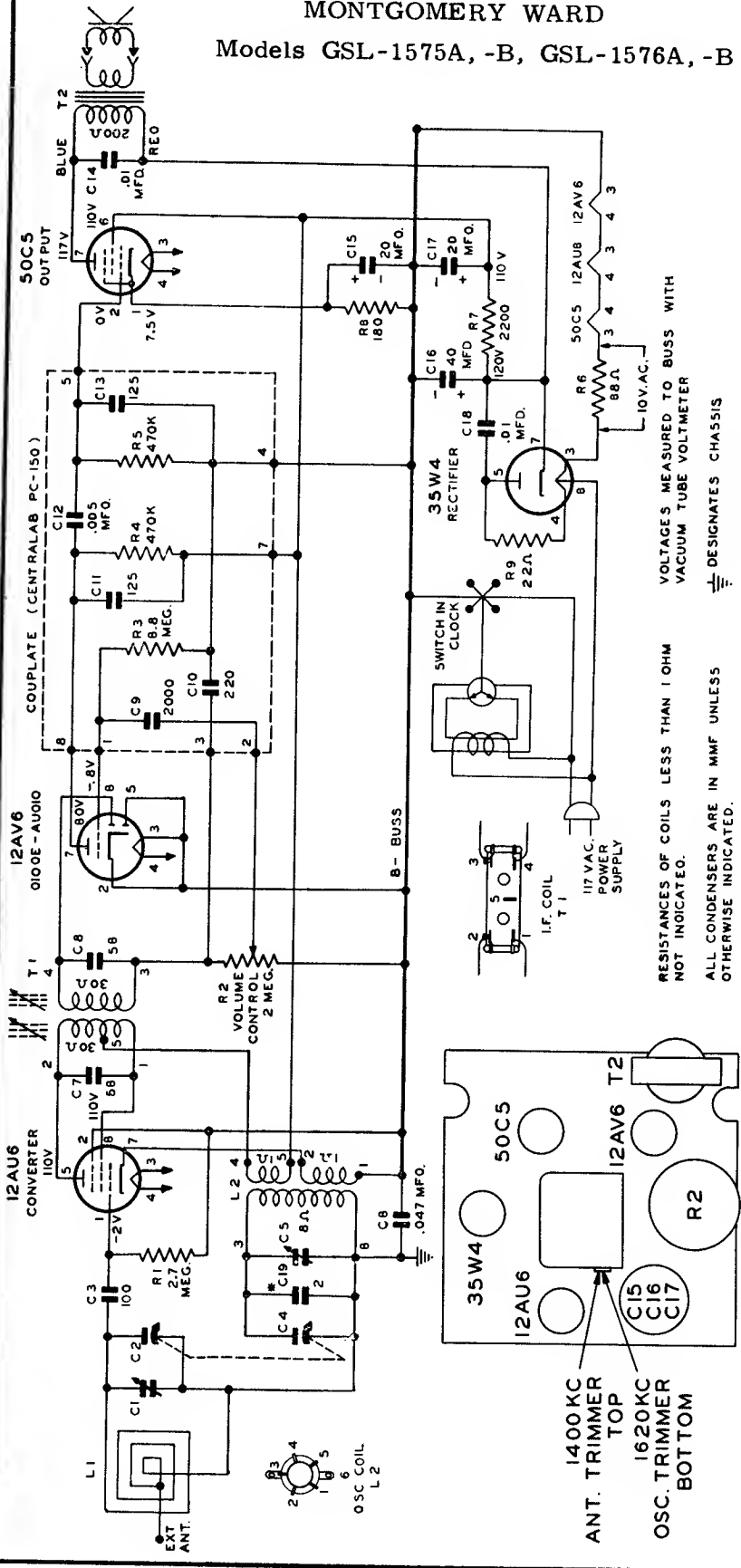

RESISTANCES OF COILS LESS THAN 1 OHM NOT INDICATED.  
ALL CONDENSERS ARE IN MMF UNLESS OTHERWISE INDICATED.  
VOLTAGES MEASURED TO BUSS WITH VACUUM TUBE VOLTMETER  
⊥ DESIGNATES CHASSIS  
\* TC CONDENSER

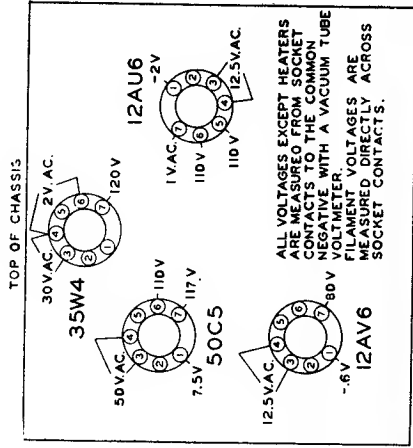

VOLTAGE TABLE

SIGNAL GENERATOR		GROUND CONNECTION	TUNER SETTING	ADJUST FOR MAXIMUM OUTPUT
FREQUENCY	COUPLING CAPACITOR			
455 Kc	.05 Mfd.	B Minus Buss Lead	Any point near center where no interfering signal is received.	Slugs at top of I. F. Coil T-1.
1620 Kc	.05 Mfd.	B Minus Buss Lead	Exactly 1620 Kc.	Oscillator trimmer of Gang. (C5)
1400 Kc	---	B Minus Buss Lead	Exactly 1400 Kc.	Antenna trimmer of Gang. (C1)



# MOTOROLA

MODELS  
76T1 Charcoal  
76T2 Brown

CHASSIS  
HS-507

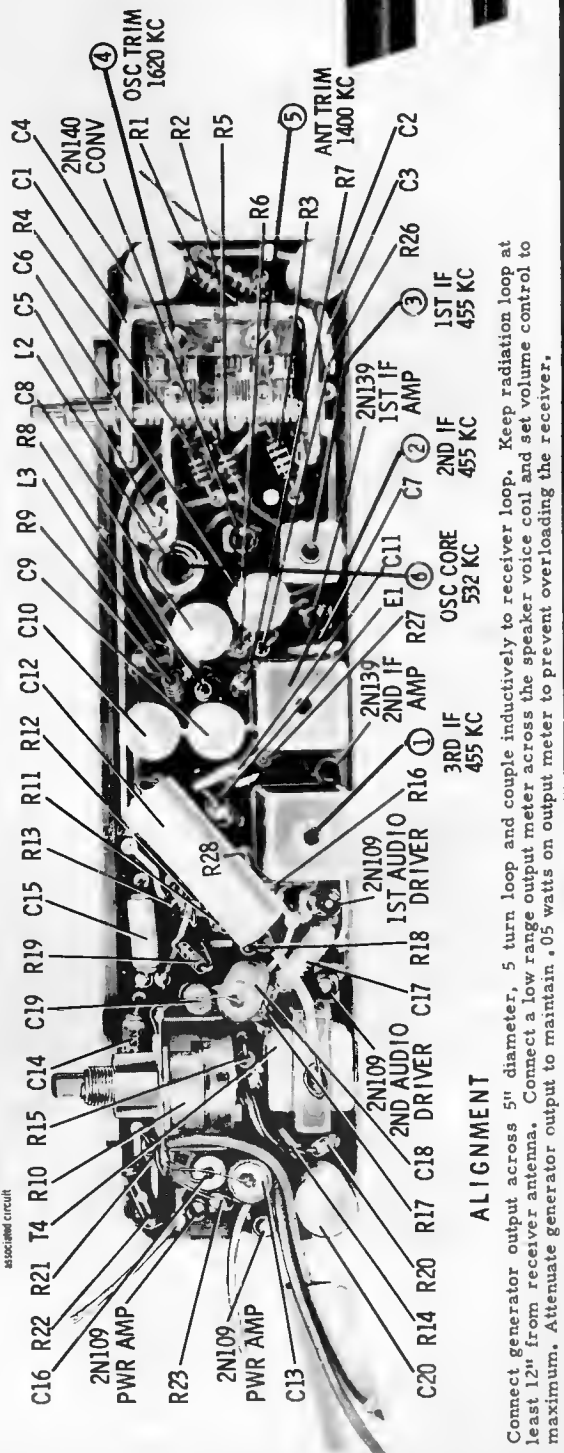
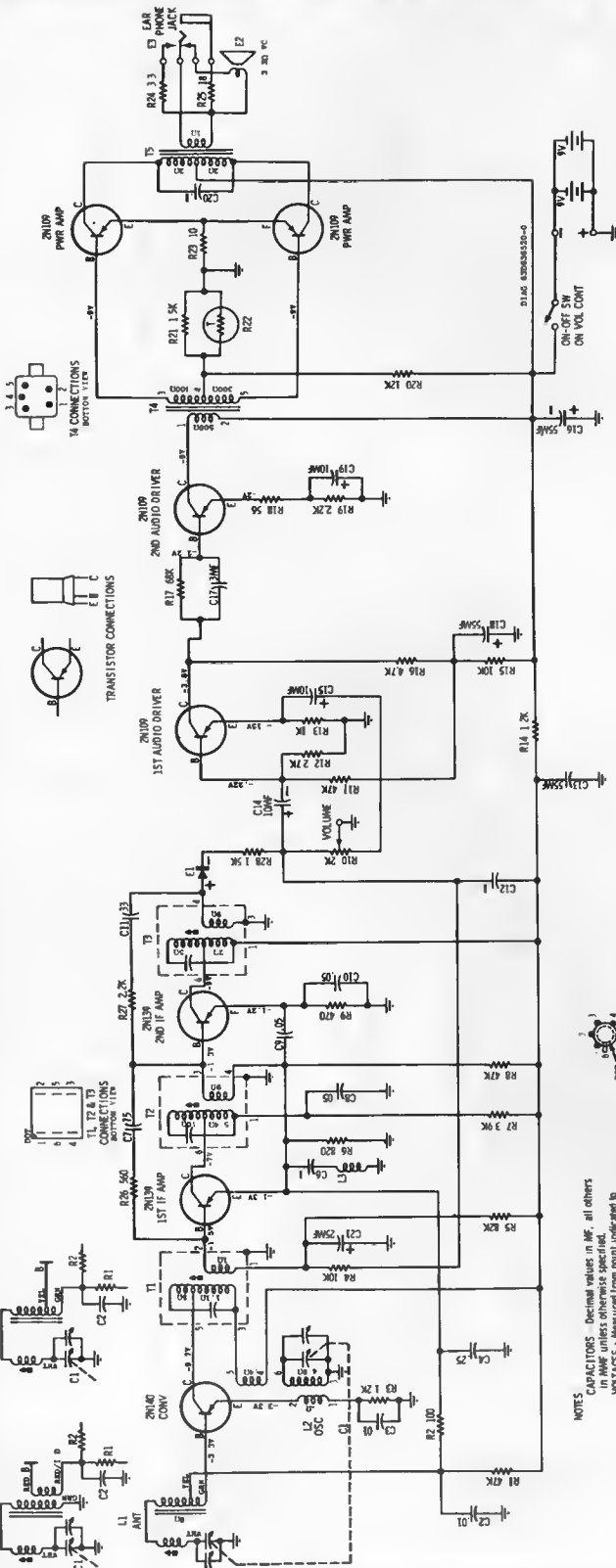
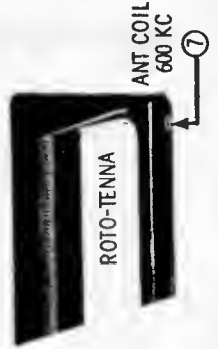

NOTES  
CAPACITORS - Decimal values in  $\mu$ F; all others in MME unless otherwise specified.  
VOLTAGES - Measured from point indicated to ground with a VTR type input, 100  $\mu$  max. impedance.  
RESISTORS - 500 to 1000 KC.  
IF 455 KC.  
Resistances measured with transistor out of associated circuit.

### ALIGNMENT

Connect generator output across 5" diameter, 5 turn loop and couple inductively to receiver loop. Keep radiation loop at least 12" from receiver antenna. Connect a low range output meter across the speaker voice coil and set volume control to maximum. Attenuate generator output to maintain .05 watts on output meter to prevent overloading the receiver.

**MOTOROLA INC.**

Chassis HS-521, Models 57A1, 57A2, 57A3, and  
Chassis HS-522, Models 57R1, 57R2, 57R3, 57R4.

Chassis HS-527 and HS-566, used in Models 57CS1, -A, 57CS2, -A,  
57CS3, -A, 57CS4, -A, are like the above  
chassis plus clock and appliance outlet.

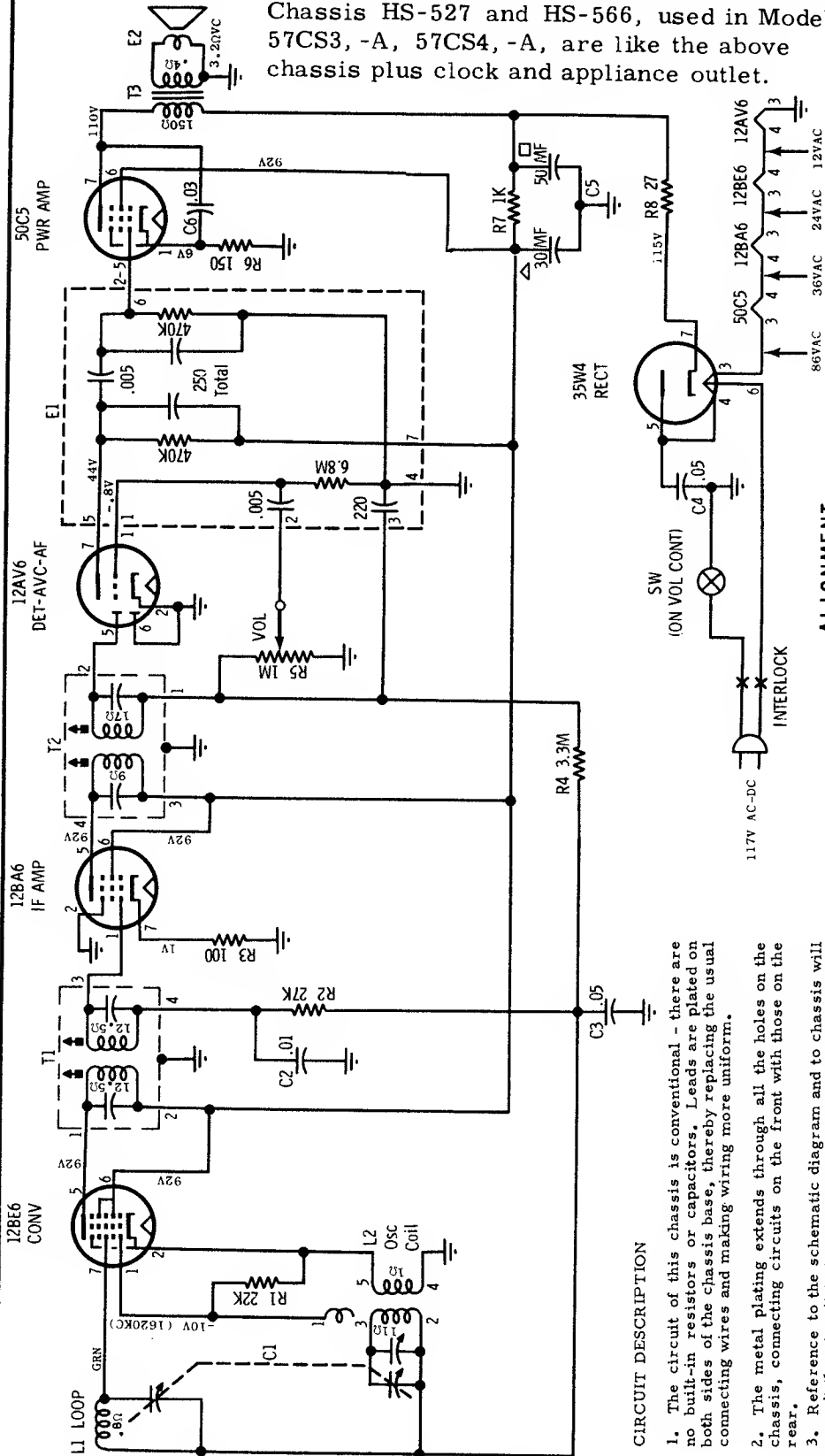

**ALIGNMENT**

Use an isolation transformer between the power line and the receiver. If not available, connect low side of generator to B- through a .1 mf capacitor. Connect a low range output meter across speaker voice coil and set volume control to maximum. Attenuate generator output to maintain .4 volts on output meter to prevent overloading.

STEP	GENERATOR CONNECTION	GENERATOR FREQUENCY (400 cycle mod)	GANG SETTING	ADJUST	REMARKS
IF ALIGNMENT 1.	Grid of conv (pin 7, 12BE6) thru .1 mf & B-	455 Kc	Fully open	T1 and T2 Top and Bottom	Adjust for maximum.
RF ALIGNMENT 2.	Grid of conv (pin 7, 12BE6) thru .1 mf & B-	1620 Kc	Fully open	C1, OSC TRIMMER	Adjust for maximum.

**CIRCUIT DESCRIPTION**

1. The circuit of this chassis is conventional - there are no built-in resistors or capacitors. Leads are plated on both sides of the chassis base, thereby replacing the usual connecting wires and making wiring more uniform.
2. The metal plating extends through all the holes on the chassis, connecting circuits on the front with those on the rear.
3. Reference to the schematic diagram and to chassis will permit the circuit to be traced easily.

Capacitors - Decimal values in MF, all others in MMF unless otherwise specified.

Volts - Measured from point indicated to ground with a VTVM. No signal input.

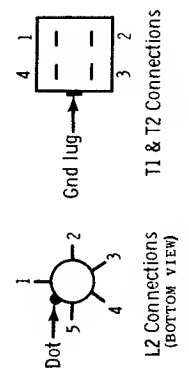

VOLUME R-17, MOST-OFTEN-NEEDED 1957 RADIO SERVICING INFORMATION

**MOTOROLA INC.** CHASSIS HS-523, HS-565, Models 57H1, 57H2, 57H3, 57H4  
57H1A, 57H2A, 57H3A, 57H4A

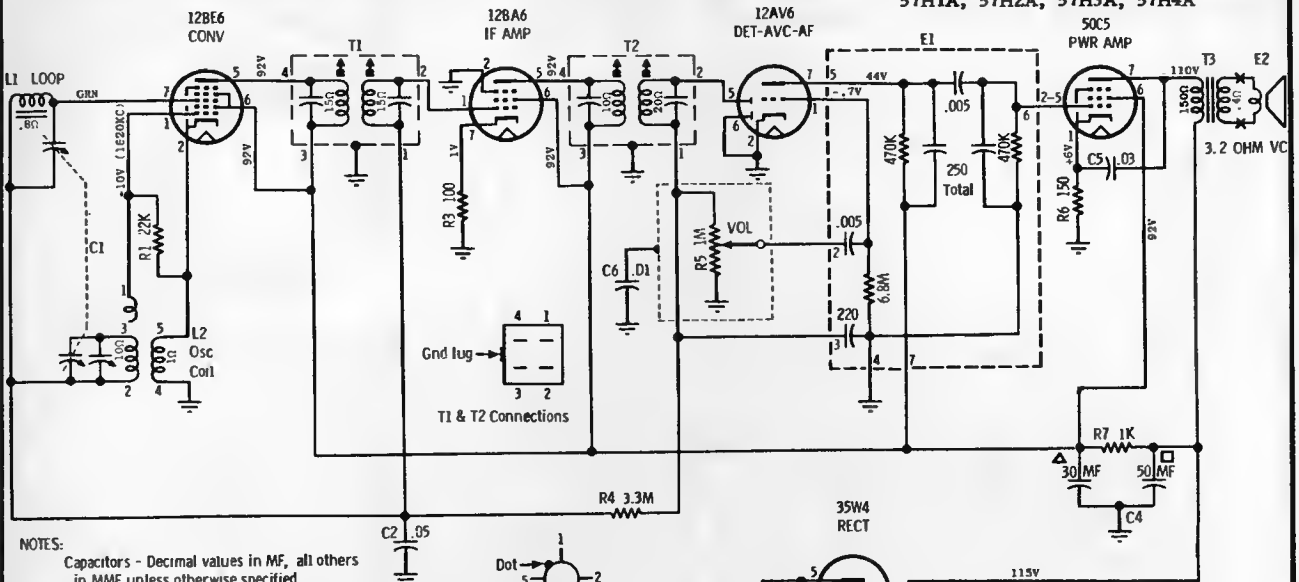

NOTES:

Capacitors - Decimal values in MF, all others in MMF unless otherwise specified.

Voltages - Measured from point indicated to ground with a VTVM. No signal input. Input voltage - 117 AC ± 10%.

Tuning Range - 535 to 1620 KC.  
IF - 455 KC.

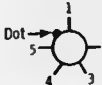

L2 Connections

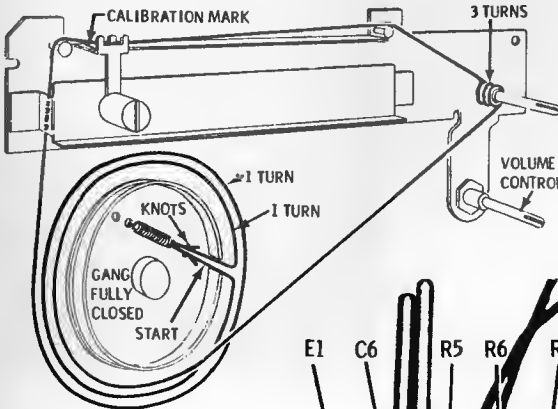
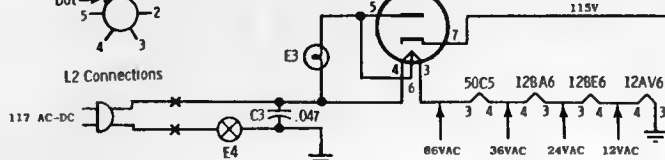

DIAL STRINGING

DISASSEMBLY INSTRUCTIONS

1. Pry rear cover off with a small screwdriver by inserting screwdriver between cabinet and top center edge of cover. Care should be taken not to damage cabinet with screwdriver.
2. Pull knobs off from front of receiver.
3. Compress mounting bracket and slide ON-OFF switch and pilot light assembly from retaining slots in cabinet.
4. Remove screw from interlock plug and remove interlock plug.
5. Remove three screws which hold chassis in cabinet.

- MODELS
- 57H1 Ebony
  - 57H2 White
  - 57H3 Green
  - 57H4 Blue

CHASSIS HS-523

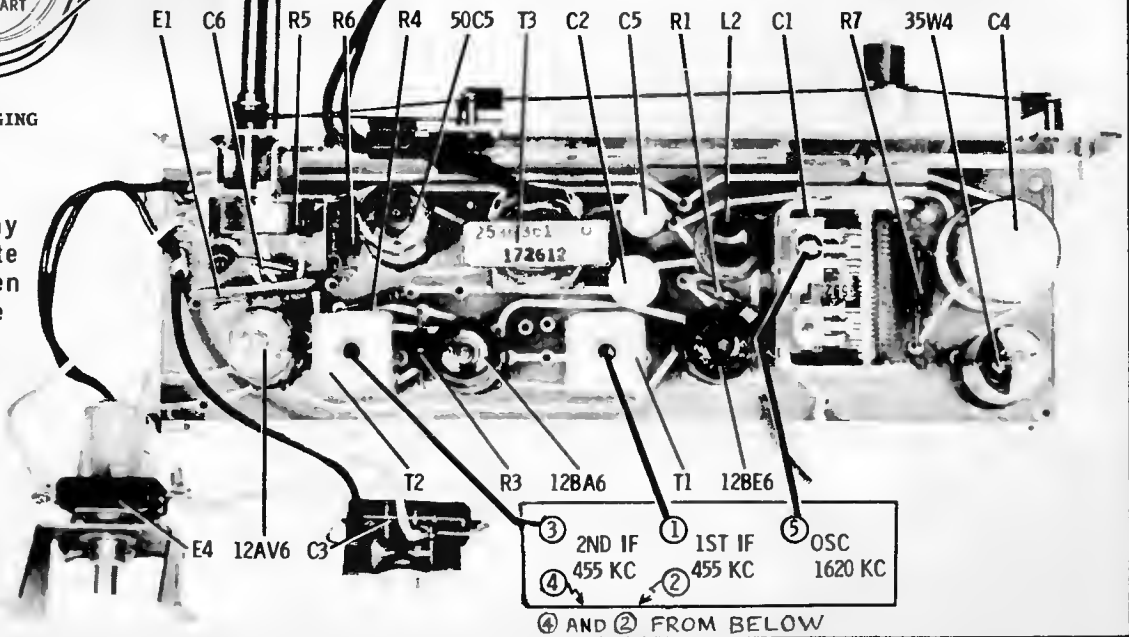

# MOTOROLA

**MODELS**  
 57X1 Green  
 57X2 Ivory

**CHASSIS**  
 HS-524

Chassis HS-525, in Models 57W1, -B, -MC, is the same electrically plus phono input and pilot light.

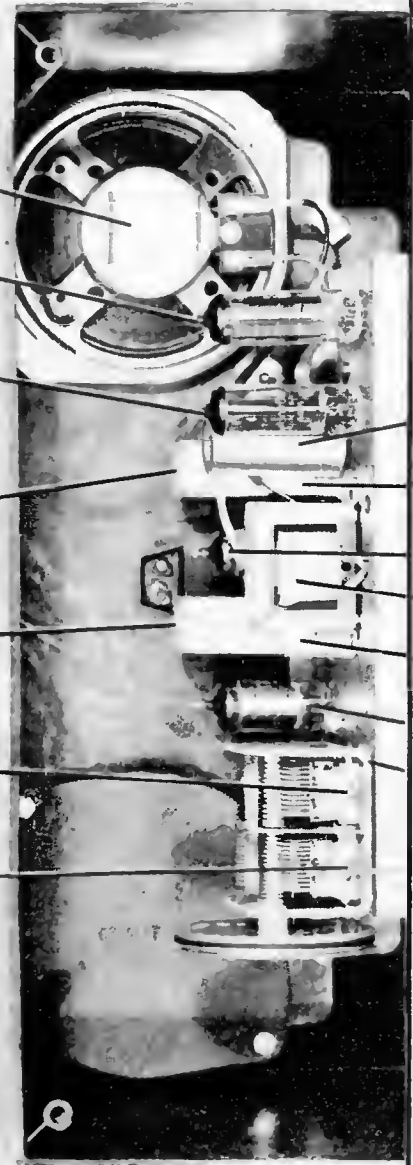
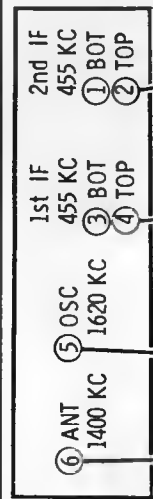
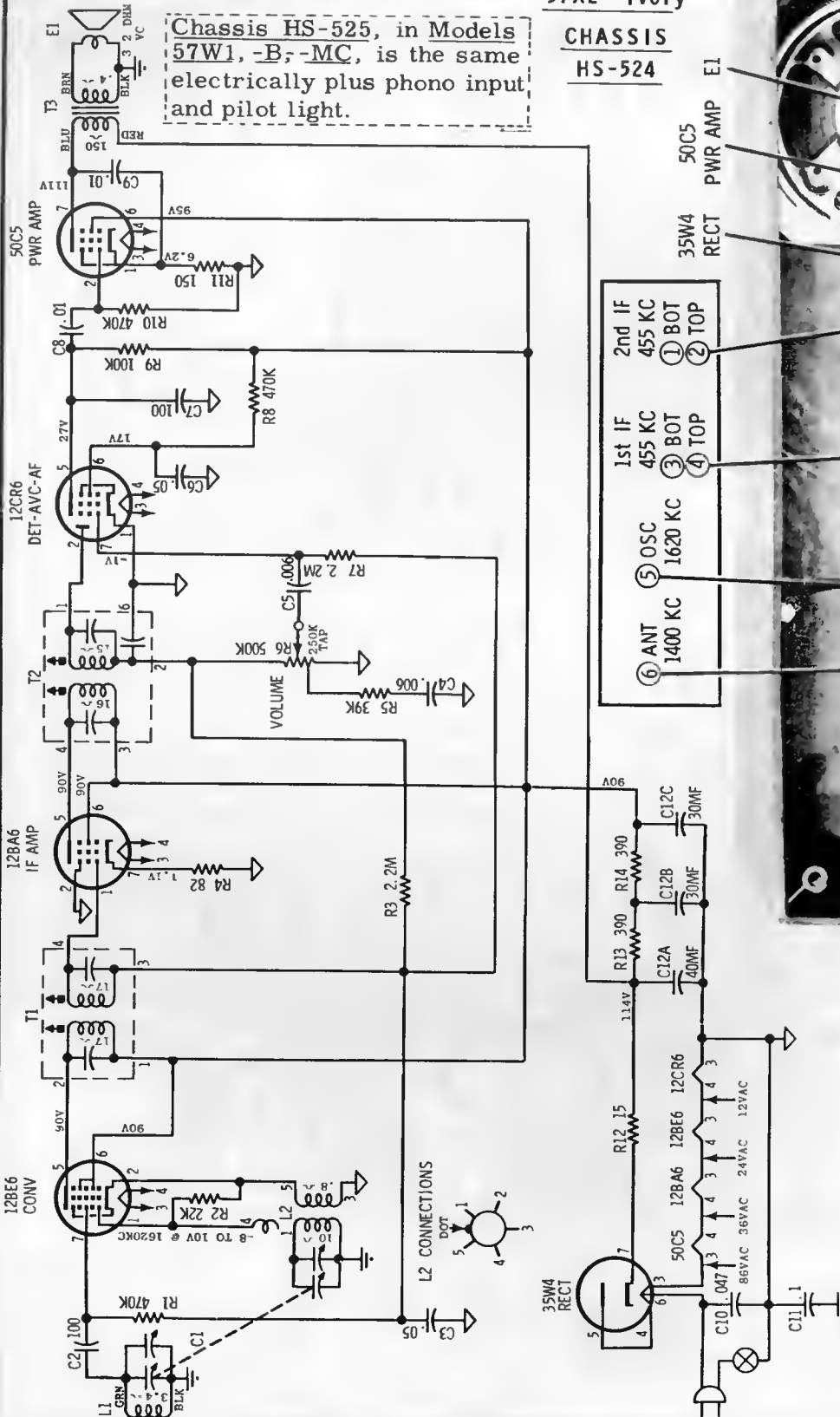

**NOTES:**  
 Capacitors - decimal values in MF, all others in MMF unless otherwise specified.  
 Voltages - measured from point indicated to B- with a VTVM. No signal input.  $\nabla$  - B-  
 Tuning range - 550 to 1620Kc. IF - 455 Kc.

# MOTOROLA

**MODELS**

67X1 Mahogany  
67X2 Ivory

**CHASSIS**

HS-526

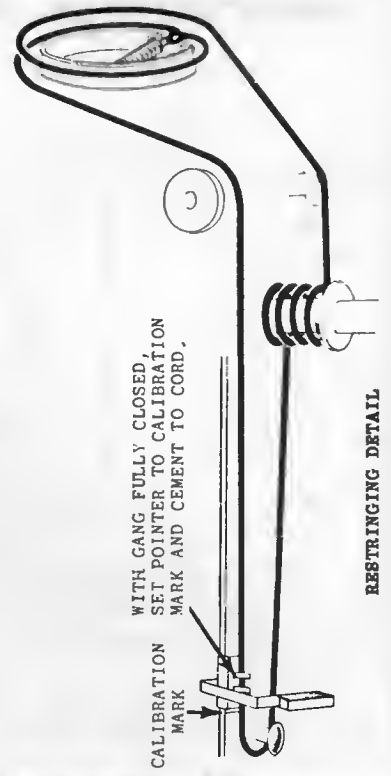
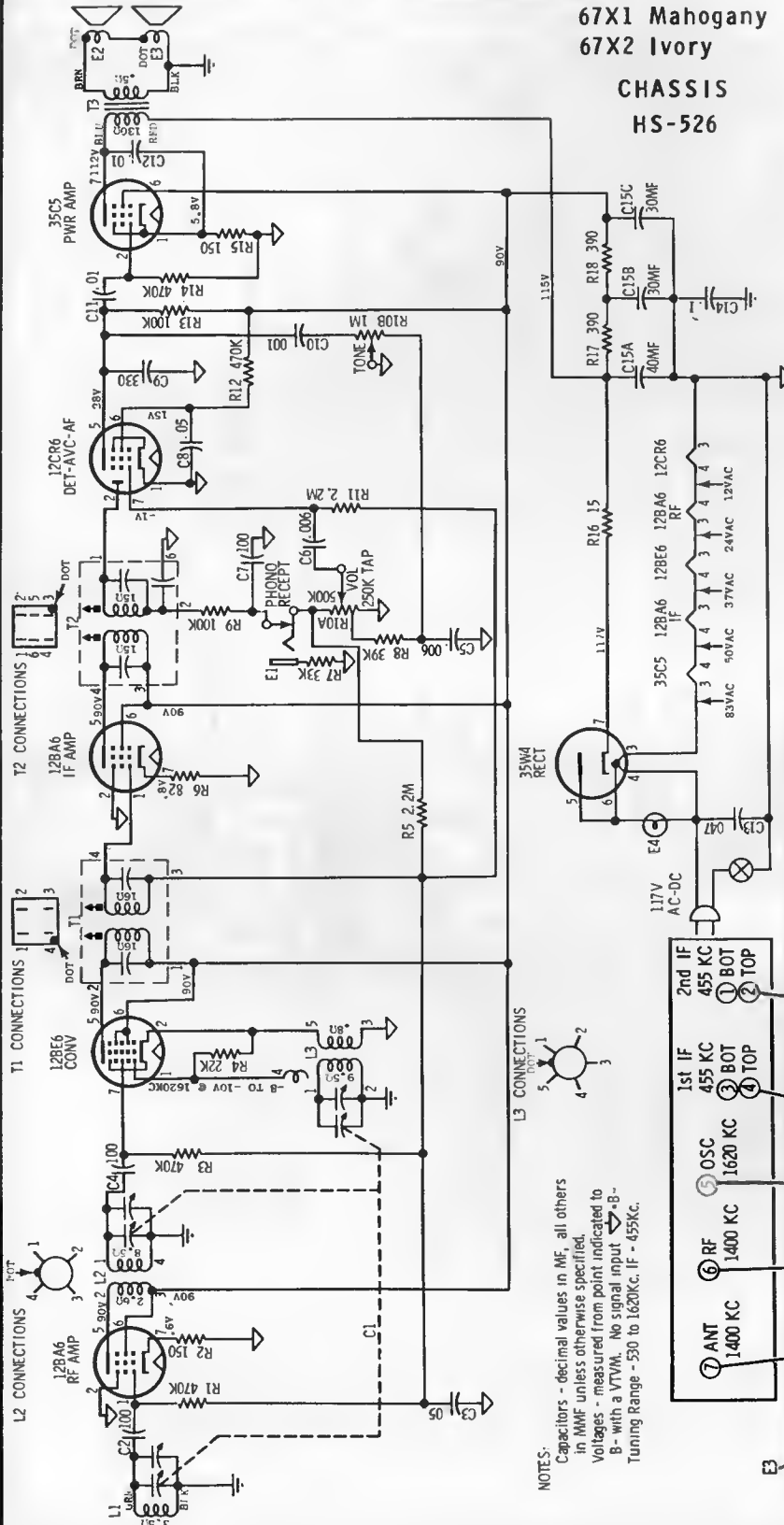

WITH GANG FULLY CLOSED, SET POINTER TO CALIBRATION MARK AND CEMENT TO CORD.



**NOTES:**  
Capacitors - decimal values in MF, all others in MMF unless otherwise specified.  
Voltages - measured from point indicated to B- with a VTVM. No signal input  $\nabla$ -B-  
Tuning Range - 530 to 1620Kc. IF - 455Kc.

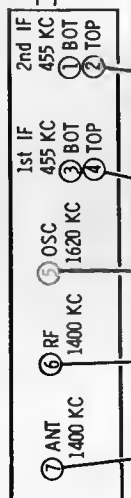

**MOTOROLA INC.**

CHASSIS  
HS-528 HS-567

MODELS

57CD1  
57CD2

57CD1A  
57CD2A

Mahogany  
White

57CD3  
57CD4

57CD3A  
57CD4A

Blue  
Turquoise

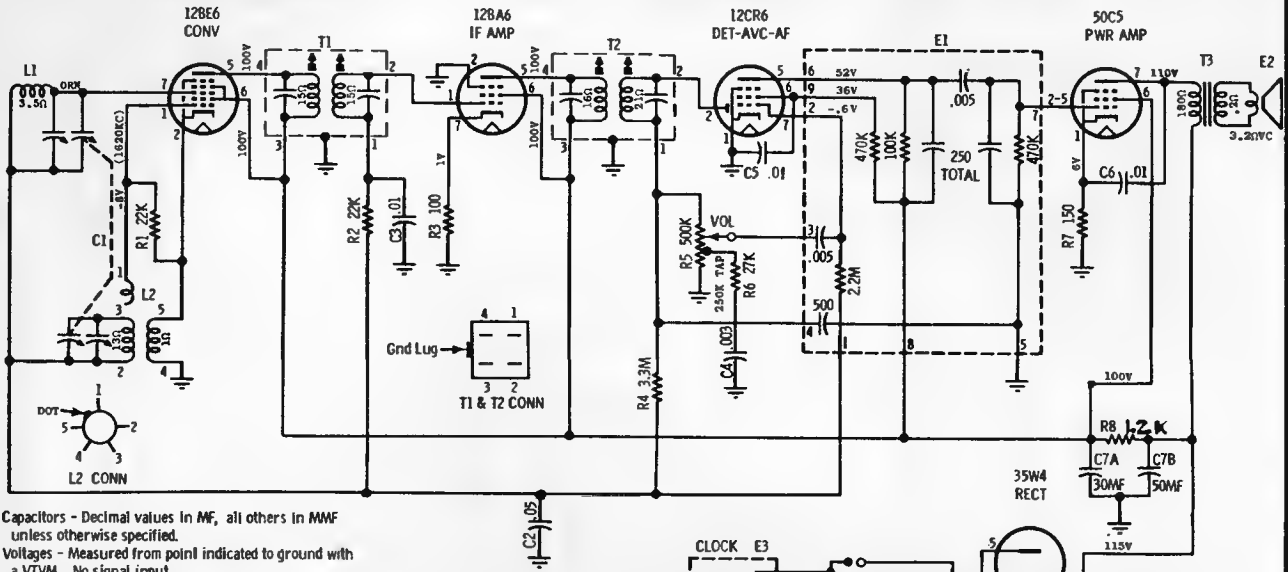

Capacitors - Decimal values in MF, all others in MMF unless otherwise specified.  
Voltages - Measured from point indicated to ground with a VTVM. No signal input.  
Tuning Range - 535 to 1620 KC.

A 390 10% 1/2 watt Allen Bradley type resistor (R9) has been added to the 12CR6 tube; this resistor is wired across the filament of the 12CR6 (between pins 3 & 4) to stabilize filament voltage during warm-up time.

To Remove Chassis From Cabinet

1. From front of cabinet, pull off the two control knobs and the dial scale knob.
2. Remove the screws which hold the cabinet back in place and remove the cabinet back.
3. From rear of cabinet, unplug the chassis AC connecting leads and the appliance outlet leads.
4. From rear of cabinet, unsolder the output transformer leads from the output transformer which is mounted on the speaker.
5. From rear of cabinet, remove the two chassis mounting screws.

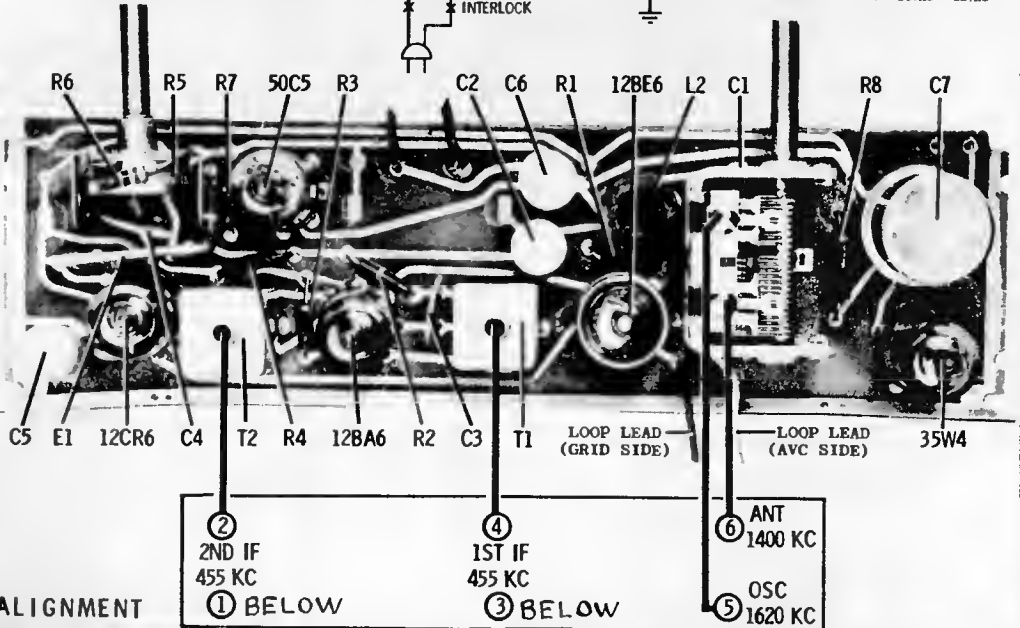

ALIGNMENT

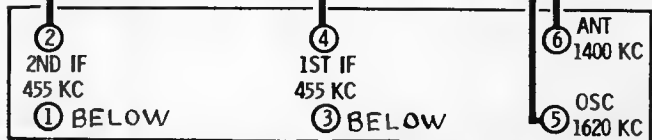

STEP	GENERATOR CONNECTION	GENERATOR FREQUENCY (400 cycle mod)	GANG SETTING	ADJUST	REMARKS
<b>IF ALIGNMENT</b>					
1.	Grid of conv (pin 7, 12BE6) thru .1 mf & B-	455 Kc	Fully open	1, 2, 3 & 4	Adjust for maximum.
<b>RF ALIGNMENT</b>					
2.	Grid of conv (pin 7, 12BE6) thru .1 mf & B-	1620 Kc	Fully open	5	Adjust for maximum.
3.	Radiation loop*	1400 Kc	Tune for max	6	Adjust for maximum.

\*Connect generator output across 5" diameter, 5-turn loop and couple inductively to receiver loop. Keep loops at least 12" apart.

# MOTOROLA

CHASSIS  
HS-529

MODELS  
67C1 Mahogany  
67C2 Sand

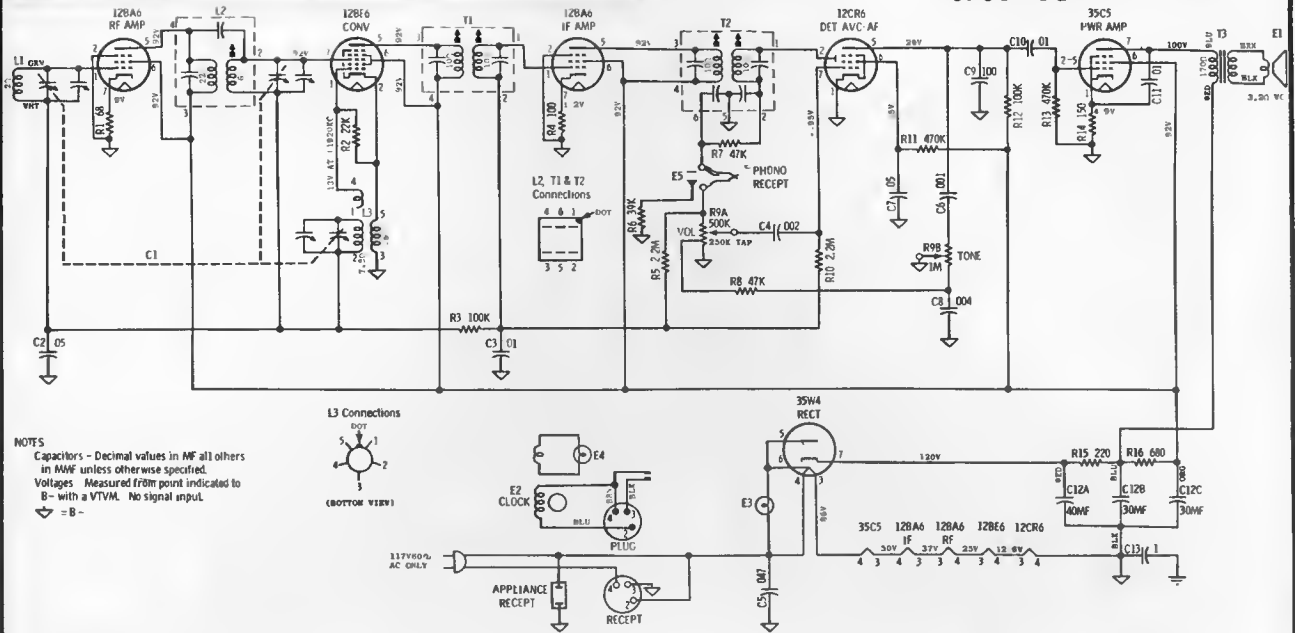

**NOTES**  
Capacitors - Decimal values in MF all others in MMF unless otherwise specified.  
Voltages - Measured from point indicated to B- with a VTVM. No signal input.  
⊖ = B-



**To Remove Chassis from Cabinet**

1. Remove screws which hold the cabinet back cover and remove the cover.
2. Pull off the three control knobs from the front of the receiver.
3. Unplug the antenna, clock and speaker leads from their respective sockets.
4. Remove three screws from the bottom of chassis.
5. Remove radio from cabinet.

ALIGNMENT ADJUSTMENTS & PARTS LOCATION

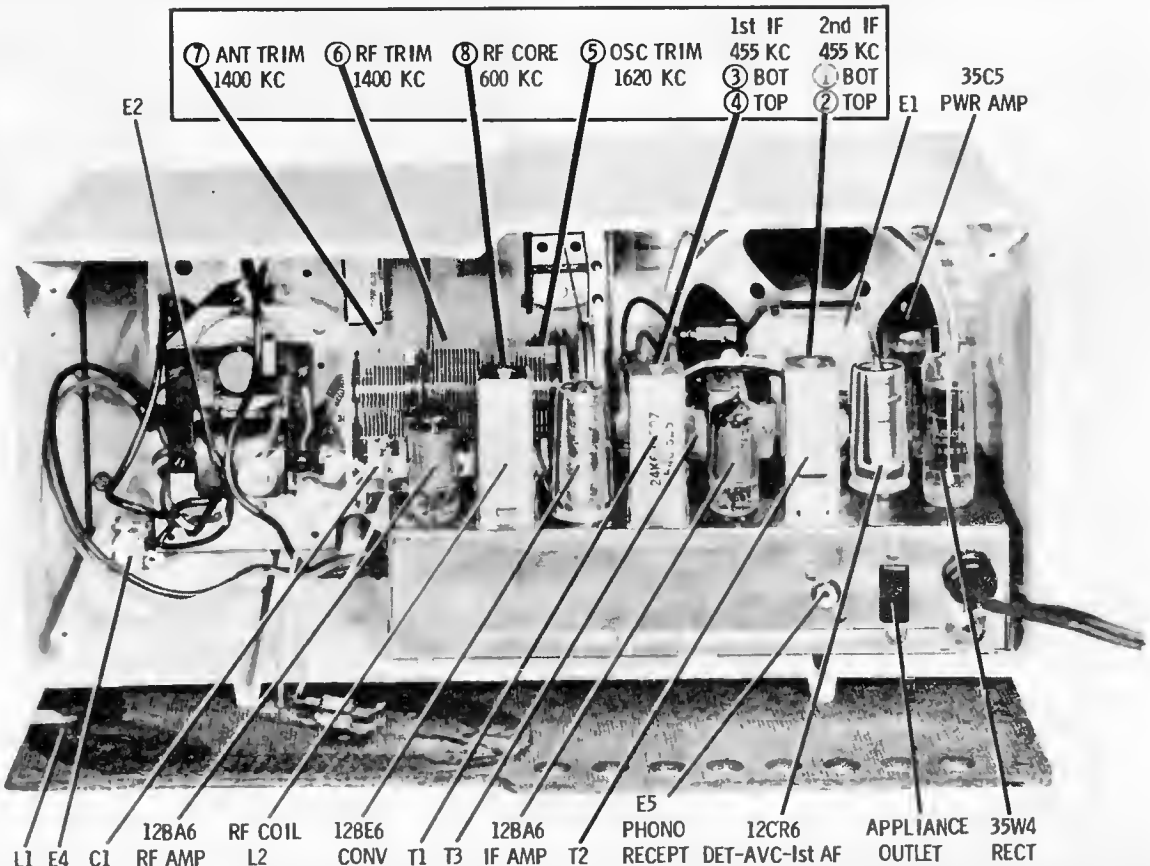

**MOTOROLA**

**CHASSIS MODELS**  
 HS-530 57CE  
 57CE1  
 57CE2  
 57CF1  
 57CF2

To Remove Chassis

1. Remove cabinet back cover screws and remove cover.
2. Pull off the two control knobs from the front of the radio.
3. From front, remove the Phillips head screw near tuning shaft.
4. From rear, remove chassis mounting screw from the ear of the volume control.
5. Unplug power leads from connector strip located behind clock.
6. Remove chassis from cabinet.

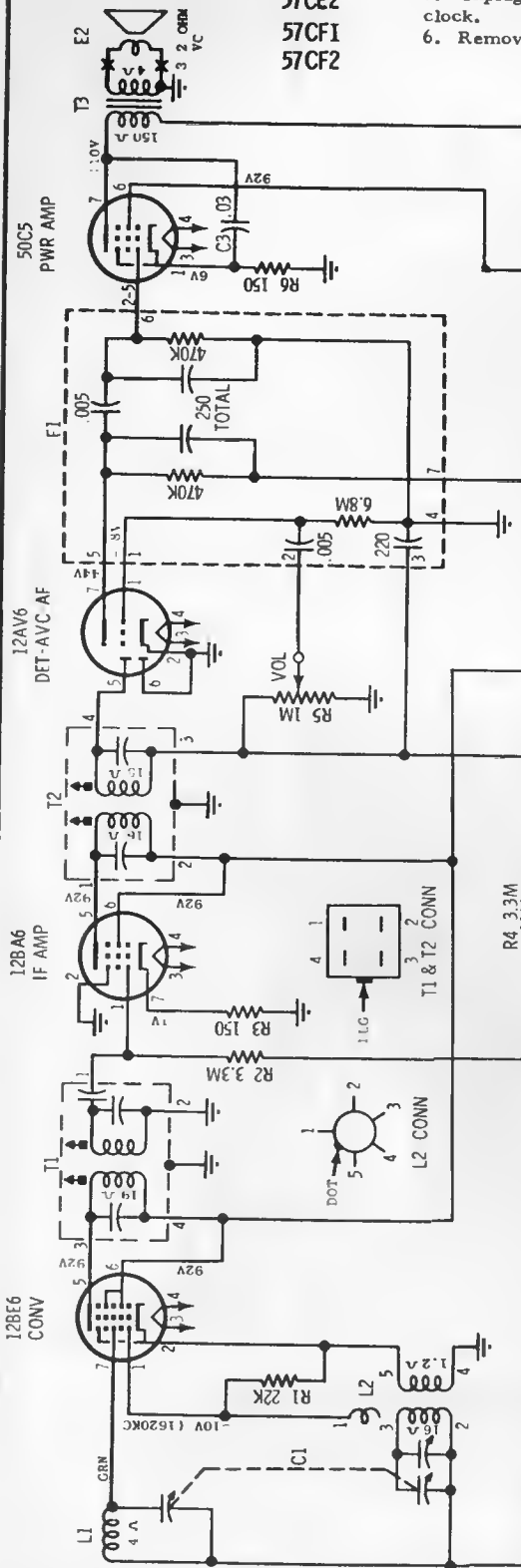

**NOTES:**  
 Capacitors - Decimal values in MF, all others in MMF unless otherwise specified.  
 Voltages - Measured from point indicated to ground with a VTVM. No signal input.  
 Tuning Range - 535 to 1620 KC.

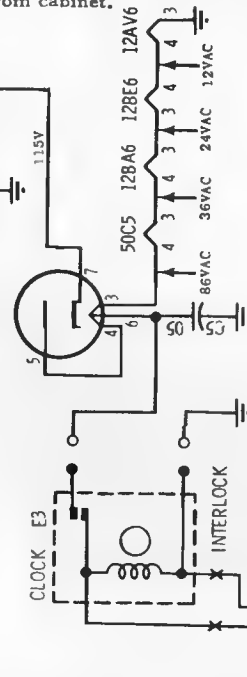

**ALIGNMENT**

STEP	GENERATOR CONNECTION	GENERATOR FREQUENCY (400 cycle mod)	GANG SETTING	ADJUST
IF ALIGNMENT	Grid of conv (pin 7, 12BE6) thru .1 mf & B-	455 Kc	Fully open	1, 2, 3 & 4 for maximum.
RF ALIGNMENT	Grid of conv (pin 7, 12BE6) thru .1 mf & B	1620 Kc	Fully open	5 for maximum.

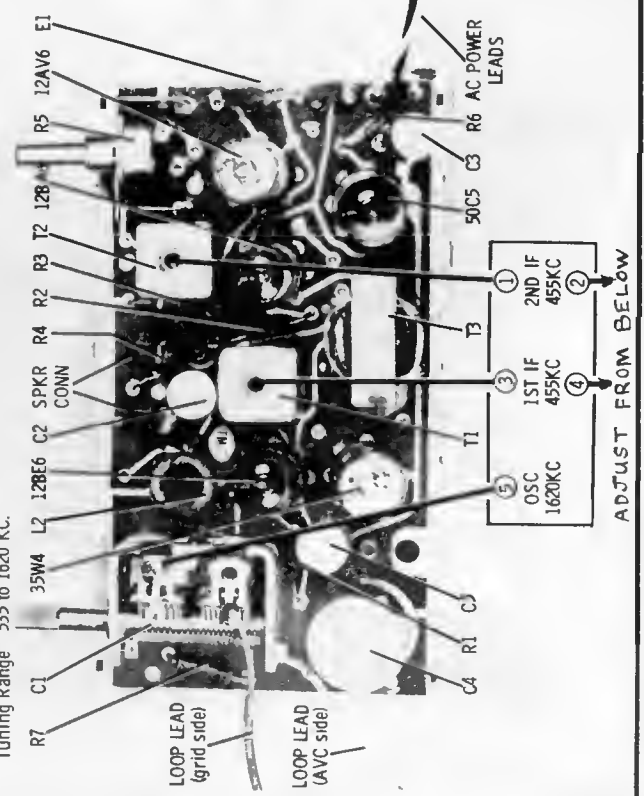



# MOTOROLA

CHASSIS  
HS-531

MODELS  
57CC1 Turquoise  
57CC2 Pink

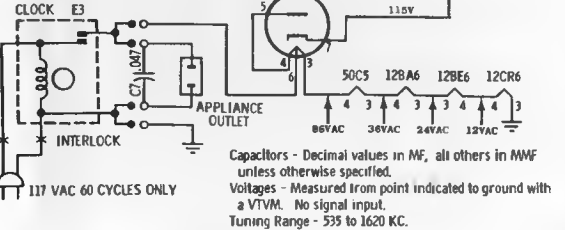
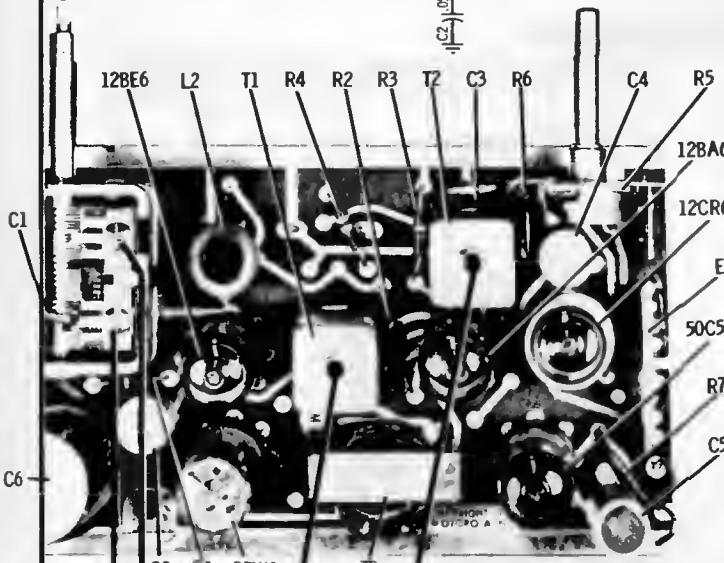
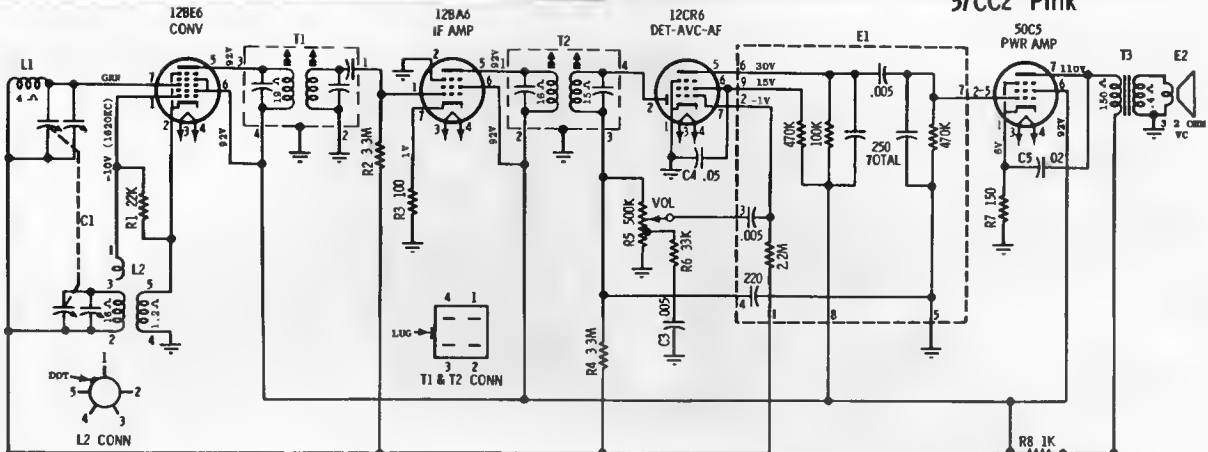

Capacitors - Decimal values in MF, all others in MMF unless otherwise specified.  
Voltages - Measured from point indicated to ground with a VTVM. No signal input.  
Tuning Range - 535 to 1620 KC.

**To Remove Chassis from Cabinet**

1. Remove two screws which hold the cabinet back in place and remove the cabinet back.
2. From front of cabinet, pull off two control knobs and pointer.
3. From under pointer, remove one chassis screw.
4. From rear of cabinet, remove one chassis screw from volume control ear.
5. Pull off the chassis AC leads to the AC connector terminal strip.

**To Remove Clock from Cabinet**

1. Remove two screws which hold the cabinet back in place and remove the cabinet back.
2. Pull three knobs off front of clock.
3. From rear of cabinet, remove four screws which hold clock in place and remove clock.

ADJUST FROM BELOW

**ALIGNMENT**

Use an isolation transformer between the power line and the receiver. Connect low side of generator to B- (outer chassis edges) through a .1 mf capacitor. Temporarily connect the speaker and AC leads. Connect a low range output meter across the speaker voice coil and set volume control to maximum. Attenuate generator output to maintain .40 volts on output meter to prevent overloading.

STEP	GENERATOR CONNECTION	GENERATOR FREQUENCY (400 cycle mod)	GANG SETTING	ADJUST	REMARKS
<b>IF ALIGNMENT</b>					
1.	Grid of conv (pin 7, 12BE6) thru .1 mf & B-	455 Kc	Fully open	1, 2, 3 & 4	Adjust for maximum.
<b>RF ALIGNMENT</b>					
2.	Grid of conv (pin 7, 12BE6) thru .1 mf & B-	1620 Kc	Fully open	5	Adjust for maximum.
3.	Radiation loop*	1400 Kc	Tune for max	6	Adjust for maximum.

\*Connect generator output across 5" diameter, 5-turn loop and couple inductively to receiver loop. Keep loops at least 12" apart.

# MOTOROLA

CHASSIS MODEL  
HS-556 66T1

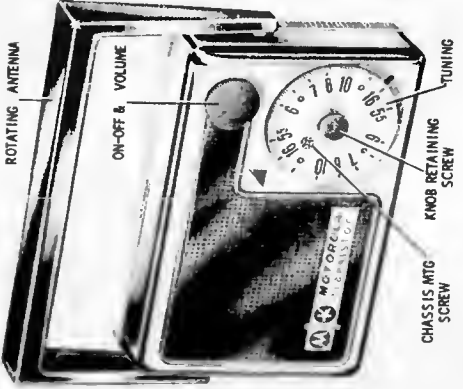
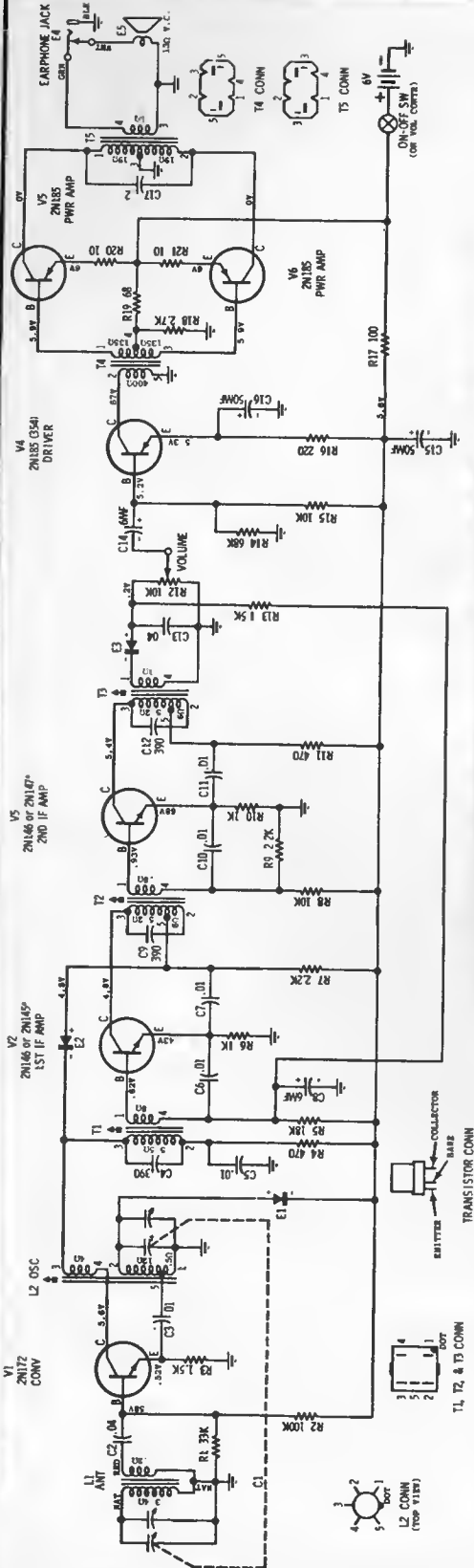

**CHASSIS REMOVAL**

1. Pull the volume control knob from front of radio.
2. Remove tuning knob retaining screw from the tuning knob and remove the tuning knob (see cover photo).
3. Remove chassis mounting screw from under tuning knob (see cover photo).
4. Open rear cover and turn handle perpendicular to the plated chassis.

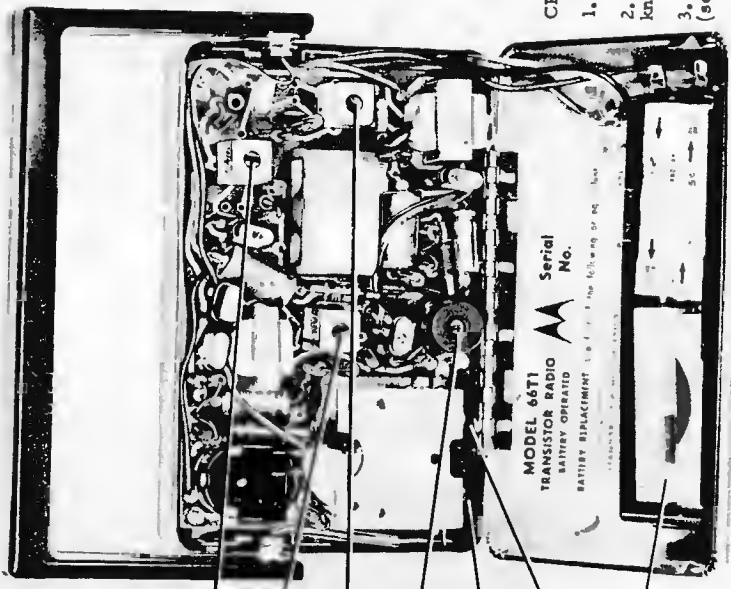

2ND IF	455 KC
1ST IF	455 KC
3RD IF	455 KC
OSC CORE	530 KC
ANT TRIM	1400 KC
OSC TRIM	1620 KC

**BATTERIES**

**ALIGNMENT ADJUSTMENTS LOCATION**

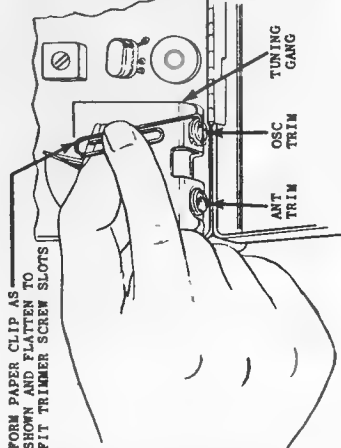

**GANG TRIMMER ADJUSTMENT TOOL DETAIL**

**NOTES:**

CAPACITORS - Decimal values in MF, others in MMF unless otherwise specified.

VOLTAGES - Measured from point indicated to ground with a VTVM. No signal input, volume at maximum, tuning range - 50 KC to 1620 KC. IF - 455 KC.

\*Use either a pair of 2N146's for the 1ST and 2ND IF amplifiers or a 2N145 for the 1ST IF AMP and a 2N147 for the 2ND IF AMP. Use no other components.

RESISTANCES - Measured with the transistors out of associated circuits.

FORM PAPER CLIP AS SHOWN AND FLATTEN TO FIT TRIMMER SCREW SLOTS

**MOTOROLA INC.**

CHASSIS  
HS-540

MODELS  
27F1 Red & Tweed  
27F2 Two Tone Blue

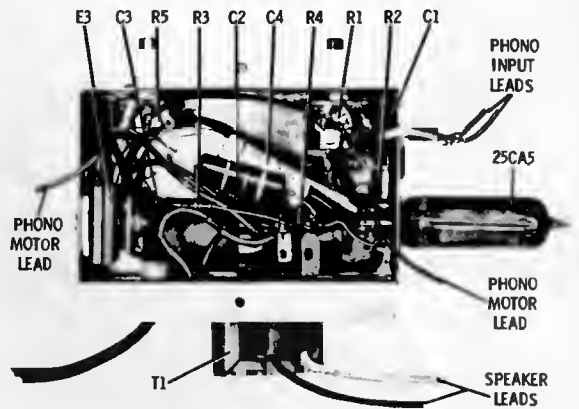
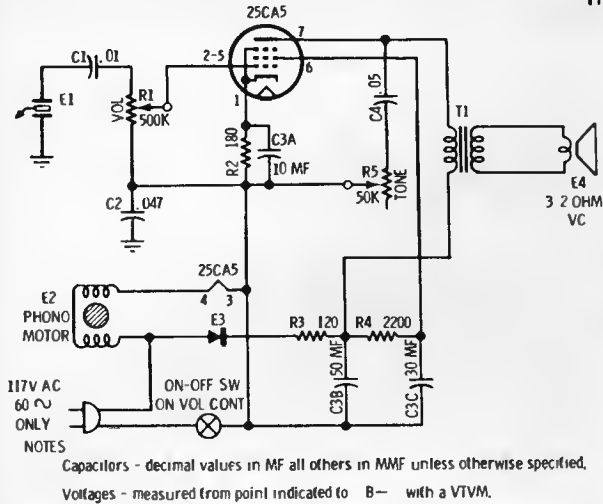

**PARTS LOCATIONS**

To Remove Chassis from Cabinet

1. Pull off two knobs from front of cabinet.
2. Remove screws which mount baffle and remove baffle.
3. Remove four screws from corners of phono mounting board.
4. Remove mounting board from cabinet.
5. Remove two screws which hold chassis to mounting board and remove chassis.

**MOTOROLA INC.**

MODEL  
37F1 Gray & Pink  
37F2 Green & Black

CHASSIS  
HS-541

12AV6  
VOLTAGE AMP

50C5  
PWR AMP

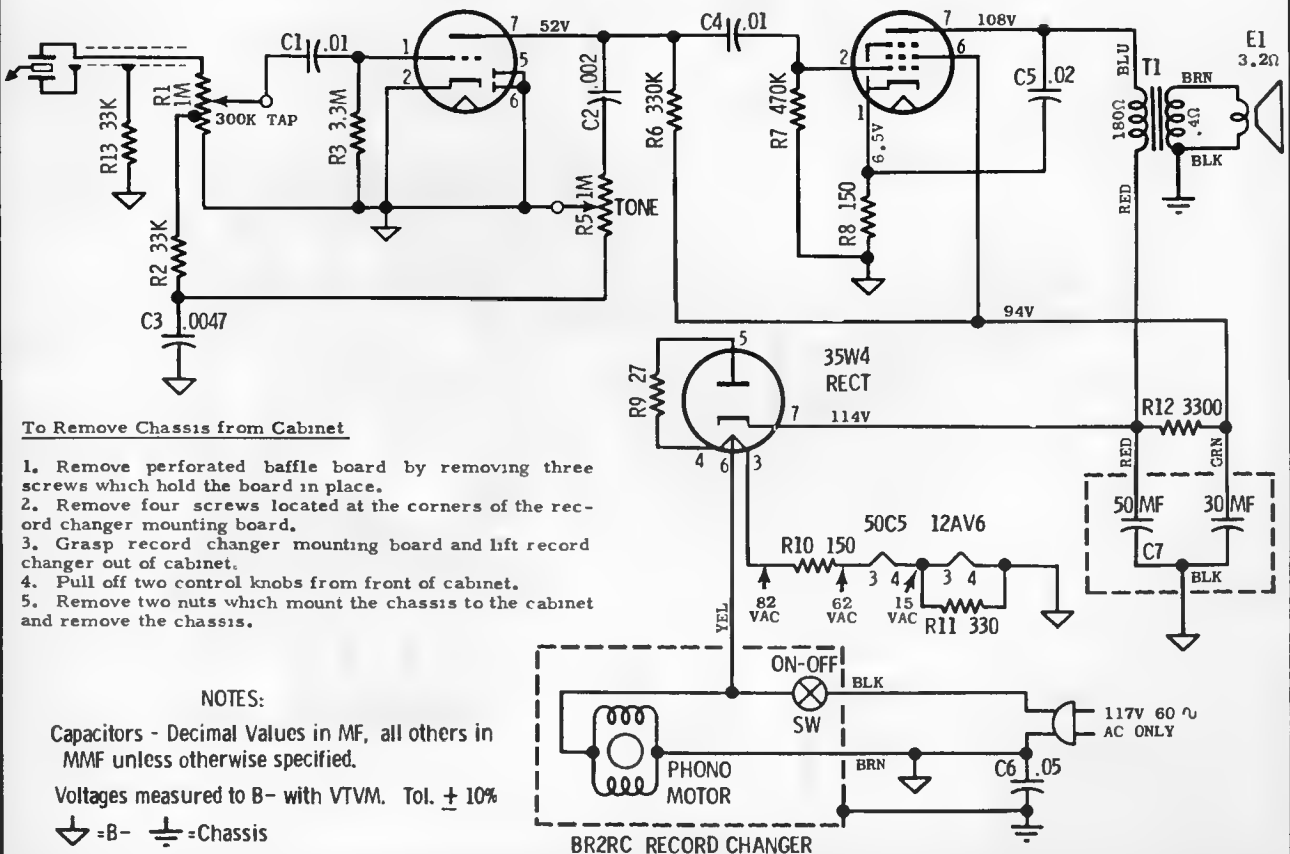

**MOTOROLA INC.**

MODEL  
57RF1 Two Tone Blue  
57RF2 Copper & White

CHASSIS  
HS-542

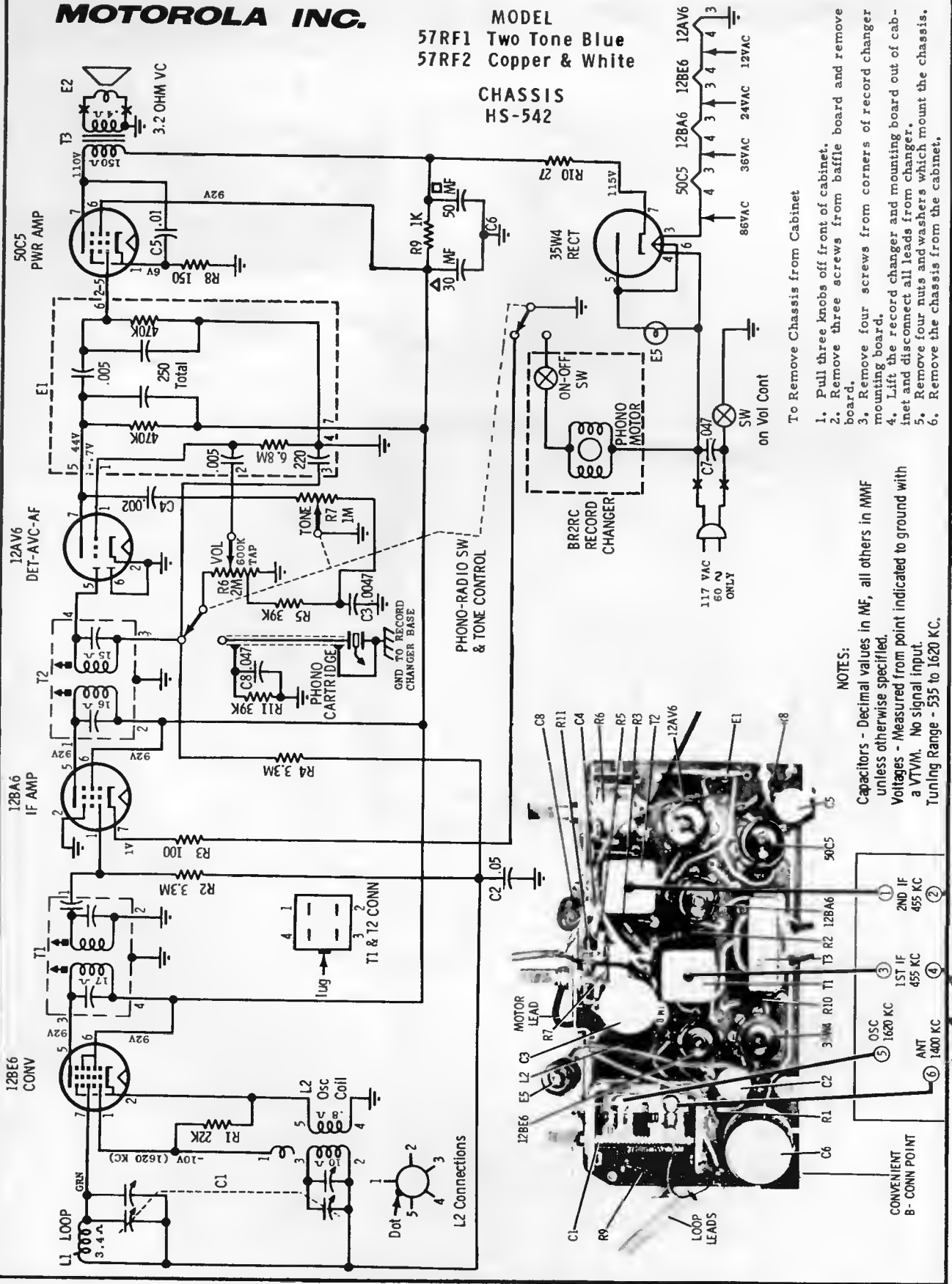

To Remove Chassis from Cabinet

1. Pull three knobs off front of cabinet.
2. Remove three screws from baffle board and remove board.
3. Remove four screws from corners of record changer mounting board.
4. Lift the record changer and mounting board out of cabinet and disconnect all leads from changer.
5. Remove four nuts and washers which mount the chassis.
6. Remove the chassis from the cabinet.

NOTES:

Capacitors - Decimal values in MF, all others in MMF unless otherwise specified.  
 Voltages - Measured from point indicated to ground with a VTVM. No signal input.  
 Tuning Range - 535 to 1620 KC.

ADJUST ④ AND ② FROM BELOW

# MOTOROLA

MODELS  
57HFP1 Tan  
57HFP2 Gray  
CHASSIS  
HS-543

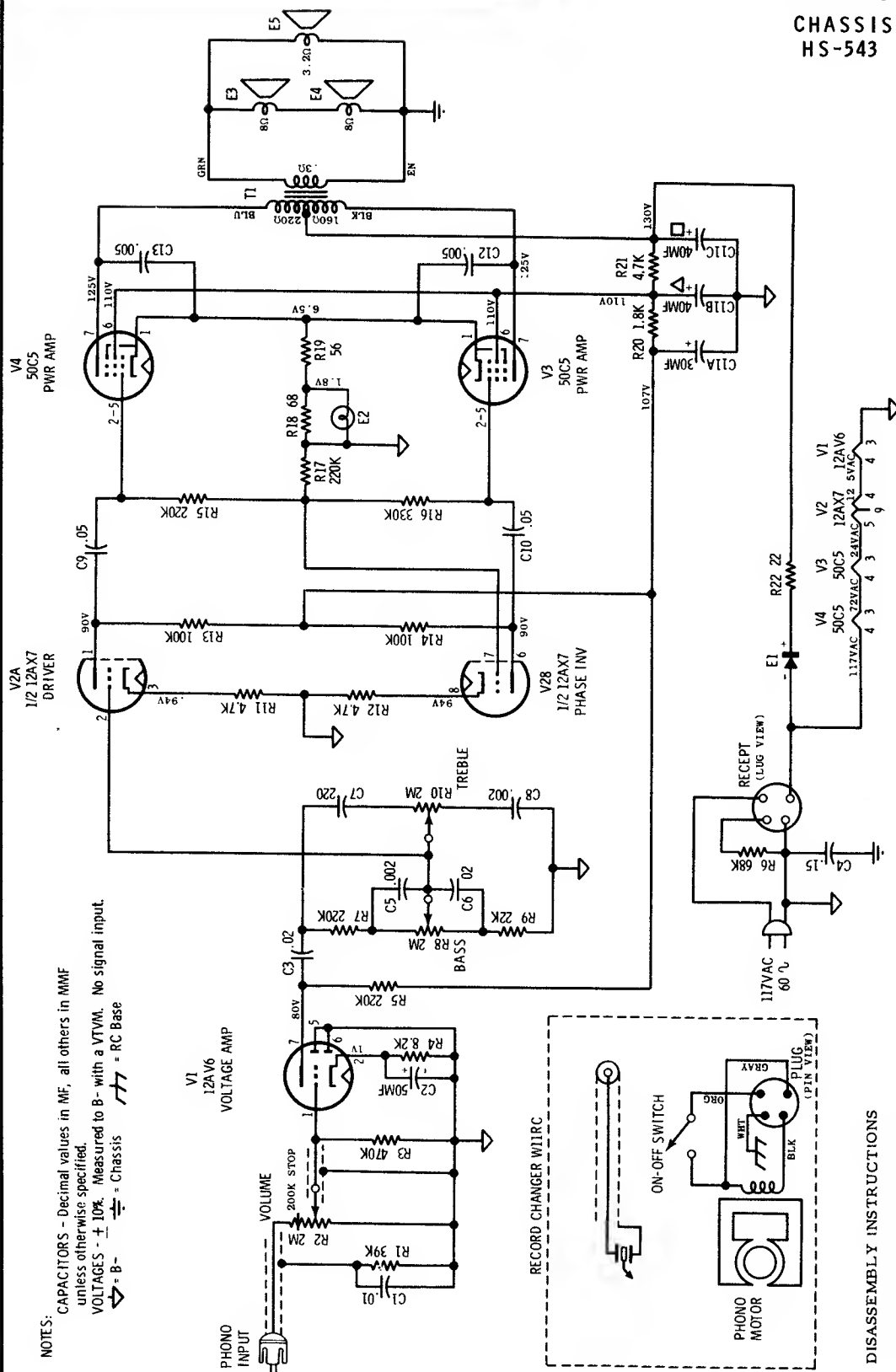

NOTES:  
CAPACITORS - Decimal values in MF, all others in MMF unless otherwise specified.  
VOLTAGES -  $\pm$  10%. Measured to B- with a VTVM. No signal input.  
 $\nabla$  - B- = Chassis  $\nabla$  - RC Base

**To Remove Record Changer from Mounting Board**

1. Turn the record changer mounting screws down flush with the record changer base.
2. From bottom of changer, turn the Timmermann nuts located at the ends of the mounting screws so they are parallel with the screws.
3. Lift record changer off of the mounting board.

**DISASSEMBLY INSTRUCTIONS**

**To Remove Chassis from Cabinet**

1. Remove the four screws which hold the perforated panel in place and remove the panel.
2. Remove the four screws which hold the changer mounting board in place and remove changer board (disconnect all leads from changer).
3. Pull knobs off from front of cabinet.
4. Remove nuts which mount chassis to cabinet and disconnect speaker leads.
5. Remove chassis from cabinet.

# MOTOROLA

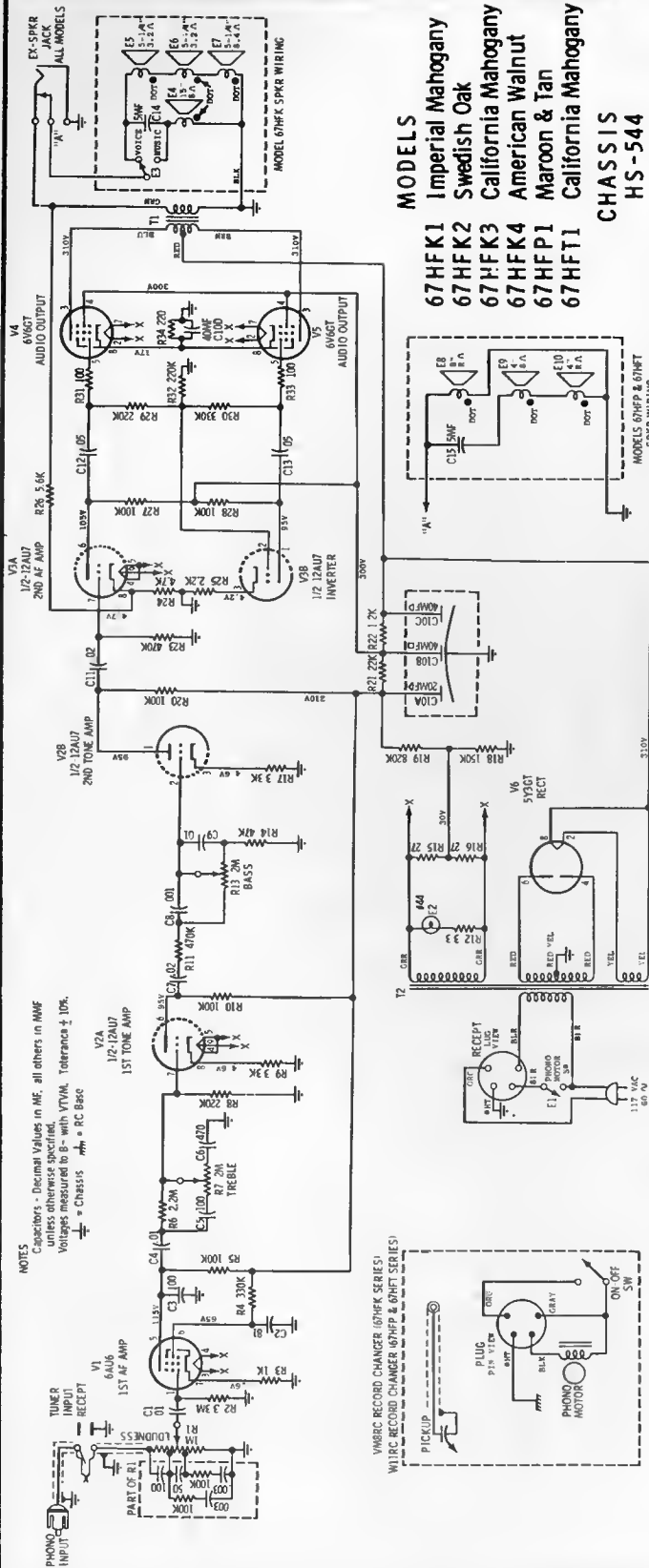

- MODELS**
- 67HFK1 Imperial Mahogany
  - 67HFK2 Swedish Oak
  - 67HFK3 California Mahogany
  - 67HFK4 American Walnut
  - 67HFP1 Maroon & Tan
  - 67HFT1 California Mahogany
- CHASSIS**  
 HS-544

**To Remove Chassis from Cabinet (67HFK series)**

1. Remove VOICE-MUSIC switch from cabinet.
2. Pull off three control knobs.
3. Remove cabinet back cover.
4. Disconnect leads from changer and speakers.
5. Remove two screws that mount chassis to cabinet, slide chassis from cabinet. (67HFP series)
6. Pull off the three control knobs.
7. Remove wingnut from cabinet back cover and remove cover.
8. Remove screws from bottom panel (located at base of cabinet) and remove panel from cabinet.
9. Disconnect leads from changer and speakers.
10. Remove nuts from block of wood adjacent to chassis and lift block of wood out of way.
11. Remove chassis mounting screw and slide chassis out from bottom of cabinet. (67HFT series)
12. Pull off the three control knobs.
13. Remove cabinet back cover.
14. Disconnect leads from changer and speakers.
15. From rear of cabinet, remove two chassis mounting screws from cabinet and slide chassis out of cabinet.

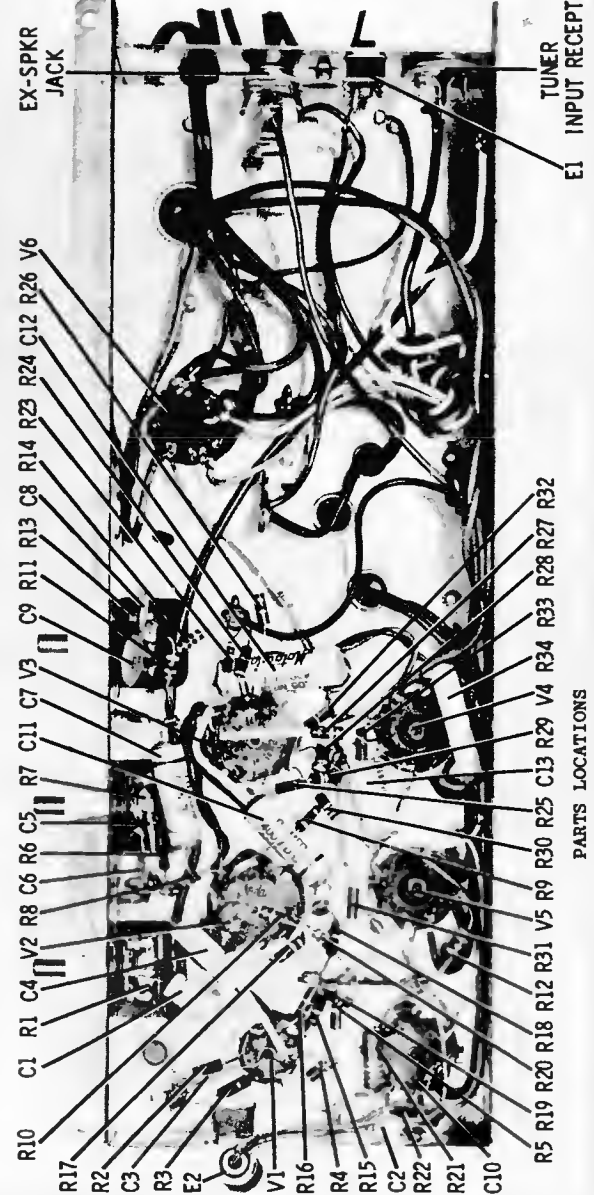

**MOTOROLA INC.**

**MODEL  
BKA6A**

Automotive superheterodyne receiver designed for custom installation in the 1956 Buick.

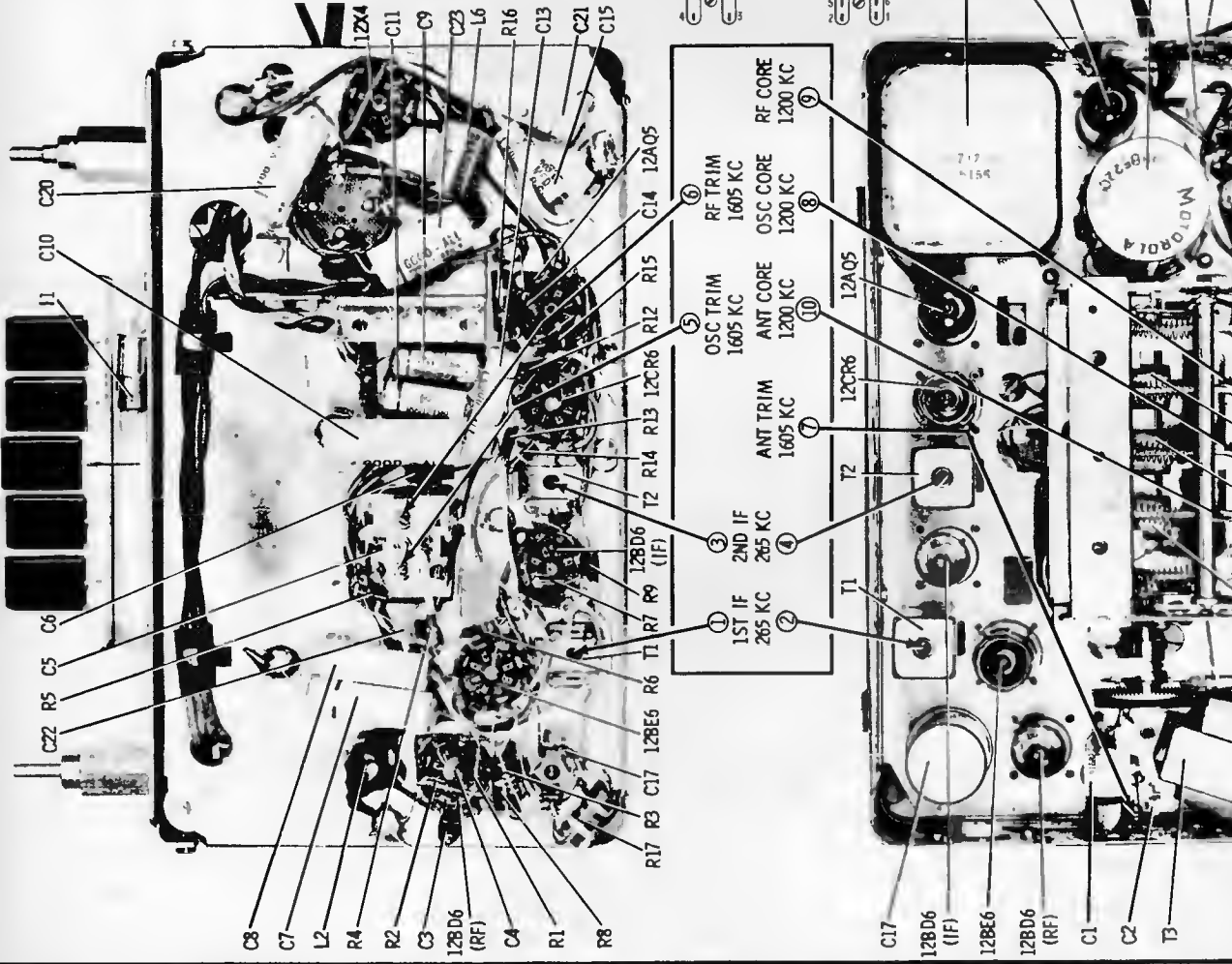
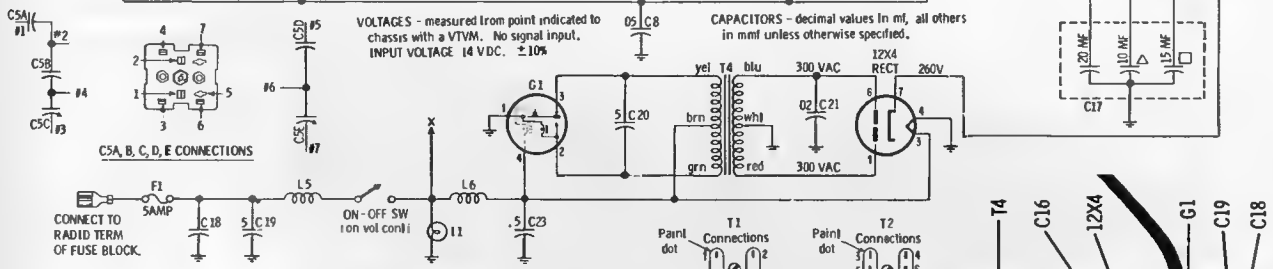
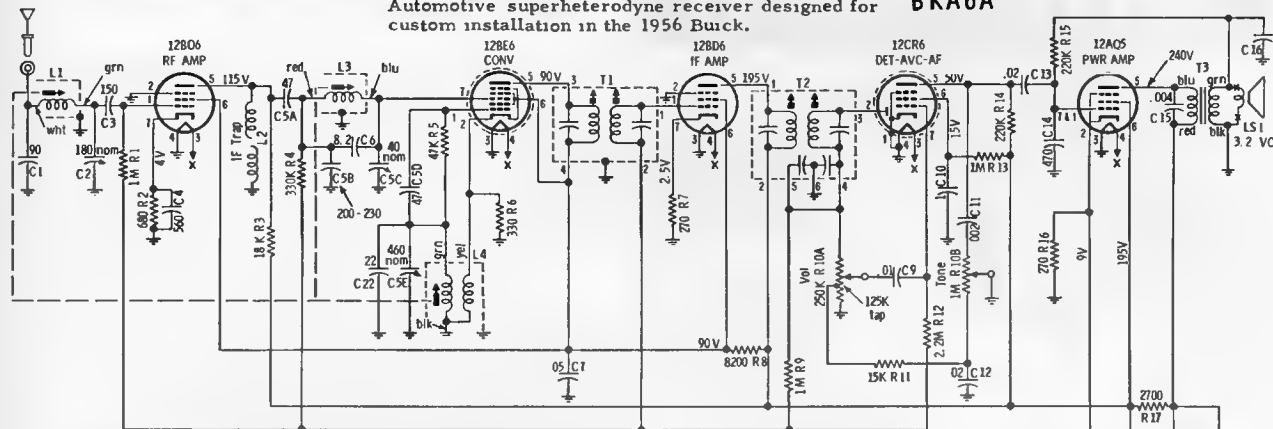

# MOTOROLA

MODEL  
BKA6T

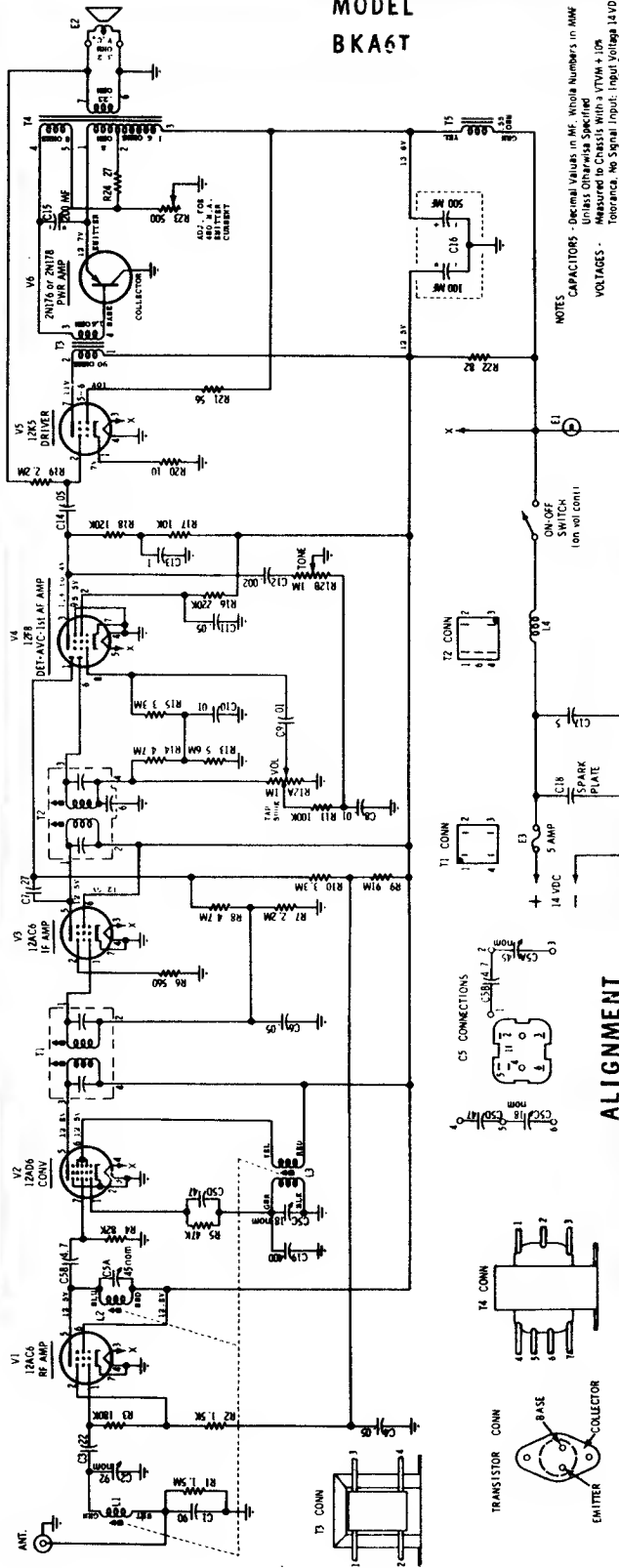

## ALIGNMENT

Connect an output meter across the speaker voice coil. Set tone to high and volume to maximum. Attenuate signal generator output to maintain 1.79 volts on output meter to prevent overloading the receiver.

STEP	GENERATOR CONNECTION	GENERATOR FREQUENCY (400 cycle mod)	TUNER SET TO	ADJUST	REMARKS
1.	IF ALIGNMENT Conv grid (pin 7) .1 mf & thru chassis	455 Kc	Hi end stop	1, 2, 3 & 4	Peak for maximum.
2.	RF ALIGNMENT Ant receipt through dummy (see Fig.)	1610 Kc	Hi end stop	5, 6 & 7	Peak for maximum.
3.	Ant receipt through dummy (see Fig.)	1610 Kc	Hi end stop	5, 6 & 7	Peak for maximum.
4.	"	1200 Kc	Tuner carriage 9/32" from hi end stop	8, 9 & 10	Peak for maximum using alignment tool Motorola Part No. 66A76278.
5.	"	1610 Kc	Hi end stop	5, 6 & 7	Peak for maximum.
6.	Repeat steps 4 & 5 until no further increase; then cement tuning cores in place.				
7.	ANTENNA TRIMMER		Weak station around 1400 Kc	7	With radio installed in car and antenna fully extended, peak antenna trimmer for maximum.

1. RADIO POLARITY - When servicing this radio on the service bench, be sure that the radio housing is connected to the negative side of the power source and that the "A" lead connects to the positive side.

2. TRANSISTOR REPLACEMENT - When replacing a transistor, be sure that the transistor contacts are connected as follows: the lead from the driver transformer T-3 to the base terminal; the lead from the output transformer T-4 to the emitter terminal; the collector is automatically grounded when the transistor is mounted to the heat radiator. The schematic diagram shows the position of the transistor electrodes as viewed from the terminal side. Care should be taken when mounting the transistor to the heat radiator; if not securely mounted, the transistor may be damaged from lack of proper heat dissipation. NOTE: When a transistor is replaced, the emitter current should be checked. (See EMITTER CURRENT ADJUSTMENT).

3. EMITTER CURRENT ADJUSTMENT - To adjust the emitter current, insert a milliammeter in series with the emitter electrode. This can be done by unplugging emitter lead and connecting positive side of milliammeter to lead, and negative side to transistor emitter terminal. Adjust the variable 500 ohm resistor R-23 for 480 ma emitter current. Note: This milliammeter should be a quality instrument with low internal resistance of .1 ohm max.

(For alignment adjustments and parts location see the next page adjacent at right)



# MOTOROLA INC.

Model BKA6T

## Alignment Adjustments and Parts Location

Continued from preceding page at left.

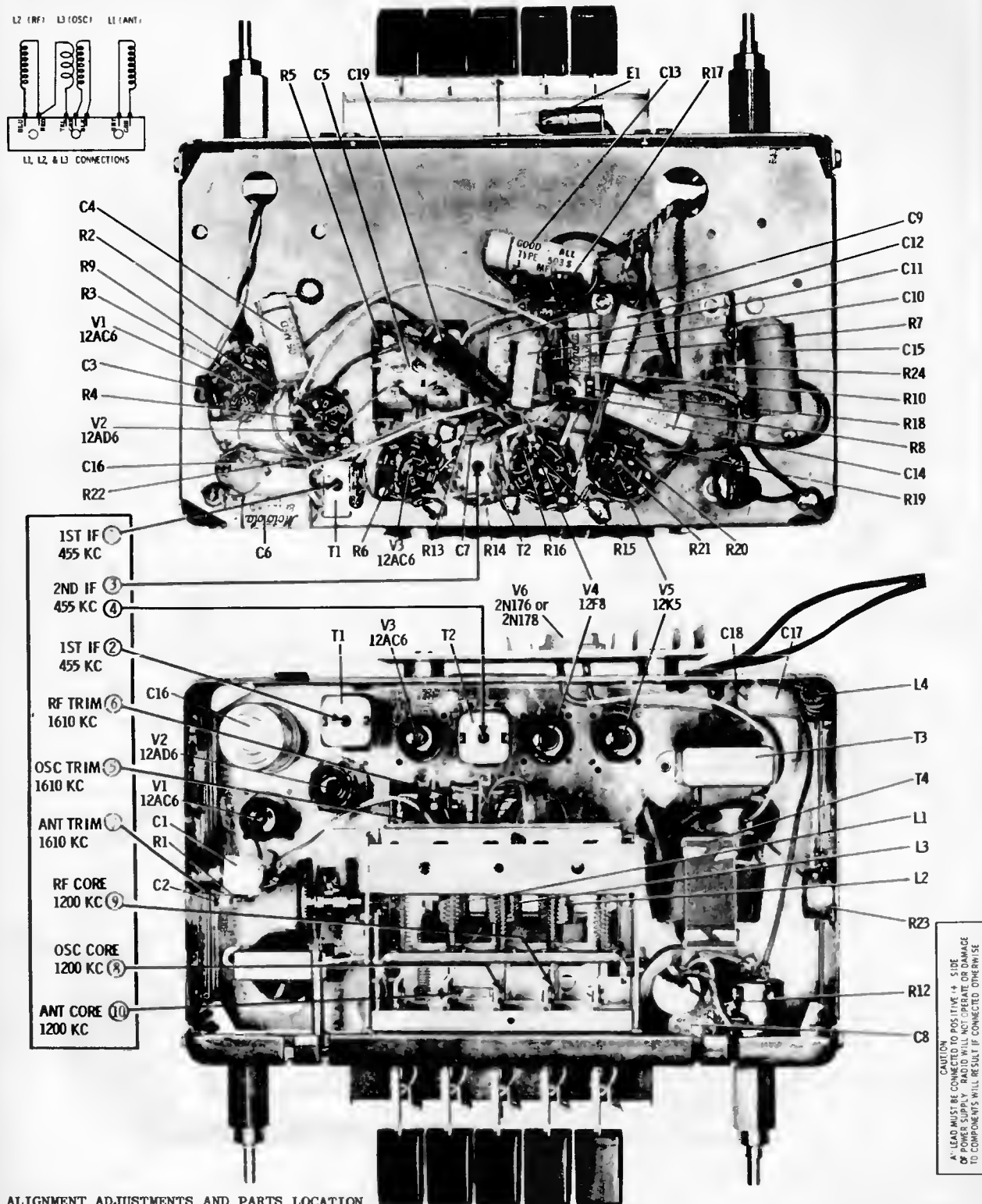
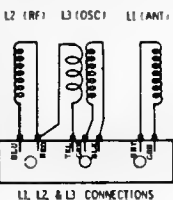
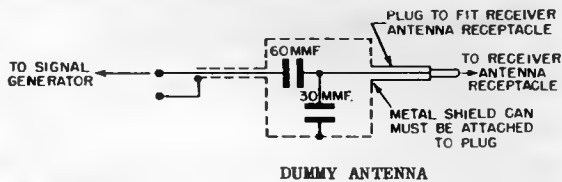

**CAUTION**  
 A LEAD MUST BE CONNECTED TO POSITIVE (+) SIDE OF POWER SUPPLY. RADIO WILL NOT OPERATE OR DAMAGE TO COMPONENTS WILL RESULT IF CONNECTED OTHERWISE.

ALIGNMENT ADJUSTMENTS AND PARTS LOCATION

**MOTOROLA INC.**

AMERICAN MOTORS

MOTOROLA 6MR

8990377

American Motors 8990455, Motorola 7MR, is practically identical to the set described.

**DIAL LIGHTING**

Some receivers have a 270K 10% 1/2W resistor (Motorola Part No. 6R6414) in series with the dial scale. In the event that a dial scale is replaced and the dial scale found to be either too bright or too dim, either add (to reduce brightness) or remove (to increase brightness) the above resistor.

**POINTER CALIBRATION**

Remove the top cover and place the dial scale and pointer on the tuning shaft. With gang fully closed, loosen the tuning pulley setscrew, rotate the tuning pulley to position pointer as shown in Restraining Detail. Tighten the setscrew after calibration.

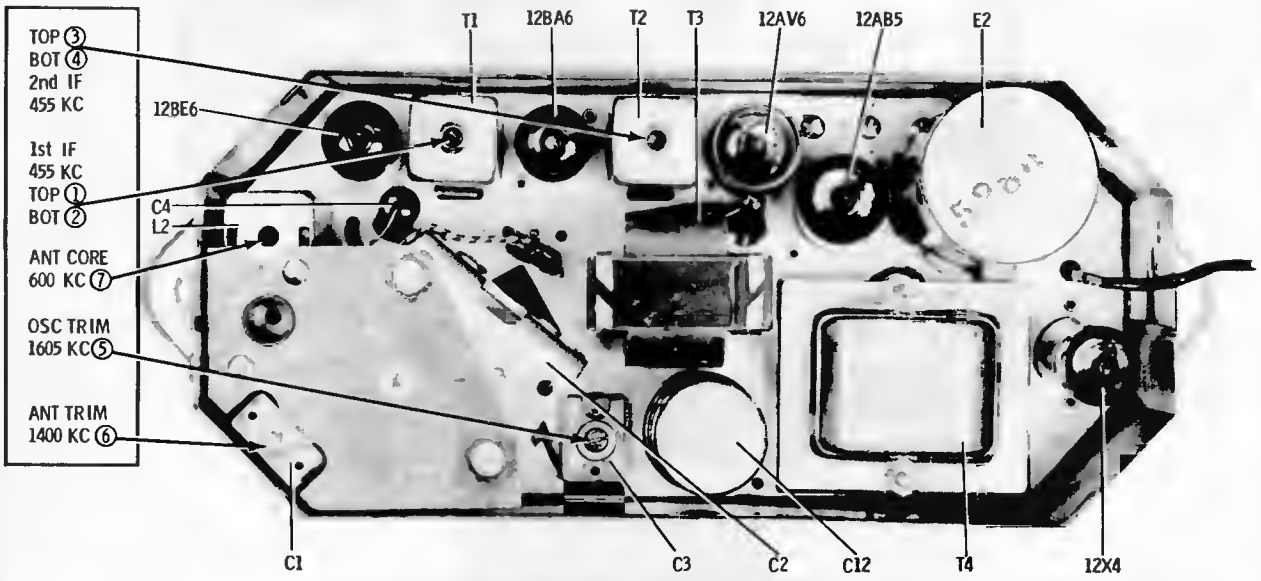
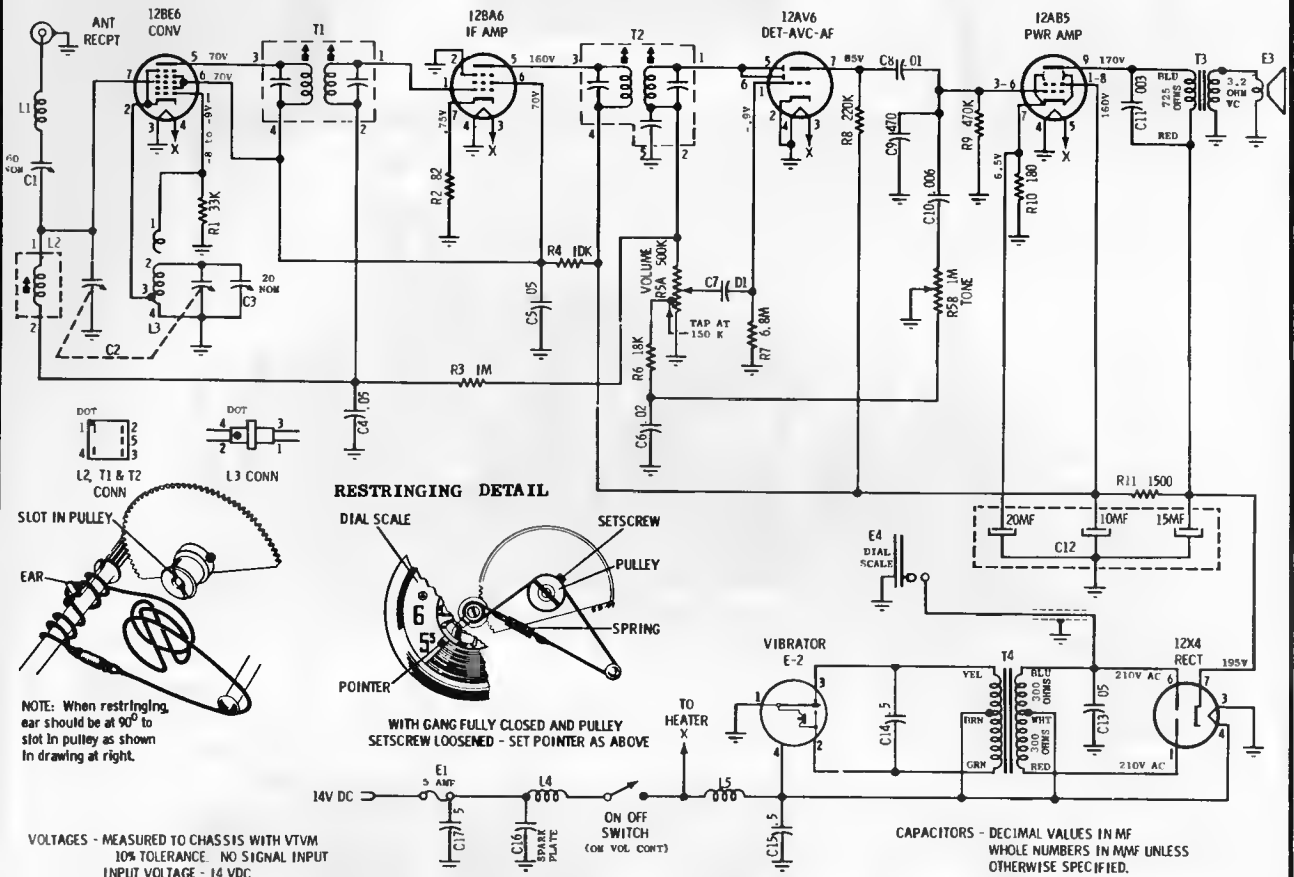

# MOTOROLA INC.

## MODEL MoPar 624

Automotive type superheterodyne plated circuit chassis receiver designed for custom installation in the following 1957 DODGE cars: D66, D67, D70, D71, D72.

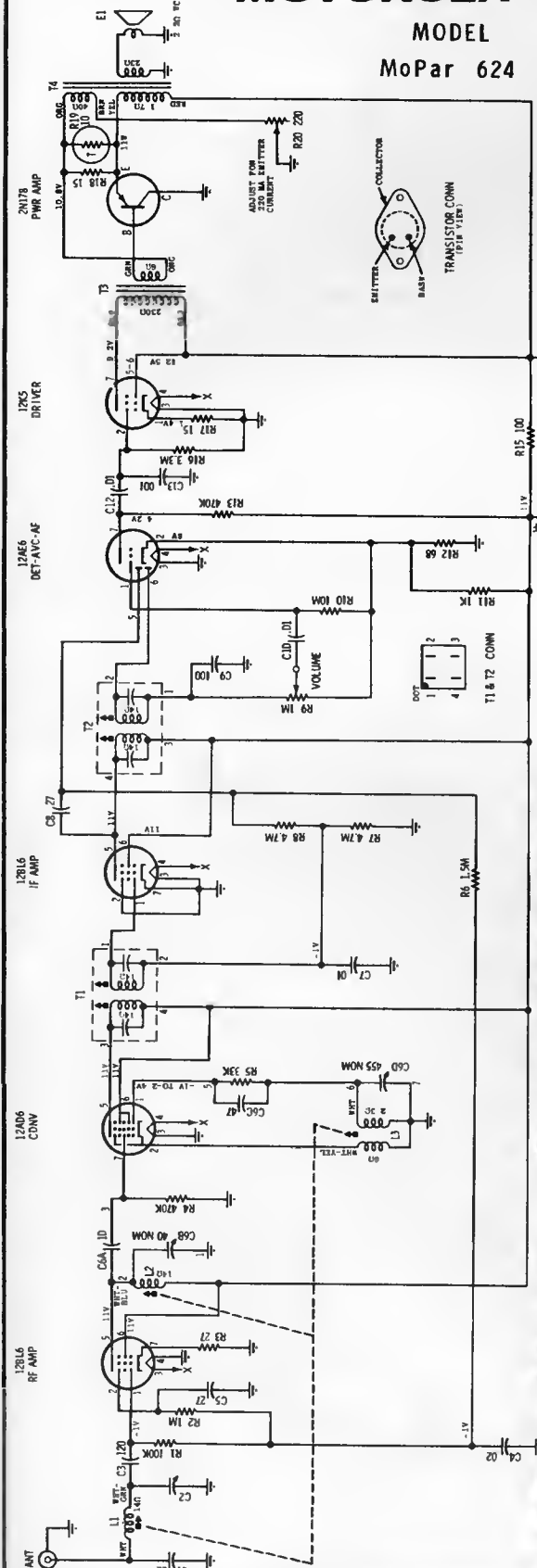

CAPACITORS - Decimal values in  $\mu$ F, all others in  $\mu$ ME unless otherwise specified.  
 VOLTAGES - Measured from point indicated to chassis with a VTVM. Tolerance 10%.  
 No signal input. Input voltage 13.2 VDC.

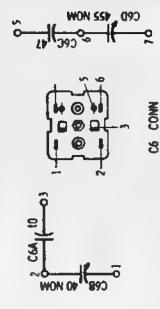

CAUTION  
 "A" LEAD MUST BE CONNECTED TO POSITIVE (+) SIDE OF POWER SUPPLY. RADIO WILL NOT OPERATE OR DAMAGE TO COMPONENTS WILL RESULT IF CONNECTED OTHERWISE

**SERVICING PRECAUTION** - When servicing this receiver, probing with a screwdriver (checking for spark to ground from various points) must be avoided, because the plate power is obtained directly from the storage battery and high currents can flow through the components causing permanent damage. The driver and transistor stages are especially susceptible to damage from this type of check. If the transistor BASE electrode is shorted to ground (either directly or through any other path) the BASE bias will be removed allowing excessive current to flow through the transistor causing permanent damage by melting the indium junctions in the transistor.

**EMITTER CURRENT ADJUSTMENT** - The emitter current is adjusted by variable resistor R-20 for 300 Ma flow through the transistor with 12 volts at the receiver's "A" lead. The current is adjusted by measuring the voltage drop across T-4 primary winding. Connect the negative lead of a low range VTVM to the yellow lead of T-4 (top of primary winding) and the positive VTVM lead to the red lead (bottom of primary) of T-4; adjust R-20 for a .51 volt reading.

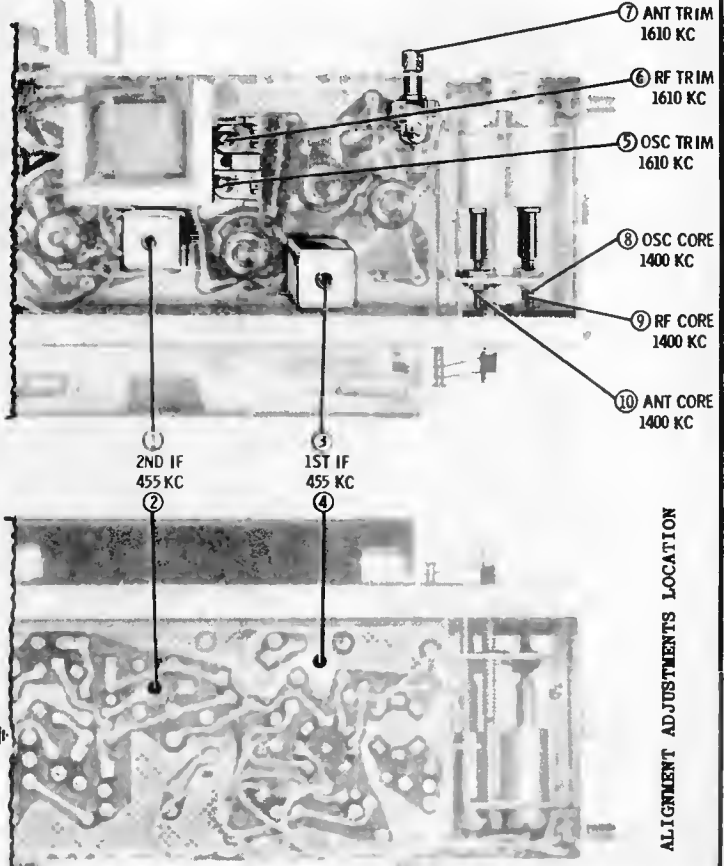

ALIGNMENT ADJUSTMENTS LOCATION

# MOTOROLA

MOTOROLA 75MF

FORD FEG-18806-H

(For alignment see the next page adjacent at right)

## SERVICE NOTES

**RADIO POLARITY** - WHEN SERVICING THIS RECEIVER ON THE SERVICE BENCH, BE SURE THAT THE RECEIVER "A" LEAD IS CONNECTED TO THE POSITIVE SIDE OF THE POWER SOURCE AND THAT THE RECEIVER HOUSING IS CONNECTED TO THE NEGATIVE SIDE. IF CONNECTED OTHERWISE, THE RECEIVER WILL NOT OPERATE AND DAMAGE TO COMPONENTS MAY RESULT.

**TRANSISTOR REPLACEMENT** - When replacing a transistor, be sure that the transistor mounting screws are securely tightened. If not securely tightened, the transistor may be damaged from lack of proper heat dissipation. NOTE: When a transistor is replaced, the emitter current should be checked (see EMITTER CURRENT ADJUSTMENTS).

**EMITTER CURRENT ADJUSTMENT** - The emitter current is adjusted by variable resistor R-23 for 390 Ma flow through the transistor with 12 volts at the receiver's "A" lead. The current is adjusted by measuring the voltage drop across the top section of T-4 primary winding. Connect the negative lead of a low range VTVM to the yellow lead of T-4 (top of primary winding) and the positive VTVM lead to the white lead (tap on primary) of T-4; adjust R-23 for a .82 volt reading (see ALIGNMENT LOCATIONS photo).

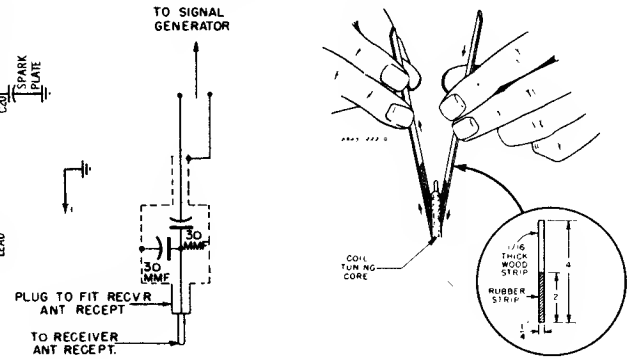
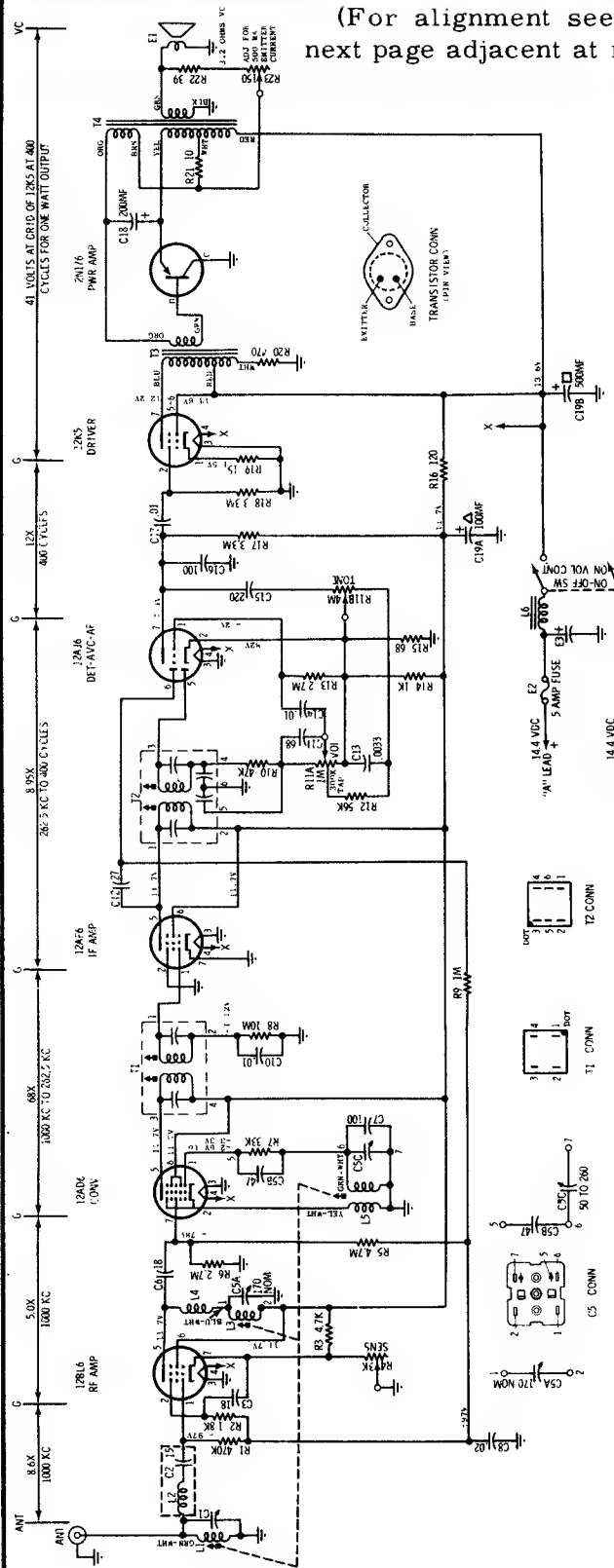

DUMMY ANTENNA DATA

CORE ALIGNMENT TOOL DETAIL

6. **TRANSISTOR CHECK** - The transistors used in this receiver can be expected to give unusually long trouble-free life. However, the following transistor checks are provided to facilitate servicing:

Substituting a known good transistor for a suspected one is the simplest and most positive way of checking transistors.

The transistor may be checked for shorts and opens by using an ohmmeter. This check primarily measures the ability of a transistor to conduct current in one direction and to resist current flow in the opposite direction. The resistance in the conduction direction is very low in relation to the resistance in the non-conduction direction. This check is made by connecting the ohmmeter leads as shown in illustration.

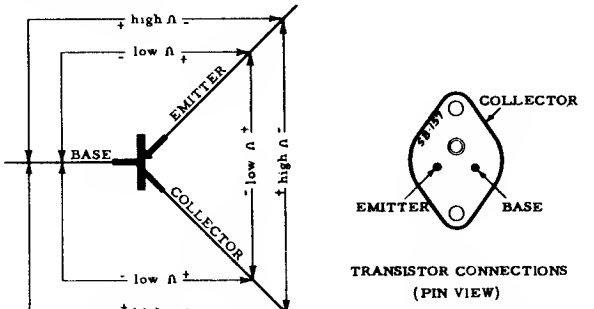

# VOLUME R-17, MOST-OFTEN-NEEDED 1957 RADIO SERVICING INFORMATION

## MOTOROLA 75MF, FORD FEG-18806-H, Alignment Information (Continued)

Connect an output meter across the speaker voice coil. Set tone control to high and volume control to maximum. Attenuate signal generator output to maintain 1.79 volts (1 watt) on output meter to prevent overloading. Input voltage should be 14.4 volts.

STEP	GENERATOR CONNECTION	GENERATOR FREQUENCY (400 cycle mod)	TUNER SET TO	ADJUST	REMARKS
<b>IF ALIGNMENT</b>					
1.	12AD6 grid (pin 7) thru .1 mf & chassis	262.5 Kc	Hi end stop	1, 2, 3 & 4	Adjust for maximum.
<b>RF ALIGNMENT</b>					
2.	Antenna recept thru dummy	1610 Kc	Hi end stop	5, 6 & 7	Adjust for maximum.
NOTE: Do not perform steps 3, 4, 5 & 6 unless tuner has been tampered with or components have been replaced. Before proceeding with step 3, back tuning cores 1-3/8" out of tuning coils to eliminate their effect on trimmer adjustment.					
3.	Antenna recept thru dummy (see Figure)	1610 Kc	Hi end stop	5, 6 & 7	Adjust for maximum.
4.	"	1020 Kc	25/32" from hi end stop	8, 9 & 10	Adjust for maximum.
5.	"	1610 Kc	Hi end stop	5, 6 & 7	Adjust for maximum.
6. Repeat steps 4 & 5 until no further increase, then cement cores in place; last adjustment should be step 5.					
<b>SENSITIVITY CONTROL</b>					
7.	Antenna recept thru dummy	600 Kc at 5 microvolts	Tune for max	Sensitivity control	Adjust for 1.79 volts output.
<b>ANTENNA TRIMMER</b>					
8.			Weak station around 1400 Kc	7	Adjust for maximum with radio installed in car and antenna fully extended.

### TO CALIBRATE POINTER

Tune radio to 1000 Kc signal and rotate pointer adjusting cam until center of pointer coincides with the center of the 1000 Kc mark on dial scale.

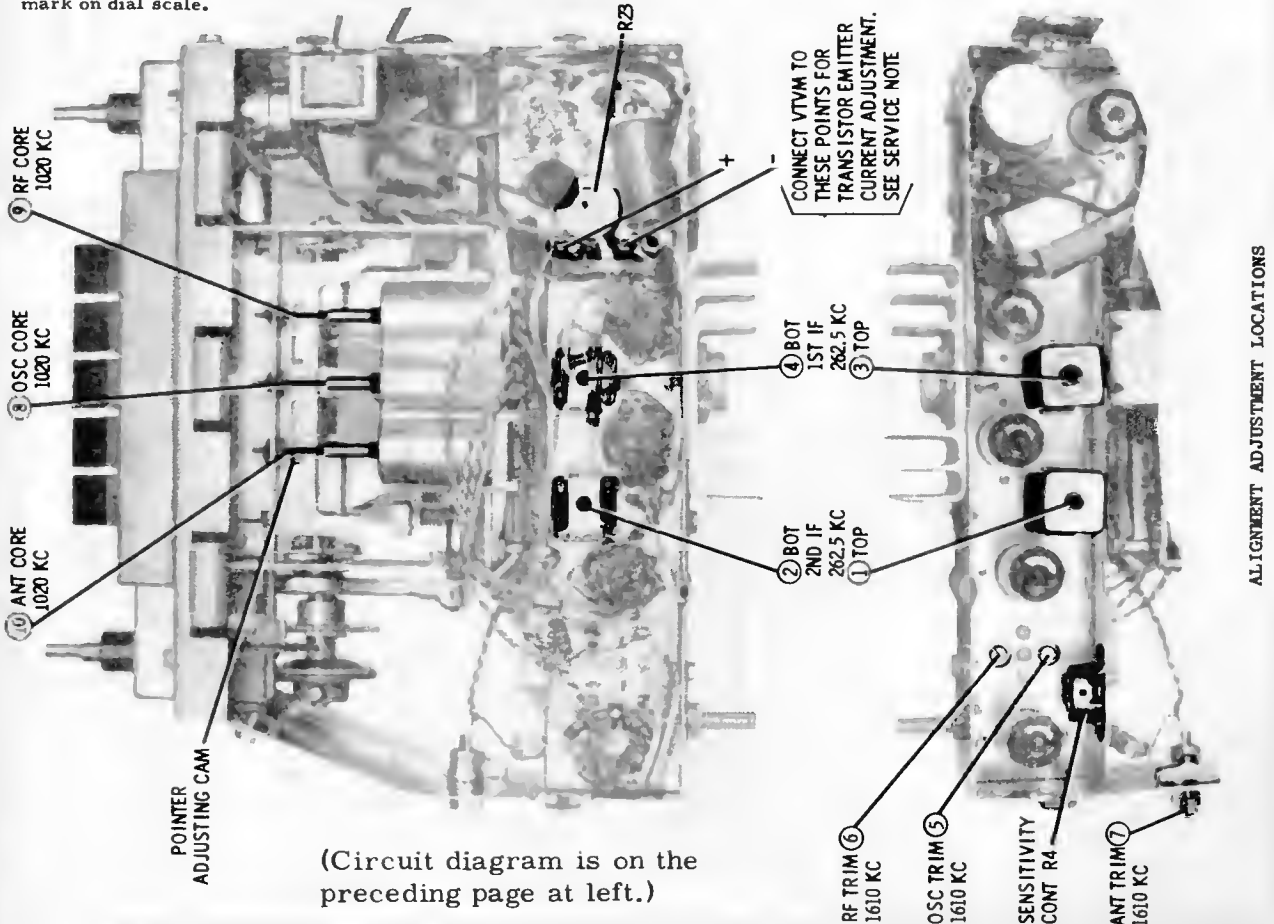

**MOTOROLA INC.**

**AUTO RADIO  
MOTOROLA 78MF**

**FORD FEG-18806-G**

(Alignment information is on the next page adjacent at right)

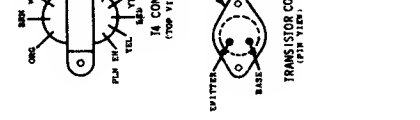
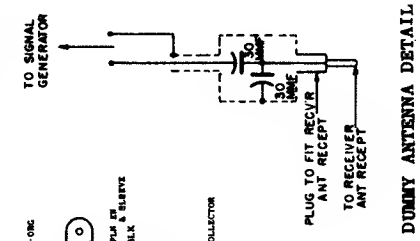
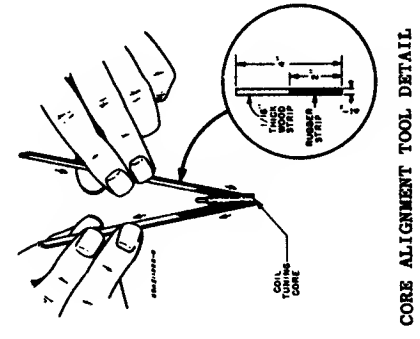
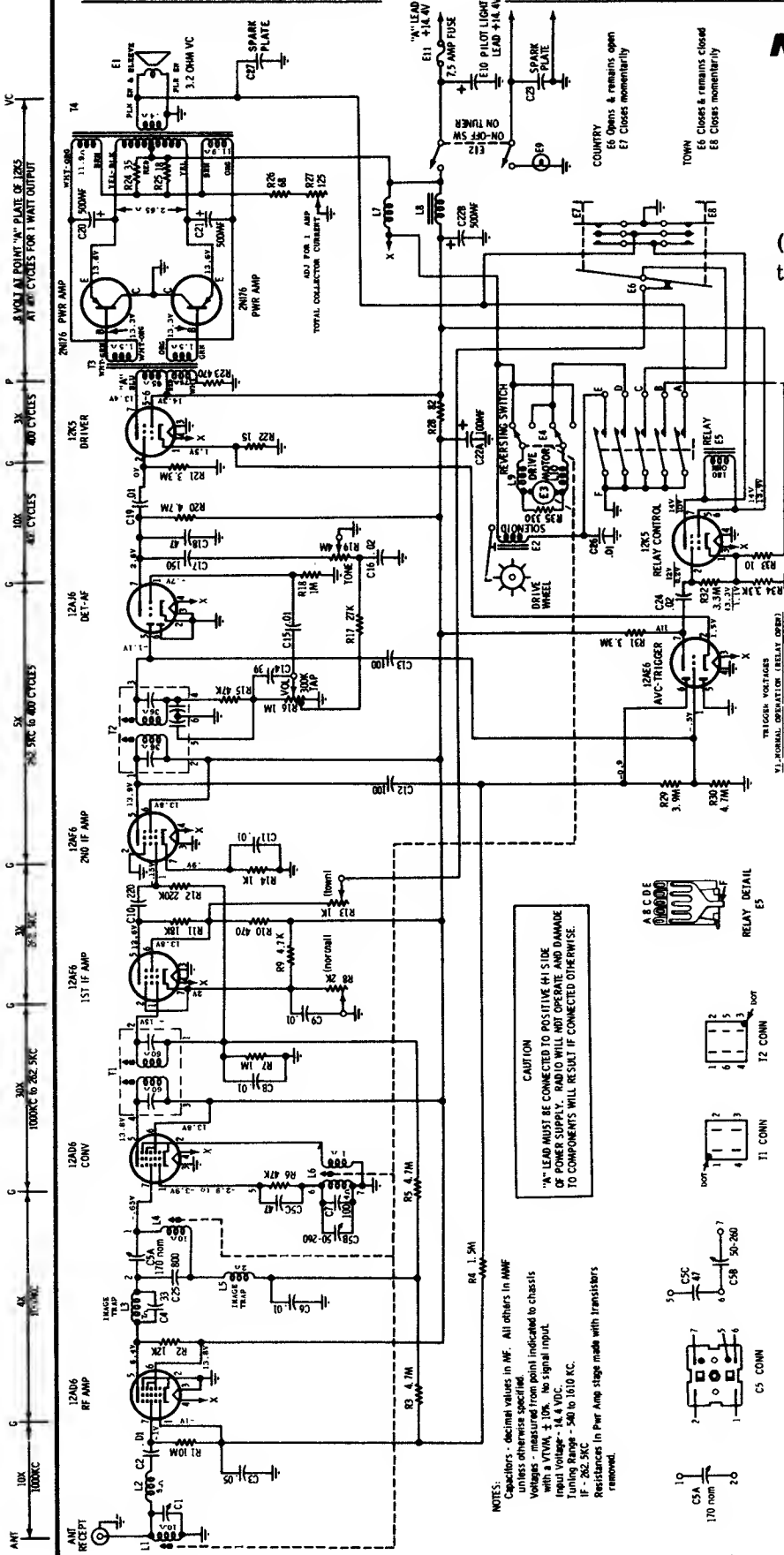

**CAUTION**  
"W" LEAD MUST BE CONNECTED TO POSITIVE (+) SIDE OF POWER SUPPLY. RADIO WILL NOT OPERATE AND DAMAGE TO COMPONENTS WILL RESULT IF CONNECTED OTHERWISE.

**NOTES:**  
Capacitors - decimal values in MF. All others in MMF unless otherwise specified.  
Voltages - measured from point indicated to chassis with a VTVM,  $\pm 10\%$ , no signal input.  
Input voltage - 14.4 VOLTS.  
Tuning range - 540 to 1610 KC.  
Resistors in Par Amp stage made with transistors removed.

**COLLECTOR CURRENT ADJUSTMENT** - The collector current is adjusted by variable resistor R-27, for a 870 Ma flow through the transistors, with 12 volts at the receiver's "A" lead. Separate the transistor mounting heat sink from the housing, connect the negative lead of a low internal resistance milliammeter to the radio housing and the positive lead to the heat sink. Adjust variable resistor R-27, for 870 milliamperes.

**NOTE:** Internal resistance of milliammeter should not exceed .5 ohm.

**T-2 COUPLING** - The coupling of IF transformer T-2 has been increased by soldering a 1-1/2" length of insulated wire from pin #3 of T-2, and winding one turn of this wire around the plate lead of capacitor C-12. When replacing either T-2 or C-12, this wire should also be replaced, if omitted, the stopping accuracy of the receiver will be affected.

(Alignment data on the next page)

# VOLUME R-17, MOST-OFTEN-NEEDED 1957 RADIO SERVICING INFORMATION

Connect a VTVM from the AVC line to ground (pin #1 of 12AD6 RF amp & chassis). Set volume to minimum and tone to treble. Attenuate signal generator to maintain VTVM reading between 1.5 and 2 volts.

STEP	GENERATOR CONNECTION	GENERATOR FREQUENCY (400 cycle mod)	TUNER SET TO	ADJUST	REMARKS
<b>IF ALIGNMENT</b>					
1.	12AD6 conv. grid (pin 7) thru .1 mf & chassis	262.5 Kc	Hi end stop	2, 3 & 4	Adjust for maximum.
2.	"	"	"	1	Adjust for dip.
<b>RF ALIGNMENT</b>					
3.	Antenna recept thru dummy	1610 Kc	Hi end stop	5, 6 & 7	Adjust for maximum.
<b>NOTE: Do not perform steps 4, 5, 6 &amp; 7 unless the tuner has been tampered with or components have been replaced. Before proceeding with step 4, back tuning cores 1-3/8" out of tuning coils to eliminate their effect on trimmer adjustment.</b>					
4.	Antenna recept thru dummy	1610 Kc	Hi end stop	5, 6 & 7	Adjust for maximum.
5.	"	1020 Kc	49/64" from hi end stop	8, 9 & 10	Adjust for maximum.
6.	"	1610 Kc	Hi end stop	5, 6 & 7	Adjust for maximum.
7. Repeat steps 5 & 6 until no further increase, then cement cores in place. Step No. 6 should be last adjustment.					
<b>SENSITIVITY CONTROLS</b>					
8.	Antenna recept thru dummy (see Figure)	1000 Kc at 5 microvolts	Tune for max	R8	Adjust for 1.79 volts output. (Connect output meter across voice coil and set volume control to maximum).
9.	"	1000 Kc at 100 microvolts	Tune for max	R13	Short case of R13 to chassis. Adjust for 1.79 volts output. (Connect output meter across voice coil and set volume control to maximum).
<b>ANTENNA TRIMMER ADJUSTMENT</b>					
10.			Weak station around 1400 Kc	7	Adjust for maximum with radio installed in car and antenna fully extended.

MOTOROLA 78MF, FORD FEG-18806-G, ALIGNMENT INFORMATION (Continued)

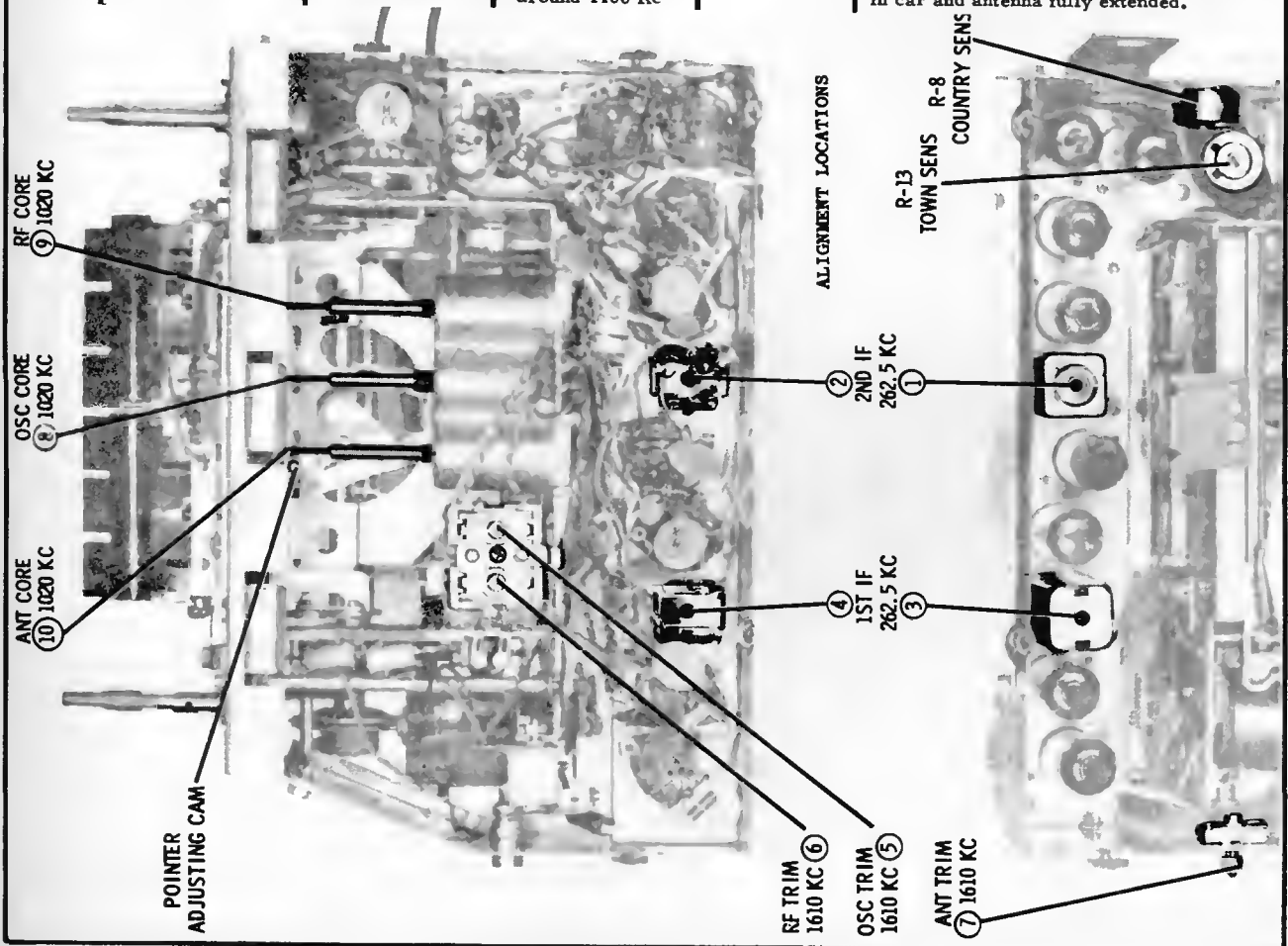

**MOTOROLA INC.**

MoPar Models 845, 846, and 849

Circuit diagram of Model 849 below; circuit for Models 845 and 846 is on the next page, adjacent at right. Alignment detail illustrations continued on the page following the circuits.

Model 845 Dodge D66, D67, D70, D71, D72  
 Model 846 DeSoto S25, S26, S27  
 Model 849 Plymouth P30, P31

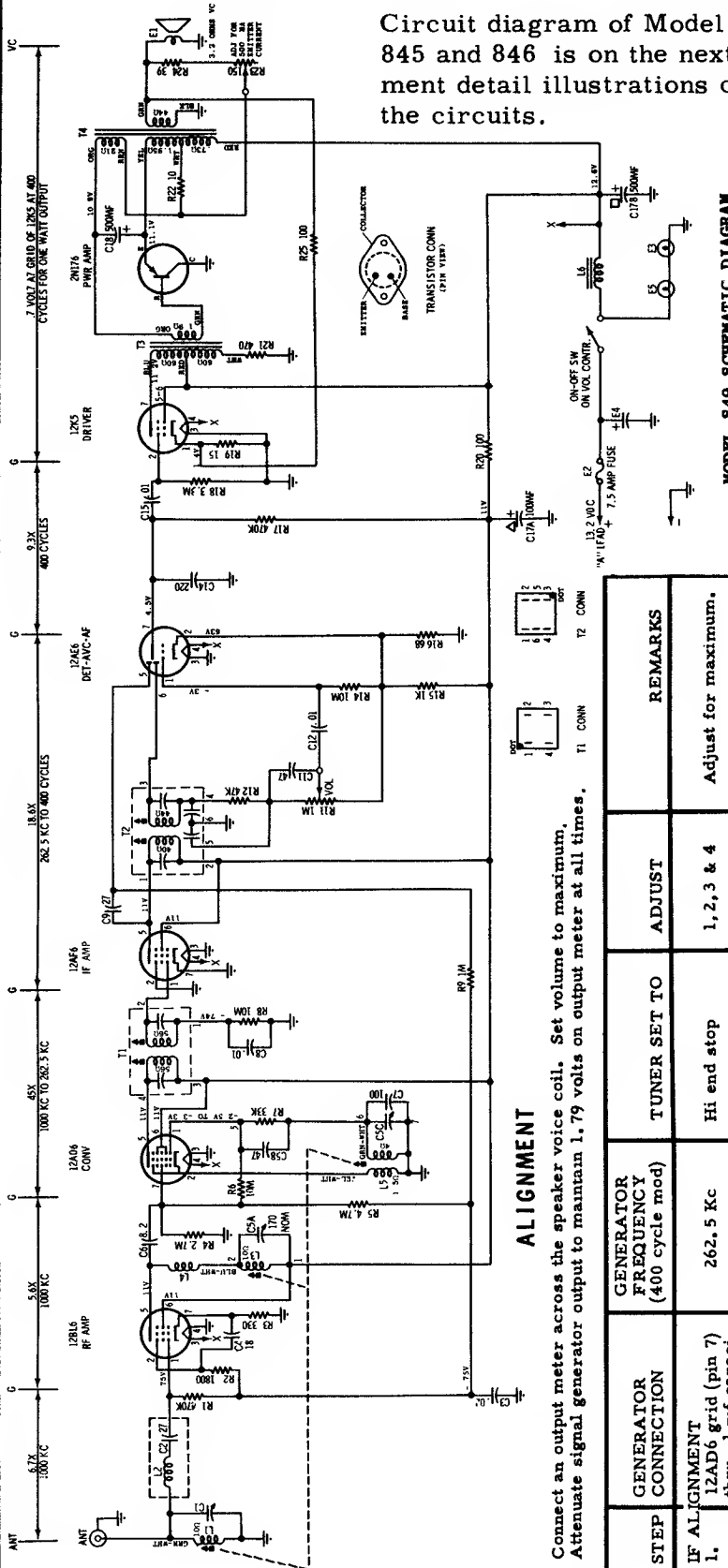

**MODEL 849 SCHEMATIC DIAGRAM**

NOTES  
 Capacitors - Decimat values in  $\mu$ F. All others in pF.  
 Voltages - Measured from point indicated to chassis with a VTVM. Tolerance  $\pm 10\%$ .  
 No signal input. Input voltage 13.2 VDC.

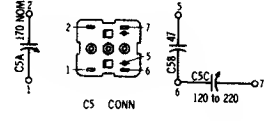

**ALIGNMENT**

Connect an output meter across the speaker voice coil. Set volume to maximum. Attenuate signal generator output to maintain 1.79 volts on output meter at all times.

STEP	GENERATOR CONNECTION	GENERATOR FREQUENCY (400 cycle mod)	TUNER SET TO	ADJUST	REMARKS
1.	12AD6 grid (pin 7) thru .1 mf capacitor & chassis	262.5 Kc	Hi end stop	1, 2, 3 & 4	Adjust for maximum.
2.	Ant recept thru dummy antenna (see Figure)	1610 Kc	Hi end stop	5, 6 & 7	Adjust for maximum.
3.	Ant recept thru dummy antenna (see Figure)	1610 Kc	Hi end stop	5, 6 & 7	Adjust for maximum.
4.	"	1020 Kc	49/64" from hi end stop	8, 9 & 10	Adjust for maximum. Use alignment tool Part No. 66A76278.
5.	"	1610 Kc	Hi end stop	5, 6 & 7	Adjust for maximum.
6.	Repeat steps 4 and 5 until no further increase;				Step 5 should be the last step.
7.	ANTENNA TRIMMER		Weak station around 1400 Kc	7	With radio installed in car and antenna fully extended, peak antenna trimmer for maximum.



**MOTOROLA**

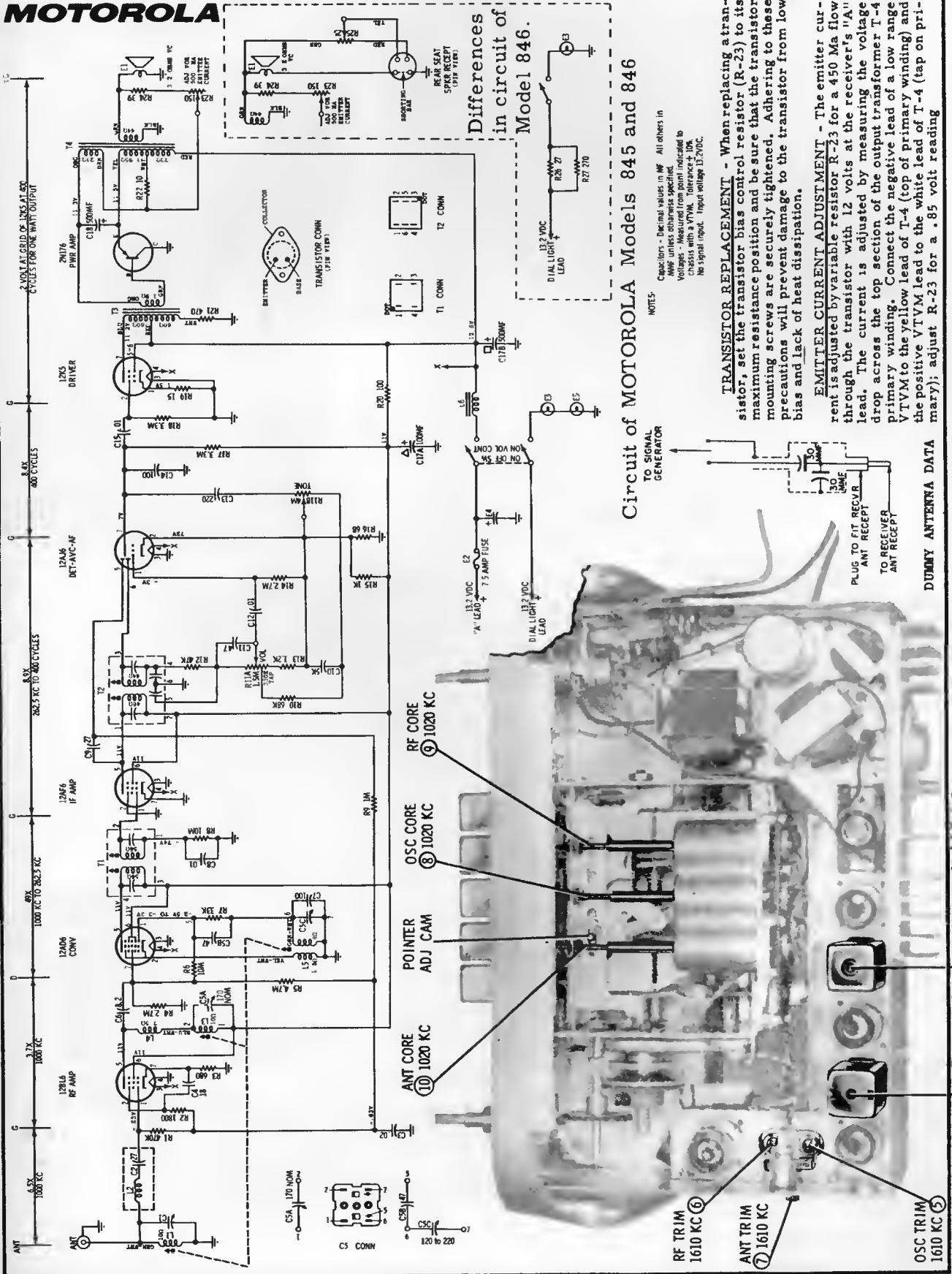

**Circuit of MOTOROLA Models 845 and 846**

**Differences in circuit of Model 846.**

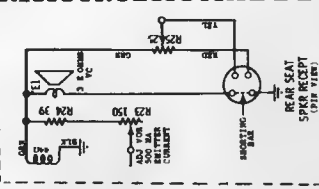

**NOTES:**  
 Capacitors - Decimal values in MF. All others in MME unless otherwise specified.  
 Voltages - Measured from point indicated to chassis with a VTVM. Tolerance ± 10%.  
 No signal input. Input voltage 115/200V.

**TRANSISTOR REPLACEMENT** - When replacing a transistor, set the transistor bias control resistor (R-23) to its maximum resistance position and be sure that the transistor mounting screws are securely tightened. Adhering to these precautions will prevent damage to the transistor from low bias and lack of heat dissipation.

**EMITTER CURRENT ADJUSTMENT** - The emitter current is adjusted by variable resistor R-23 for a 450 Ma flow through the transistor with 12 volts at the receiver's "A" lead. The current is adjusted by measuring the voltage drop across the top section of the output transformer T-4 primary winding. Connect the negative lead of a low range VTVM to the yellow lead of T-4 (top of primary winding) and the positive VTVM lead to the white lead of T-4 (tap on primary); adjust R-23 for a .85 volt reading.

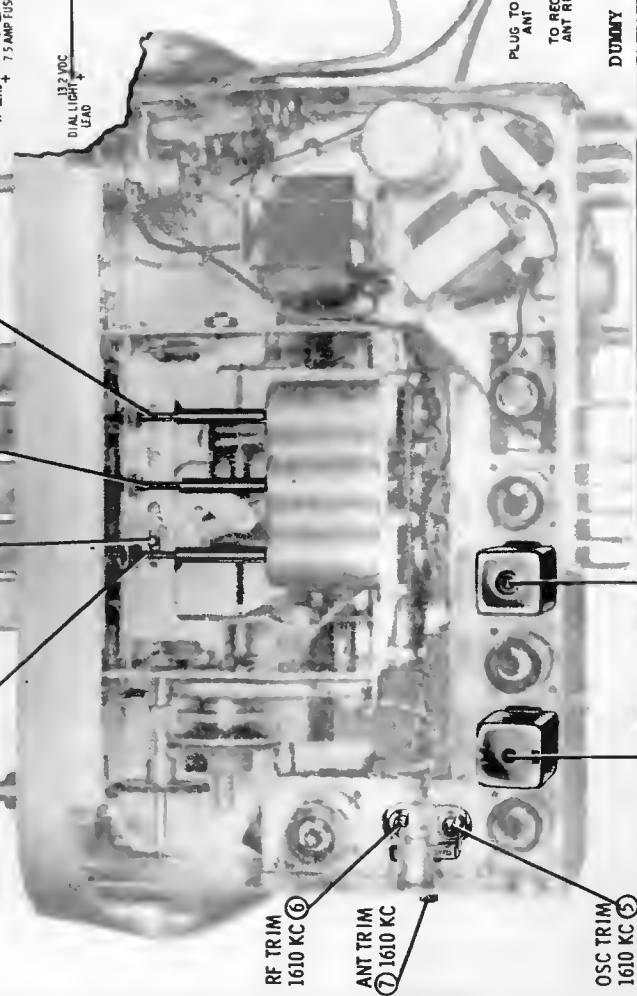

**DUMMY ANTENNA DATA**

- ① 1ST IF 262.5 KC
- ② 2ND IF 262.5 KC
- ③ AND ④ ARE BELOW
- ⑤ MODEL #46 ALIGNMENT DETAIL

MOTOROLA Models 845 and 849 Alignment Detail (Continued)

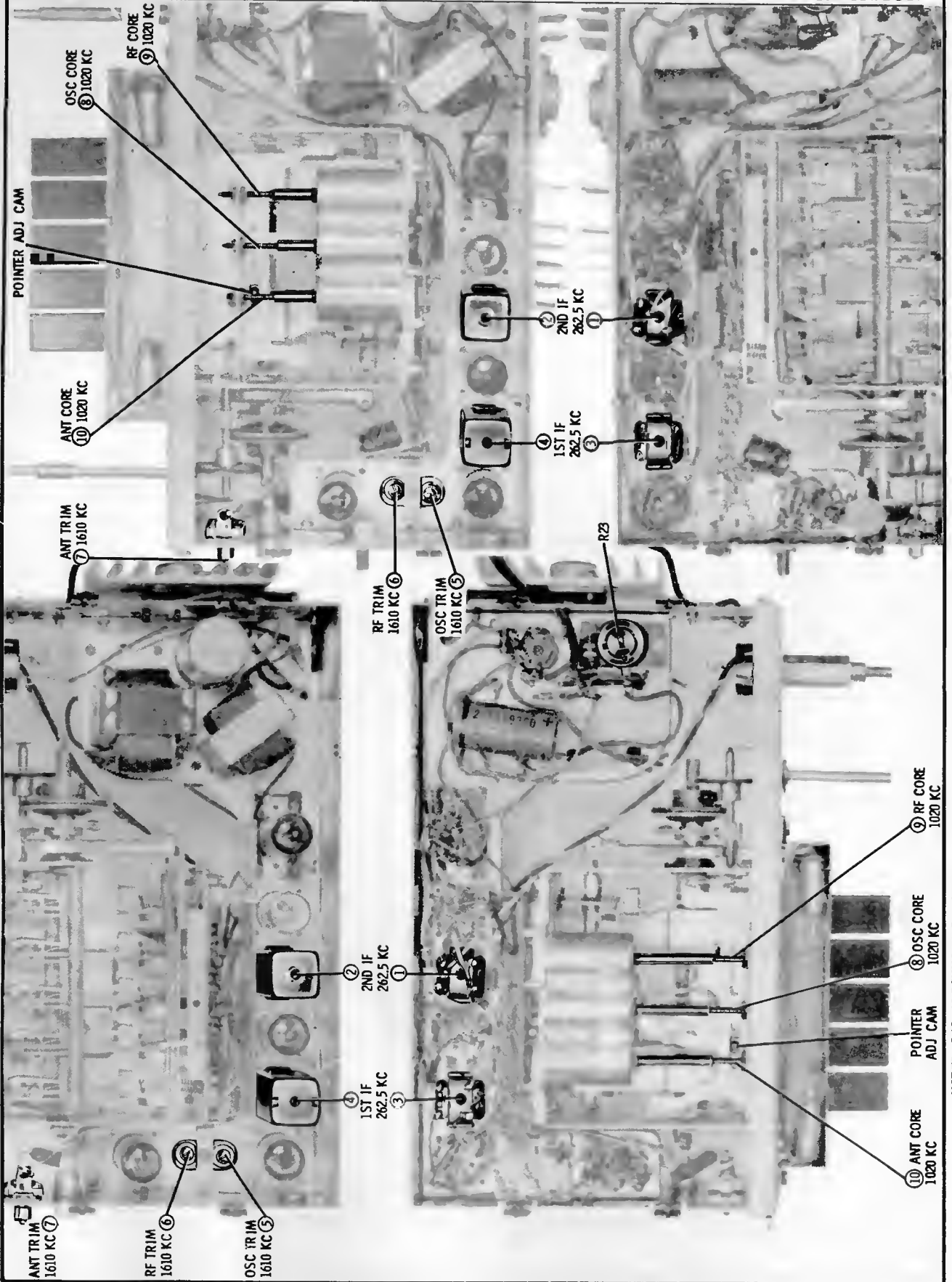

MODEL 845 ALIGNMENT DETAIL

MODEL 849 ALIGNMENT DETAIL

**MOTOROLA**

MoPar 918, used in 1957 Dodge D66, D67, D70, D71, D72.  
Mopar 919, used in 1957 DeSoto S25, S26, S27, is very similar. Alignment information is on the next page, over.

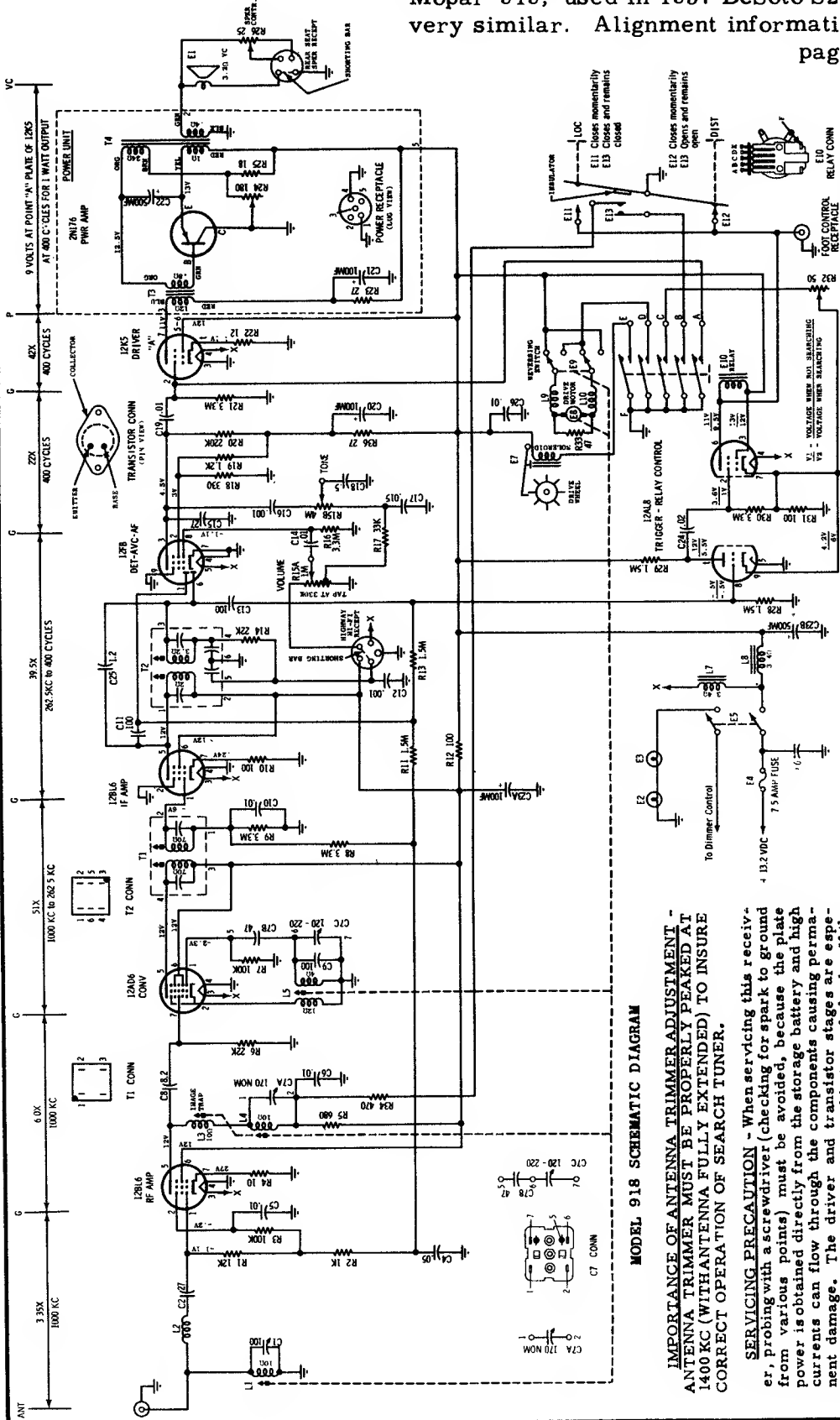

MODEL 918 SCHEMATIC DIAGRAM

**IMPORTANCE OF ANTENNA TRIMMER ADJUSTMENT - ANTENNA TRIMMER MUST BE PROPERLY PEAKED AT 1400 KC (WITH ANTENNA FULLY EXTENDED) TO INSURE CORRECT OPERATION OF SEARCH TUNER.**

**SERVICING PRECAUTION -** When servicing this receiver, probing with a screwdriver (checking for spark to ground from various points) must be avoided, because the plate power is obtained directly from the storage battery and high currents can flow through the components causing permanent damage. The driver and transistor stages are especially susceptible to damage from this type of check. If the transistor BASE electrode is shorted to ground (either directly or through any other path) the BASE bias will be removed, allowing excessive current to flow through the transistor, causing permanent damage by melting the indium junctions in the transistor.

**TRANSISTOR REPLACEMENT -** When replacing a transistor, set the transistor bias control resistor (R-24) to its maximum resistance position and be sure that the transistor mounting screws are securely tightened. Adhering to these precautions will prevent damage to the transistor from low bias and lack of heat dissipation. NOTE: After replacing a transistor, adjust the EMITTER current as explained under EMITTER CURRENT ADJUSTMENT.

**EMITTER CURRENT ADJUSTMENT -** The emitter current is adjusted by variable resistor R-24 for a 900 Ma flow through the transistor with 12 volts at the receiver's 'A' lead. The current is adjusted by measuring the voltage drop across the primary winding of a low range VTVM to the yellow lead of T-4 (top of primary winding) and the positive lead to the red lead of T-4 (bottom of primary); adjust R-24 for a .86 volt reading on VTVM

**TUBE CHECK -** Substituting a known good tube for a suspected one is the best and only check recommended at this time.

**NOTES:**  
CAPACITORS - decimal values in MF, all others in MMF unless otherwise specified.  
VOLTAGES - measured from point indicated to chassis with a VTVM, 1.0K, No signal input.  
INPUT VOLTAGE - 117 VAC  
Refer to Pwr Amp plug, make with transistor removed.

**CAUTION**  
"A" LEAD MUST BE CONNECTED TO POSITIVE (+) SIDE OF POWER SUPPLY. RADIO WILL NOT OPERATE AND DAMAGE TO COMPONENTS WILL RESULT IF CONNECTED OTHERWISE.

# VOLUME R-17, MOST-OFTEN-NEEDED 1957 RADIO SERVICING INFORMATION

## MOTOROLA MoPar 918 and MoPar 919 ALIGNMENT Continued

Connect a VTVM across the AVC line and ground (see ALIGNMENT LOCATIONS detail). Set volume control to its mid-position. Attenuate signal generator output to maintain 1.5 to 2 volts on VTVM at all times to prevent overloading the receiver.

STEP	GENERATOR CONNECTION	GENERATOR FREQUENCY (400 cycle mod)	TUNER SET TO	ADJUST	REMARKS
<b>IF ALIGNMENT</b>					
1.	12AD6 grid (pin 7) thru .1 mf capacitor and chassis	262.5 Kc	Hi end stop	2, 3 & 4	Adjust for <u>maximum</u> .
2.	"	"	"	1	Adjust for <u>minimum</u> . Adjust signal generator as required to obtain a well-defined minimum.
<b>RF ALIGNMENT</b>					
3.	Ant recept thru dummy	1610 Kc	Hi end stop	5, 6 & 7	Adjust for maximum.
4.	Ant recept thru dummy	1610 Kc	Hi end stop	5, 6 & 7	Adjust for maximum.
5.	"	1020 Kc	49/64" from hi end stop	8, 9 & 10	Adjust for maximum.
6.	"	1610 Kc	Hi end stop	5, 6 & 7	Adjust for maximum.
7.	Repeat steps 5 and 6 until no further increase; then cement cores in place. Step 6 should be last step.				
8.	Ant recept thru dummy	1525 Kc	1000 Kc	11	Adjust trap for minimum output of image frequency (1525 Kc) when tuned to 1000 Kc.
<b>ANTENNA TRIMMER</b>					
9.	-	-	Weak station around 1400 Kc	7	With radio in car and antenna fully extended, adjust antenna trimmer for maximum output.

**NOTE:** Do not perform steps 4, 5, 6, 7 and 8 unless tuner has been tampered with or components have been replaced. Remove escutcheon to expose core screws. Before proceeding with step 4, back tuning cores (of ant, RF & oscillator only) 1-3/8" out of coils to eliminate their effect on trimmer adjustments.

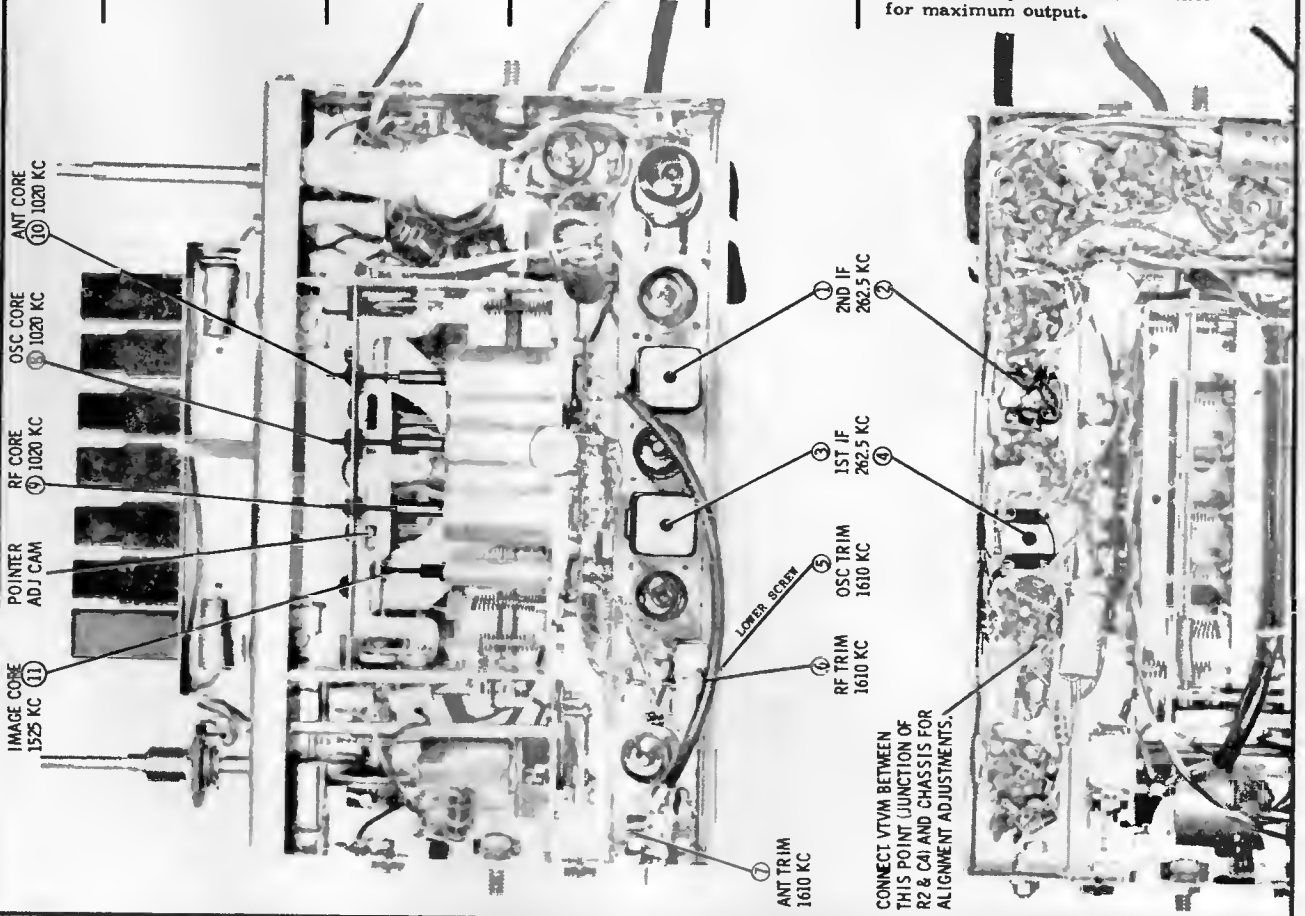

MODEL 918 ALIGNMENT ADJUSTMENTS

# MOTOROLA

MODELS	CHASSIS
56T1A	HS-553
56T1B	HS-554

These sets are very similar to Chassis HS-483, Model 56T1, covered on page 65, of the "Most-Often-Needed 1956 RADIO Diagrams" manual. In fact, Model 56T1B may be considered a later version of these earlier sets. In servicing, changes in 56T1B circuit may be followed to secure improved operation. For alignment trimmer locations refer to the prior volume mentioned.

Resistances measured with transistor out of associated circuit.  
 \*These capacitors may be built into the IF transformers on some sets.  
 †R19 value selected during production to adjust gain of set. Values from 68K to 120K may be used. Not used in all sets, however.

NOTES: Capacitors - Decimal values in MF, all others in MUF unless otherwise specified.  
 Voltages - Measured from point indicated to braided lead ground with a VTVM. No signal input, vol. at max tuning range - 550 to 1620 KC.  
 IF - 455 KC.

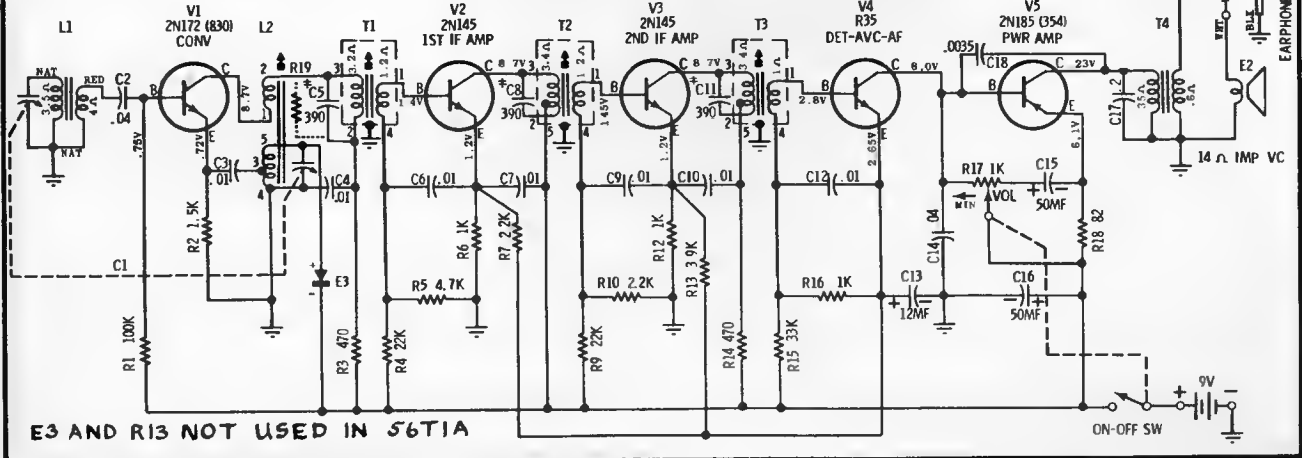
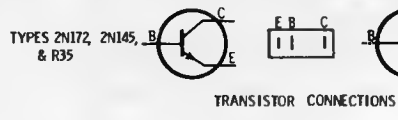
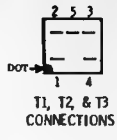
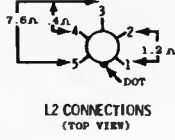
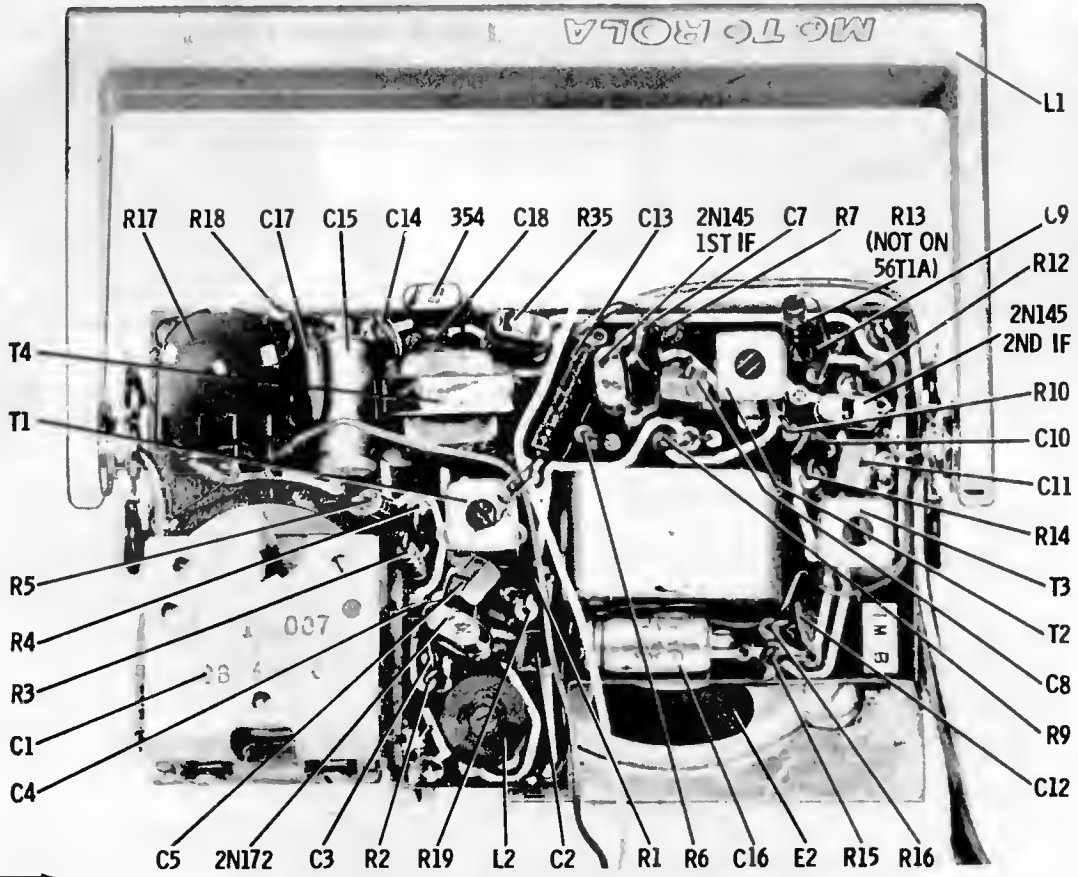

# MOTOROLA

RECORD CHANGER  
MODEL BR2RC  
PART NO 59D636270

## STYLUS RENEWAL

(Service material below and on the next eight pages.)

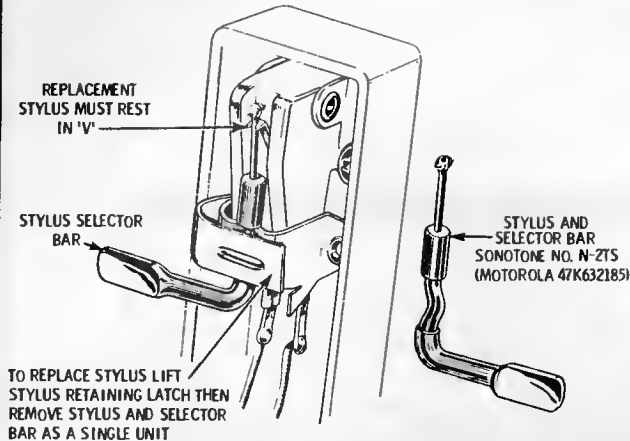

To renew a SONOTONE stylus, gently lift tone arm and lift stylus retaining latch, then remove stylus and selector bar as a single unit. When installing new stylus, be sure stylus rests in V. Replace with SONOTONE No. N-2TS (Motorola Part No. 47K632185).

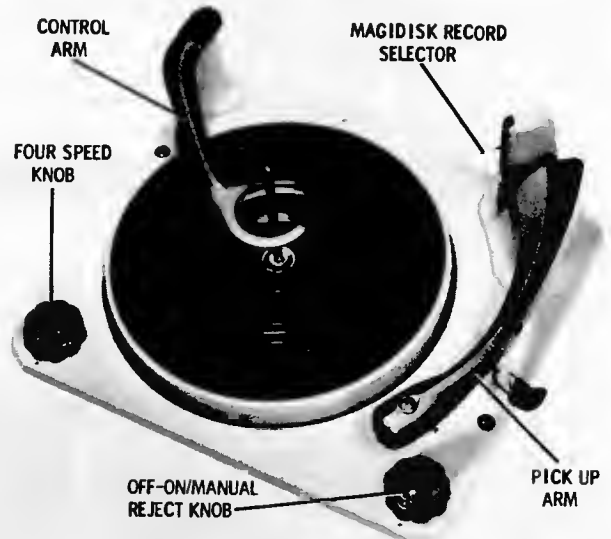

## OPERATING INSTRUCTIONS

This record changer will operate only on 117 volt 60 cycle AC.

**Loading.**--Lift the record control arm by holding it at the far end (i. e., end furthest away from the center spindle) and then swing it clear of the records. Then, taking each record singly, place it on the center spindle resting the first record on the spindle ledge. Hold the record in position with the left hand and load the others with the right hand in the same way. When all records are in position, replace the record control arm over the center spindle. If the records are all of one diameter, it may be more convenient to group the ten together; see that the center holes are all in line and place the group on the center spindle.

**Starting Up.**--Make sure that the pickup stylus is correct—that is, either 78 or 33-45 and similarly the speed knob. The Pickup is correctly set for 78 RPM records when knob at the front of the Pickup is so positioned that the number 78 (Std) is upright. To position the Pickup for long-playing records, the numbers 33-45 (LP) must be upright. Then move the On/Off/Manual/Reject Knob to the left firmly but not too roughly. That is all that is required.

**Rejecting.**--To reject a record, merely move the On/Off/Manual/Reject Knob to the LEFT.

When the last record is finished the machine will switch itself off automatically.

**Manual Operation.**--To play records singly on the record changer, the following procedure should be adopted: Place desired record on the turntable manually and replace control arm in its operating position. Turn On/Off/Manual/Reject switch to the "Manual" position only. The turntable will now revolve at the selected speed. Lift the Pickup off its rest and place in position on record. The record will now play and when completed the Pickup will return to rest and the unit will switch off automatically in the normal manner.

**To Remove the Records.**--Lift the record control arm and turn it out of the way. Grasp the records together and lift them gently from the center spindle, easing them past the ledge on the spindle.

After loading always see that the Magidisk Record Selector Arm (Item 8M139) is out and not stuck in a vertical position. In other words, it must be BELOW the records.

## GENERAL INFORMATION

This record changer is designed to play all of the existing types of phonograph records in common use. First, there is the record that rotates at a speed of 78 revolutions per minute. This type has been in common use for many years. Generally, this record is produced in two diameters, 10" and 12", playing respectively about 3-1/2 and 5 minutes per side. This record changer will play a total of ten records of average thickness at one loading, and the different diameters can be mixed; the machine itself will select the correct conditions for each diameter WITHOUT any adjustment. The only manual adjustment necessary is to turn the Pickup to the 78 position and rotate the speed control knob to the 78 position.

Secondly, there is the record that rotates at 33-1/3 revolutions per minute. This is commonly called the LP or long-playing type. It is generally produced in two diameters--12" and 10". The playing time is much longer per side than with the old 78 RPM type. Thus, one side of the 12" diameter can play up to 20 minutes. Again this record changer will accept a mixed loading of the different diameters and will automatically select the correct conditions for each. Again the only manual adjustments are the Pickup to the 33-1/3 position and the speed changer knob also to the 33-1/3 position.

Thirdly, there is the record that rotates at 45 revolutions per minute. This is only produced in the 7" diameter size. Some of these records are sold with a large center hole which must have an adaptor plate fitted to reduce the hole size to the common standard to fit the center spindle. The more recent tendency is to sell 45 RPM records with the standard small hole, allowing this center to be pushed out when the large hole is required. With these records the speed must be set to the 45 position and the Pickup set to the 33-1/3 position.

Fourthly, there is the record that rotates at 16-2/3 revolutions per minute. This is, at present, only produced in the 7" diameter size. Generally speaking, it is advisable to play these records singly. Some of these records are manufactured with a very large center hole. In such cases, they are sold with a special cardboard adaptor which reduces this hole to the standard size for normal use. Many records are, however, manufactured with the small standard center hole. With these records, set speed change knob to the 16-2/3 position and the Pickup to the 33-1/3 position.

**VOLUME R-17, MOST-OFTEN-NEEDED 1957 RADIO SERVICING INFORMATION**

**MOTOROLA Record Changer Model BR2RC Service Material, Continued**

**LUBRICATION**

A periodic check should be made to insure that your changer is lubricated adequately at the points detailed below:

Heavy grease should be used on the following points:

- (a) Main slide (Item 8M162), grease faces rubbed by cam (8M168), and also end of tongue.
- (b) Actuating lever (8M152), grease inside face of pawl resetting strip.
- (c) Reset arm (8M204), grease portion that rubs on cam gear (8M160).
- (d) Main sub-plate (8M169), grease guide slots.
- (e) Ballrace (8M68), fill ballrace cup with grease and assemble with open end upwards.
- (f) Four speed pawl (8M52), grease nose of pawl.
- (g) Speed change slide (8M44), grease location steps.

Light oil should be used on the following points:

- (a) Control spindle (8M4), oil spindle.
- (b) T. T. Bearing (8M63 and 8M65).
- (c) Rivet (8M135), oil sparingly taking care not to drip oil down on to plastic selector arm bearing (8M138).
- (d) Rivet (8M116).
- (e) Jockey pulley bearing (8M33).
- (f) Speed change slide (8M44), oil portion of mainplate over which slide moves.

**PLEASE NOTE**

No oil should be used on the Magidisk Record Selector Bearing (see Figure 7).

**ADJUSTMENTS**

**Needle Set-Down.** --The set-down position of the needle on the record is adjusted by manipulation of the needle adjusting screw (Item 8M261). (See Figure 4.) Adjust this screw until the correct set-down of the needle on a 10" record is obtained. The correct position is 1/8" from the edge of the record. It is advisable to make this adjustment with a stack of 10" records on the turntable. When correctly positioned for a 10" record, the 12" and 7" needle set-down will also be correct.

**Pickup Arm Height.** --The pickup arm height is adjusted by the pickup height adjusting screw (Item 8M257). (See Figure 4.) To raise the height of the pickup arm, turn this screw counterclockwise. To lower the pickup arm turn clockwise. The pickup height should be adjusted so that with a stack of ten average thickness records on the turntable, the point of the needle clears the top record by 1/16 inch. A check should then be made to insure that the pickup

arm clears the underside of records loaded on the center spindle.

**Needle Pressure.** --Adjustments may be made by repositioning the pickup balance spring (Item 8M263) in the various adjusting holes provided (see Figure 4) until the correct pressure is obtained.

**Adjusting of Speed Change.** --

- (1) Set the four speed knob at the 16-2/3 RPM position.
- (2) Slacken setscrews on the 4-speed pulley (Item 8M94) and adjust until the jockey pulley (Item 8M32) is engaged on the smallest pulley diameter just clear of the top step (see Figure 2).
- (3) Tighten setscrews.

**DISMANTLING**

- (1) Turntable Assembly (Item 8M62A)

Remove circlip (Item 8M109) and lift the turntable vertically upwards over the center spindle. Take care not to lose the thin thrust washer (that sticks to underside of turntable boss), ballrace of second thrust washer. NOTE: Before replacing assembly, set speed knob to 45 RPM. This allows easy maneuverability of jockey pulley when replacing turntable, without possible danger of bending jockey arm.

- (2) To Remove Control Arm Assembly (Item 8M2A) (See Figure 7)

Remove pin (Item 8M5) on underside of control arm spindle (Item 8M4) (See Figure 3).

- (3) Pickup Arm Assembly

This must be done after the changer has switched itself off. Unsolder the pickup leads from the connecting tagstrip. Un screw the pickup top bearing (see Figure 4) and then lift the pickup arm clear. Replace the pickup top bearing to avoid losing the spacer washer.

- (4) Main Sub-Assembly

Remove turntable and pickup arm as described and 3 screws (Items 8M114, 8M115 and 8M190) holding sub unit. Main sub-assembly can then be gently removed from unit-plate.

- (5) Sonotone 2TS Cartridge (from pickup arm)

Unscrew the two self-tapping screws securing the cartridge bracket to the arm moulding. Ease the two pickup lead tags from the lugs at the rear of the cartridge case.

**TROUBLE SHOOTING CHART**

SYMPTOMS	CAUSE	REMEDY
1. Turntable does not rotate when On/Off/Reject Knob is turned to "ON"	(1) No current to motor	(a) Check that current has reached record changer motor. (b) Check that switch box assembly is functioning correctly.
	(2) Motor defective	(c) Check all wiring and solder terminals to and from the switch box assembly (see Figure 1). (a) Remove the turntable and allow the motor to operate without load. If motor spindle is not rotating and voltage is reaching the motor, the motor is faulty. Repair or replace.
	(3) Jockey pulley not engaging turntable rim.	(b) Check that the 4-speed pulley (Figure 2) is not loose on motor spindle. If loose adjust as under "Adjustments of Speed Change". (a) Check that the jockey pulley is free to pivot. (b) Check that the jockey pulley spring is correctly positioned (see Figure 2).

MOTOROLA Record Changer Model BR2RC Service Material, Continued

TROUBLE CHART - Cont'd

SYMPTOMS	CAUSE	REMEDY
		(c) Carefully clean the inside rim of turntable and rubber tire on jockey pulley to insure that they are free from oil and grit.
II. Turntable revolves when On/Off/Reject Knob is turned to "ON" but pickup remains stationary on its rest.	(1) Incorrect manipulation of control.	Insure that the On/Off/Reject knob is turned to its fullest extremity in the "ON" direction. This does not apply when operating the changer manually.
III. Pickup lifts but fails to move in when record drops. The pickup returns to rest and the turntable continues to revolve	(1) Stop pin (Item 8M199)(see Figure 3) not dropping freely. (2) Adjusting link (Item BM20B) too tight (see Figure 3). (3) Stiffness in stop bracket assembly bearing (see Figure 3)	Remove all grease, oil, grit, burrs or rust carefully from the stop pin and spring (Item BM201) and insure that spring is not damaged. Slacken adjusting link by decreasing bend.  Free and lightly oil.

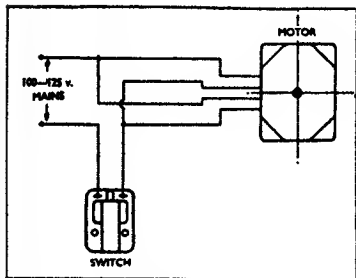

FIGURE 1.

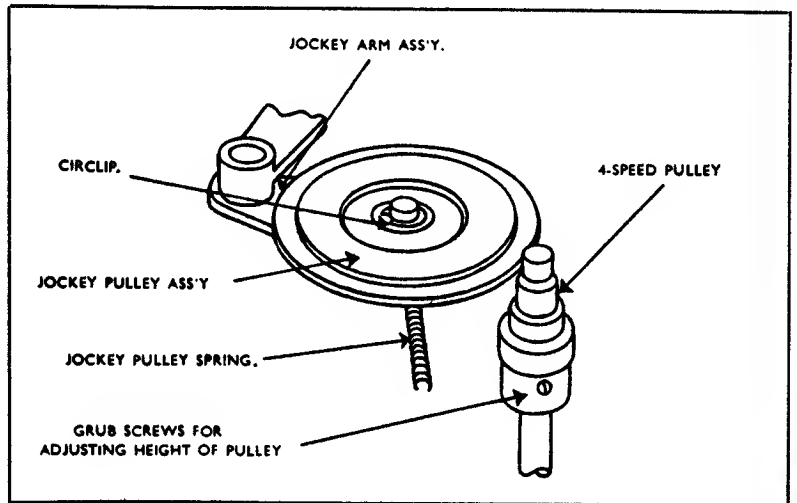

FIGURE 2.

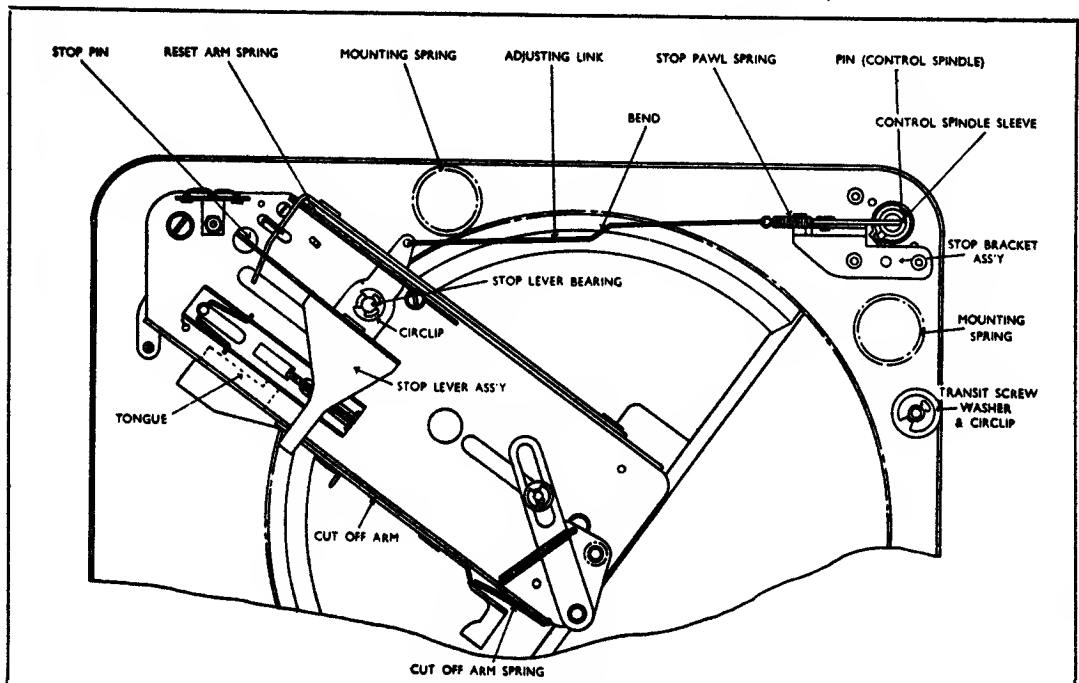

FIGURE 3.



VOLUME R-17, MOST-OFTEN-NEEDED 1957 RADIO SERVICING INFORMATION

TRUBLE CHART - Cont'd

SYMPTOMS	CAUSE	REMEDY
IV. Pickup lifts but fails to move in when record drops. Pickup returns to rest and changer switches off.	<ol style="list-style-type: none"> <li>(1) Cut off arm (Item 8M228) (see Figure 3) not returning to neutral position.</li> <li>(2) Undue friction at stop lever assembly bearing (see Figure 3)</li> <li>(3) Stiffness in stop bracket assembly bearing (see Figure 3)</li> </ol>	<ol style="list-style-type: none"> <li>(a) Cut off arm spring (Item 8M227) (see Figure 3) damaged. Replace.</li> <li>(b) Friction on moving surfaces of cut off arm. This lever must be absolutely free to slide in its slots. Check for rust, frays in slots, etc. Remove, clean and lightly oil.</li> </ol> <p>Free and lightly oil.</p>
V. Pickup arm strikes record on spindle when it rises or needle catches on last record when it moves out.	<ol style="list-style-type: none"> <li>(1) Pickup arm height not adjusted properly.</li> <li>(2) Control arm (Item 8M2) not holding records level.</li> <li>(3) Needle bent in crystal cartridge</li> </ol>	<p>See instructions for "Adjusting Pickup Arm Height" under "Adjustment".</p> <p>Hold control column securely and twist control arm until it will hold record stack parallel to top of turntable (see Figure 3).</p> <p>Replace needle. (See necessary instructions under "Dismantling".)</p>
VI. Turntable speed too slow.	<ol style="list-style-type: none"> <li>(1) Tightness in motor bearing.</li> <li>(2) Binding in turntable bearing.</li> <li>(3) Jockey pulley slip.</li> <li>(4) Input voltage too low</li> <li>(5) Operating temperature too low.</li> <li>(6) Undersized 4-speed pulley</li> </ol>	<p>Tap lightly the side of motor laminations to free self-aligning bearings.</p> <p>Check turntable bearing for freedom. If it does not turn easily when disengaged from the jockey pulley assembly (Item 8M32A) remove turntable, clean off foreign matter and lubricate with light mineral oil.</p> <p>Remove turntable and clean rim of jockey pulley. Oil jockey unit joints and pivots and make sure all move freely. Remove any trace of oil on jockey pulley rubber or inside of turntable rim.</p> <p>The input voltage should be not less than 100 volts. If the machine has been standing in a cold place or operated in surroundings at a temperature of less than 45°F. the turntable speed may be too slow initially.</p> <p>Remove turntable and fit new 4-speed pulley. Pulleys are available as follows: Small-red pulley; Medium-green pulley; Large-blue pulley. To increase turntable speed remove existing pulley from the motor shaft and fit the next size larger, or vice versa to reduce speed. When fitting new 4-speed pulley see "Adjustments of Speed Change" under "Adjustments".</p>
VII. Turntable speed too fast.	<ol style="list-style-type: none"> <li>(1) Input voltage too high.</li> <li>(2) Oversize 4-speed pulley.</li> </ol>	<p>Replace 4-speed pulley as instructed at "6" under "Turntable Speed Too Slow"</p>
VIII. Changer continues to cycle. With pickup dropping on to record during every cycle.	<ol style="list-style-type: none"> <li>(1) Pawl reset strip (see Figure 5) distorted.</li> <li>(2) Actuating pawl and friction link assembly (see Figure 5) too free.</li> </ol>	<p>Make sure that this strip is straight and resets friction link (Item 8M154) and actuating pawl (Item 8M156) by engaging with friction link shoulder during cycle (see Figure 5).</p> <p>Damp down the bearings of this assembly by smearing with medium grease.</p>
IX. Noise during playing of record.	<ol style="list-style-type: none"> <li>(1) Motor rumble.</li> <li>(2) Defective turntable bearing.</li> <li>(3) Defective jockey pulley.</li> <li>(4) Defective records</li> <li>(5) Squeaks</li> </ol>	<p>If a low pitched rumbling sound comes from the loudspeaker while the record is being played, check the motor rubber mountings to be sure the motor is freely suspended on them. The motor lead wires should have slack to allow the motor to float.</p> <p>Check for foreign matter in the bearings, defective balls, binding between balls, ball cage and thrust washers. Grease ballrace and washers. Lubricate with light mineral oil.</p> <p>A rapid thumping sound while the motor is running may indicate a flat on the motor jockey pulley (Item 8M32) (Figure 2). If this condition has not cleared up after 10 minutes of running time, remove the turntable and check the rubber tire on the jockey pulley. If the surface is not smooth, replace the jockey pulley. Should the bearings of the jockey assembly show signs of excessive wear, replace the jockey unit assembly.</p> <p>Worn or defective records cause needle scratch and distortion of the recorded sound. If the record is warped it may slip on the other records causing "wow". An enlarged hole in the record can also cause "wow". Squeaking sounds as the changer operates indicates a lack of oil. Lubricate.</p>
X. Distortion of recorded sound.	<ol style="list-style-type: none"> <li>(1) Defective record.</li> <li>(2) Defective amplifier.</li> <li>(3) Bad cartridge.</li> <li>(4) Dust on needle.</li> </ol>	<p>(See "4" under "Noise during playing of record.")</p> <p>Check both amplifier and speaker.</p> <p>Replace. (See instructions under "Dismantling".)</p> <p>Brush off dust with finger.</p>
XI. No sound during playing.	<ol style="list-style-type: none"> <li>(1) Defective cartridge.</li> <li>(2) Defective wiring.</li> <li>(3) Defective amplifier.</li> <li>(4) Loose cartridge socket tags.</li> </ol>	<p>Replace. (See instructions under "Dismantling".)</p> <p>Check pickup leads for short or open lead.</p> <p>Check amplifier and speaker.</p> <p>Remove, tighten slightly and replace.</p>

MOTOROLA Record Changer Model BR2RC Service Material, Continued

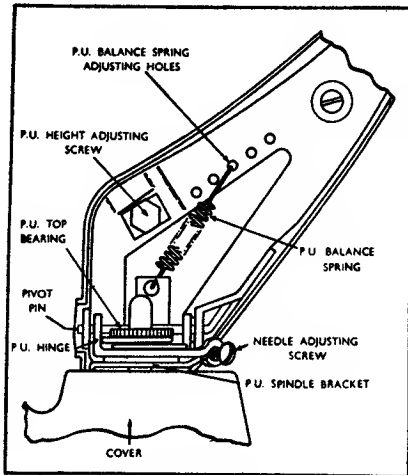

FIGURE 4.

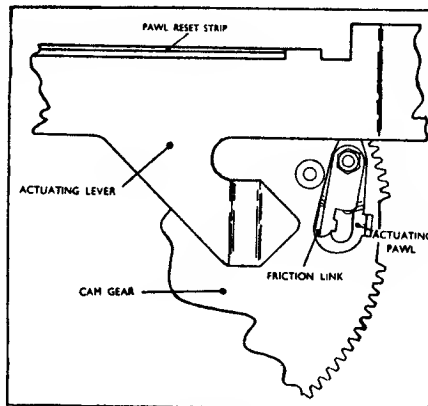

FIGURE 5.

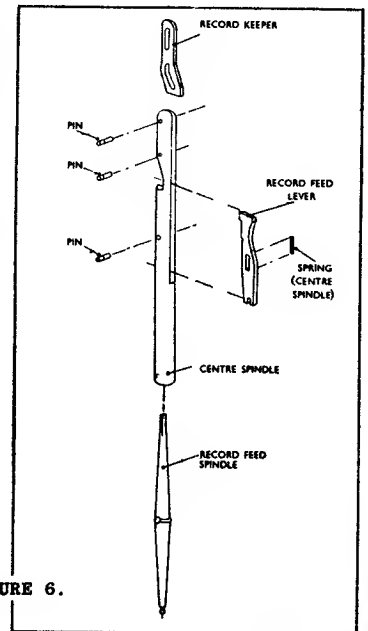

FIGURE 6.

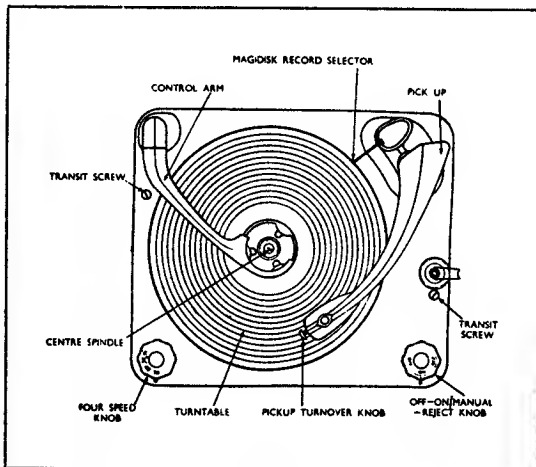

FIGURE 7.

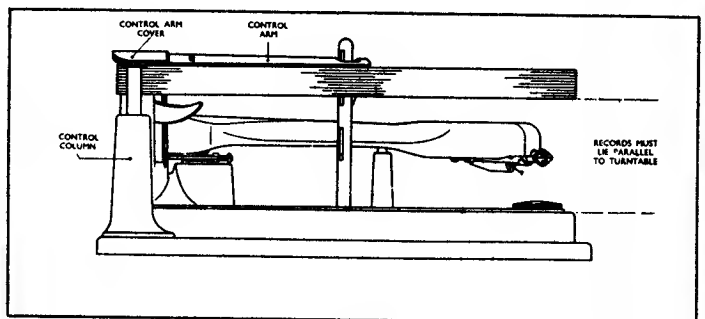

FIGURE 8.

TROUBLE CHART - Cont'd

SYMPTOMS	CAUSE	REMEDY
XII. Changer does not shut off after last record has been played, possibly continuing to play the last record from the 7" position.	(1) Control arm (Item 8M2) (Figure 8) binding. (2) Adjusting link (Item 8M208) broken, disconnected or too slack (see Figure 3). (3) Stop pawl spring (Item 8M17) loose, broken or faulty (see Figure 3). (4) Undue friction at stop lever assembly bearing (see Figure 3).	The record control arm must drop below the offset shoulder of the center spindle or the changer will not shut off. Replace or repair. } Tighten adjusting link by increasing bend. Replace or repair. } Remove, clean and lightly oil.
XIII. Changer returns pickup to rest before all records have been dropped. Turntable continues to revolve or changer switches itself completely off.	Adjusting link (Item 8M208) too tight (see Figure 3).	Slacken adjusting link by decreasing bend (see Figure 3)
XIV. 4-speed knob (Figure 7) does not select 16, 33, 45 or 78 when registering that speed.	Speed change wrongly adjusted.	Refer to "Adjustments of Speed Change" under "Adjustments".
XV. Record does not drop when changer cycles.	(1) Record feed spindle (Item 8M107) (Figure 6) broken. (2) Record feed lever (Item 8M104) (Figure 6) broken.	Replace record feed spindle or complete center spindle. Replace record feed lever or the complete center spindle.

VOLUME R-17, MOST-OFTEN-NEEDED 1957 RADIO SERVICING INFORMATION

MOTOROLA Record Changer Model BR2RC Service Material, Continued

TROUBLE CHART - Cont'd

SYMPTOMS	CAUSE	REMEDY
XVI. Two records drop at once.	<ol style="list-style-type: none"> <li>(1) Hole in record too large.</li> <li>(2) Record keeper (Item 8M100) (Figure 6) not fully down.</li> <li>(3) The record control arm (Item 8M2) not holding records level.</li> </ol>	<p>Replace record. Carefully clean and remove burrs. Do not oil. It should fall under its own weight. Refer to Figure 8. Hold control column securely and twist control arm until it will hold record stack parallel to top face of turntable.</p>
XVII. P. U. does not locate correctly on records.	<ol style="list-style-type: none"> <li>(1) Rubber buffer (Item 8M240) missing or misplaced at rear of P. U. arm.</li> <li>(2) Pickup arm not adjusted properly.</li> <li>(3) Needle bent.</li> </ol>	<p>Replace rubber buffer (Item 8M240) in small hole in the side of the P. U. arm just behind the hinge. Slip eyelet (8M239) over stem of rubber inside arm and clamp tightly. See "Needle Set-Down" under "Adjustments".</p> <p>Replace with new needle. (See necessary instructions under "Stylus Renewal".</p>
XVIII. Pickup remains on record run-out groove, or on last groove.	<ol style="list-style-type: none"> <li>(1) No finishing run-out groove on record.</li> <li>(2) Needle jumps out of groove in record.</li> <li>(3) Faulty actuating pawl and friction link (see Figure 5).</li> </ol>	<p>Check record for eccentric run-out groove in center of record. Some old records and home recordings do not have this eccentric run-out groove.</p> <ol style="list-style-type: none"> <li>(a) Check that needle pressure is correct -should be 8-10 grams.</li> <li>(b) Check that the record is not defective -the run-out groove is often too shallow.</li> <li>(c) The needle point might be damaged or affected by excessive accumulation of dust. Replace or clean.</li> <li>(d) There may be binding in the pickup spindle bracket (Item 8M182 and Items 8M173 and 8M181). Insure that all moving parts are free and lightly oiled.</li> </ol> <p>When friction link has been moved towards center of gear wheel and then slowly pushed outwards, it should also carry the actuating pawl outwards from the start of its movement. If the pawl does not move freely with the link, it will not engage the turntable boss to start cycle. Dismantle link and pawl, clean, reassemble and oil. Take care with tiny spring between the two parts.</p>
XIX. Pickup does not move in when set down on record.	No run in groove on record.	Check that the record is of the standard type which has a run-in groove from the outside edge of the record to the recorded section. Some old type records and home recordings do not have this run-in groove.
XX. Needle does not track across record properly.	<ol style="list-style-type: none"> <li>(1) Needle may be clogged with an accumulation of dust or be worn.</li> <li>(2) Pickup leads too tight.</li> <li>(3) Changer not level.</li> <li>(4) Binding or friction in the pickup spindle bracket assembly. (Figure 4)</li> <li>(5) Needle pressure insufficient.</li> <li>(6) Actuating lever (Item 8M152) (Figure 5) not free on slide.</li> <li>(7) Pickup hinge fouling pickup cover (Figure 4).</li> <li>(8) Worn records or records with damaged groove.</li> <li>(9) Pickup spindle bracket (Item 8M182) fouling tongue on stop plate (8M185) in down position of pickup spindle bracket.</li> </ol>	<ol style="list-style-type: none"> <li>(a) Clean the foreign material from around the needle.</li> <li>(b) Check needle to see if the tip is broken or bent and replace if necessary. (To replace see necessary instructions under "Dismantling".</li> </ol> <p>Give the pickup leads enough slack to allow the tone arm to move freely across the record. Insure that the changer is level before use. Insure that all moving parts and bearing surfaces in this assembly are free and lightly oil.</p> <p>Check as under "Adjustments". This lever must be absolutely free to slide in slots. Check for bending, rust, frays in slots, etc. Bend hinge up to clear.</p> <p>Replace record.</p> <ol style="list-style-type: none"> <li>(a) Clear dirt.</li> <li>(b) Bend tongue to clear.</li> </ol>
XXI. Pickup does not locate on pickup rest	Tongue on stop plate (Item 8M185) not locating in pickup spindle bracket (Item 8M182) due to pin (8M164) being out of line.	Adjust pin (8M164) by bending arm of main slide pressing so that the tongue on (Item 8M185) will slip into the notch on (Item 8M182) when the radial faces of the two pressings are against the pin.
XXII. Turntable slips or stalls.	<ol style="list-style-type: none"> <li>(1) 4-speed knob not set in correct position.</li> <li>(2) 4-speed knob in neutral.</li> <li>(3) Jockey pulley slipping.</li> <li>(4) Insufficient tension on jockey pulley spring (8M48).</li> </ol>	<p>Move knob slightly to allow pawl (8M52) to fall into notch in slide. Set on correct speed. Remove turntable and carefully clean all traces of oil off inside of arm, off jockey pulley tire, and off 4 step pulley. Replace spring.</p>

MOTOROLA Record Changer Model BR2RC Service Material, Continued

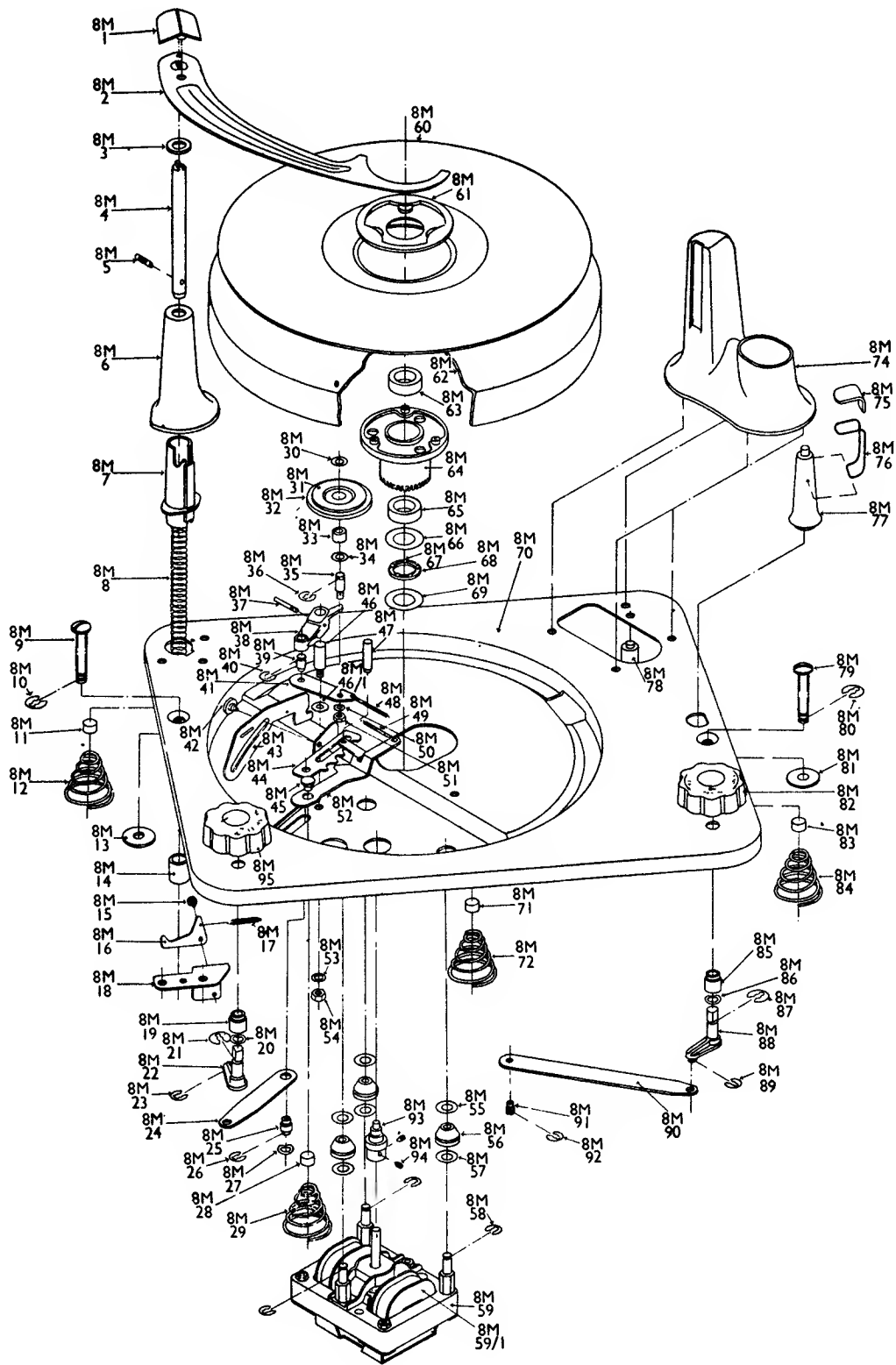

MAINPLATE ASSEMBLY

FIGURE 9.

VOLUME R-17, MOST-OFTEN-NEEDED 1957 RADIO SERVICING INFORMATION

MOTOROLA Record Changer Model BR2RC Service Material, Continued

REPLACEMENT PARTS LIST

Ref. No.	Part Number	Description	Ref. No.	Part Number	Description
8M2A	1K837028	Control Arm Assem (incl 8M1, 8M2, 8M4)	8M114	3K837082	No. 8 x 1/4" S.T. Screw
8M3	4K837027	Felt Washer	8M115	3K837082	No. 8 x 1/4" S.T. Screw
8M5	22K837028	Pin (Control Spindle)	8M118A	7K837083	Latch Plate Assem (incl 8M118, 8M119)
8M8	41K837029	Spring (Control Column)	8M120A	7K837084	Support Brkt Assem (incl 8M118, 8M117, 8M18A, 8M120, 8M121, 8M122)
8M9	3K837030	Transit Screw (mounts with 8M10 circlip)	8M123	41K837085	Spring (Latch Plate)
-	3K837070	Transit Screw (mounts with hair-clip)	8M122	3K837088	Screw 4 B.A. x 1/4" Hex
8M10	4K837031	Circlip	8M124	4K837058	4 B.A. Lockwasher
8M13	4K837032	Washer (Unit Mtg)	8M132A	40K837087	Switch Box Assem (incl 8M125, 8M128, 8M127, 8M128, 8M129, 8M130, 8M131, 8M132, 8M133, 8M134)
8M14	43K837033	Control Spindle Sleeve	8M138A	1K837088	Selector Column Assem (incl 8M138, 8M137A, 8M141, 8M142, 8M143, 8M144, 8M145, 8M147, 8M148)
8M17	41K837034	Spring (Stop Pawl)	8M137A	1K837089	Trip Arm Assem & Rivet (incl 8M135, 8M137, 8M138, 8M139, 8M140)
8M18A	1K837035	Stop Brkt Assem (incl 8M15, 8M18, 8M18)	8M148	41K837090	Spring (Tracking)
8M20	4K837038	Spring Washer	8M149	2K837087	4 B.A. Full Nut
8M21	4K837037	Circlip	8M150	4K837058	4 B.A. Lockwasher
8M22	40K837038	Switch Reject Arm	8M151	3K837091	Screw 4 B.A. x 3/8" R.H.
8M23	4K837037	Circlip	8M152	45K837092	Actuating Lever
8M24	45K837039	Speed Change Link	8M153	2K837093	8 B.A. Locknut
8M28	4K837037	Circlip	8M154	45K837094	Friction Link
8M27	4K837040	Spring Washer	8M155	41K837095	Actuating Pressure Spring
8M30	4K837041	J.P. Spindle Washer	8M158	45K837098	Actuating Pawl
8M31A	1K837042	Jockey Unit Assem (incl 8M30, 8M32A, 8M34, 8M35, 8M38, 8M38A, 8M40, 8M41A, 8M50, 8M51)	8M160A	44K837097	Cam Gear Assem (incl 8M153, 8M154, 8M155, 8M158, 8M156, 8M159, 8M160, 8M161, 8M188)
8M32	49K837043	Jockey Pulley Tyre	8M181	45K837098	Actuating pivot
8M32A	1K637044	Jockey Pulley Assem (incl 8M31, 8M32, 8M33)	8M188	4K837099	Washer
8M34	4K837041	J.P. Spindle Washer	8M187	4K837037	Circlip
8M35	47K837045	J.P. Spindle	8M189A	1K837100	Main Sub Plate Riveting Assem (incl 8M108, 8M112, 8M113, 8M120A, 8M189, 8M170, 8M172, 8M187, 8M197, 8M203, 8M204, 8M205, 8M212A, 8M220, 8M222, 8M228, 8M229, 8M230)
8M38	4K837037	Circlip	8M171	4K837037	Circlip
8M38A	1K837048	Speed Change Lever Assem (incl 8M37, 8M38)	8M173	45K837101	P.U. Top Bearing
8M40	4K837037	Circlip	8M174	41K837102	Spring (P.U. Overload)
8M41A	1K837047	Jockey Arm Assem (incl 8M39, 8M41)	8M175	4K837103	Washer
8M44A	1K837048	Speed Change Slide Assem (incl 8M25, 8M42, 8M43, 8M44)	8M178	41K837104	Spring (Gate Actuating)
8M48	4K837049	Speed Change Pivot	8M177	4K837105	Circlip
8M48/1	4K837050	Washer	8M178	4K837105	2 B.A. Plain Washer
8M48	41K837051	Spring (Jockey Arm)	8M179	41K837107	Spring (P.U. Raising)
8M49	41K837052	Spring (4-Speed Pawl)	8M180	4K837108	Circlip
8M50	4K837053	8 B.A. Lockwasher	8M181	43K837109	P.U. Bottom Bearing
8M51	2K837054	8 B.A. Half Nut	8M182A	7K837110	P.U. Spindle Brkt Assem (incl 8M182, 8M183)
8M52A	1K837055	4-Speed Pawl Assem & Rivet (incl 8M45, 8M47, 8M52)	8M185A	64K837111	Stop Plate Assem (incl 8M184, 8M185)
8M53	4K837058	4 B.A. Lockwasher	8M188	41K837112	Spring (P.U. Return)
8M54	2K837057	4 B.A. Full Nut	8M188	3K837091	Screw 4 B.A. x 3/8" R.H.
8M55	4K837058	Washer (Motor Mtg)(3)	8M189	4K837113	2 B.A. Lockwasher
8M58	5K837059	Rubber Mtg (3)	8M190	3K837114	Screw 2 B.A. x 1/4" R.M.
8M57	4K837058	Washer (Motor Mtg)(3)	8M191	4K837058	4 B.A. Lockwasher
8M58	4K837037	Circlip	8M192	31K837115	Tag Mtg Strip
8M59	59K837080	F.P. 10 D Motor (117 volt, 80 cycle AC)	8M193	2K837057	4 B.A. Full Nut
8M80	75K837081	Turntable Mat	8M194A	47K837118	P.U. Spindle Assem (incl 8M194, 8M195)
8M62A	1K837082	Turntable Assem (incl 8M81, 8M82, 8M83, 8M84, 8M85)	8M198	41K837117	Spring (T.8. Return)
8M88	4K837083	Thrust Washer	8M198	7K837118	Toggle Slide
8M68A	4K837084	Ballrace & Thrust Washers (incl 8M88, 8M87, 8M88, 8M89)	8M199	22K837119	Stop Pin
8M89	4K837083	Thrust Washer	8M200	4K837120	Circlip
8M75	15K837088	P.U. Clip Cover	8M201	41K837121	Spring (Stop Pin)
8M78	42K837087	P.U. Clip	8M202	41K837122	Spring (Reset Arm)
8M79	3K837030	Transit Screw (mounts with 8M80 circlip)	8M208	4K837123	Washer
-	3K837070	Transit Screw (mounts with hair-pin clip)	8M207	3K837082	No. 8 x 1/4" S.T. Screw
8M80	4K837031	Circlip	8M208	45K837124	Adjusting Link
8M81	4K837032	Washer (Unit Mtg)	8M209	4K837125	Spacer Washer
8M82	38K837088	Reject Knob	8M210	4K837037	Circlip
8M88	4K837038	Spring Washer	8M211	4K837125	Spacer Washer
8M87	4K837037	Circlip	8M212A	84K837128	Record Feed Plate Assem & Rivet (incl 8M212, 8M213, 8M214, 8M218)
8M88	40K837038	Switch Reject Arm	8M215	4K837037	Circlip
8M89	4K837037	Circlip	8M218	41K837127	Spring
8M90A	1K837089	Reject Link Assem (incl 8M90, 8M91)	8M217	4K837125	Spacer Washer
8M92	4K837037	Circlip	8M219	4K837037	Circlip
8M93A-8R	49K837071	4-Speed Pulley Assem: small (red) incl set screws - 80 cycle	8M221	4K837128	Circlip
8M93A-8PG	49K837072	4-Speed Pulley Assem: nominal (green or no color) incl set screws - 60 cycle	8M224A	1K837129	Stop Lever Assem (incl 8M223, 8M224, 8M225, 8M228)
8M93A-8B	49K837073	4-Speed Pulley Assem: large (blue) incl set screws - 60 cycle	8M227	41K837130	Spring (Cut Off Arm)
8M93A-8R	49K837158	4-Speed Pulley Assem: small (red) incl set screws - 50 cycle	8M239	5K837131	Eyelet
8M83A-8PG	49K837157	4-Speed Pulley Assem: nominal (green or no color) incl set screws - 50 cycle	8M240	48K837132	Rubber Stop
8M93A-8B	49K837158	4-Speed Pulley Assem: large (blue) incl set screws - 50 cycle	8M241	45K837133	P.U. Arm
8M94	3K837074	Set Screw 4 B.A. x 3/18" (2)	8M241A	45K837134	P.U. Arm Assem (incl 8M239, 8M240, 8M241, 8M242, 8M244, 8M245, 8M246, 8M247, 8M248, 8M249, 8M250, 8M251, 8M252, 8M253, 8M254, 8M255, 8M258, 8M257, 8M258, 8M259, 8M280, 8M261, 8M282A, 8M263, 8M284, 8M285)
8M95	38K837075	4-Speed Knob	8M242	49K837135	Disc Label
8M100	42K837078	Record Keeper	8M248	30K837138	P.U. Lead (18")
8M108A	47K837077	Center Spindle Assem (incl 8M100, 8M101, 8M102, 8M103, 8M104, 8M105, 8M108, 8M107)	8M249	37K837137	3 mm PVC Bleeding (4")
8M107	47K837078	Record Feed Spindle	8M250	84K837138	Damping Weight Plate
8M109	4K837079	Circlip (T.T. Bearing)	8M251	42K837139	Spire Fix (S.F.R. 1041/17/00)
8M110	3K837080	Set Screw (4 B.A. x 3/32")	8M252	5K837140	Rubber Grommet (P.B.C.G. 42)
8M111	3K837081	Shouldered Screw	8M253	3K837141	No. 4 x 3/8" S.T. Screw
			8M254	5K837140	Rubber Grommet (P.B.C.G. 42)
			8M255	3K837141	No. 4 x 3/8" S.T. Screw

MOTOROLA Record Changer

Model BR2RC Service Material, Continued

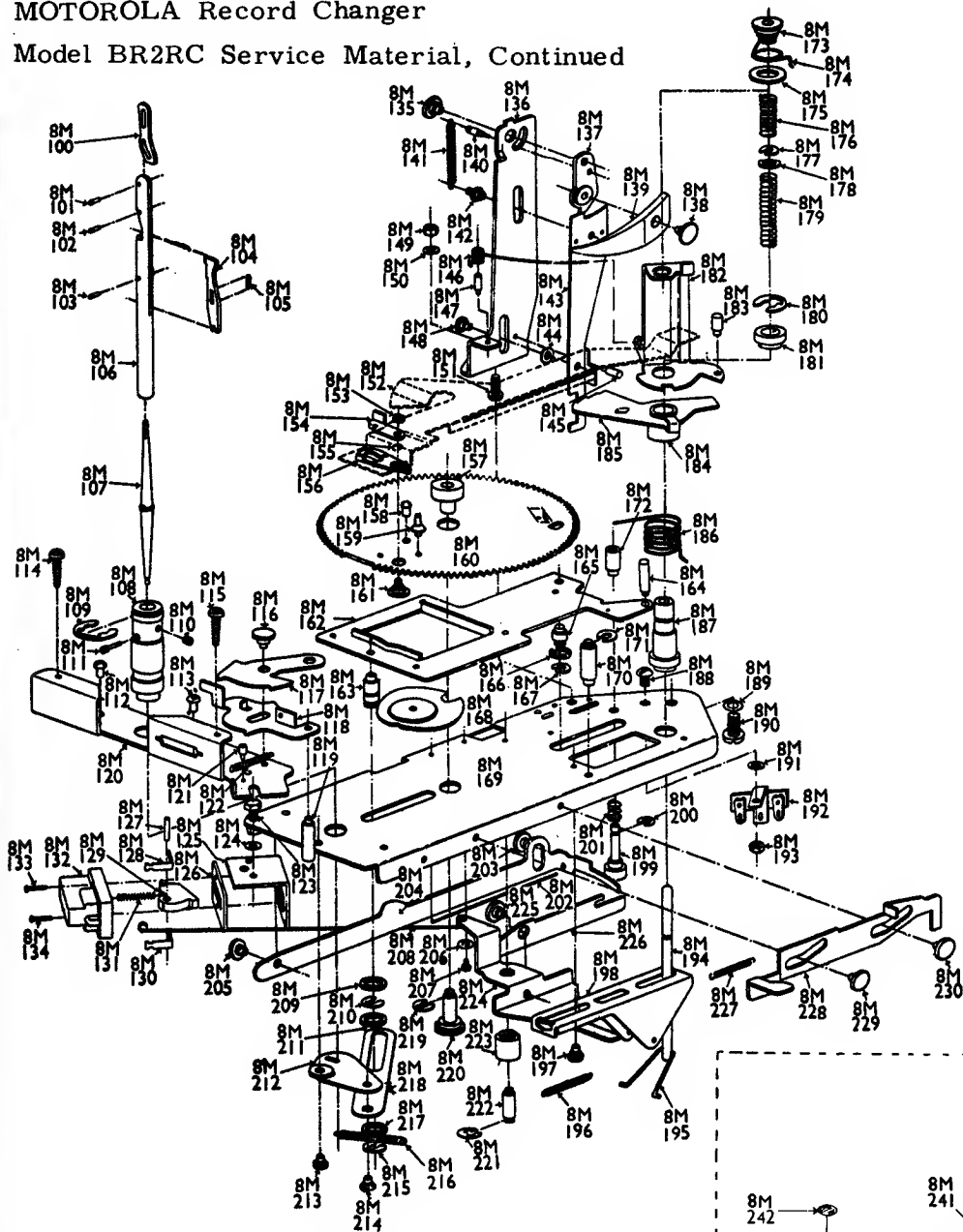

MAIN SUB PLATE

FIGURE 10.

Ref. No.	Part Number	Description
8M256	42K637142	Spire Flat Nut (S.N.P. 1301/17/0)
8M257	3K637143	P.U. Height Adj. Screw.....
8M258	7K637144	P.U. Support Bracket.....
8M259	5K637140	Rubber Grommet (P.B.C.G. 42)
8M260	3K637141	No. 4 x 3/8" S.T. Screw.....
8M261	3K637145	6 B.A. x 3/8" R.H. Screw.....
8M262A	55K637146	P.U. Hinge Assem (incl 8M262, 8M264).....
8M263	41K637147	Spring (P.U. Balance).....
8M265	22K637148	Pivot Pin.....
-	59B634441	Cartridge, Sonotone 2TS (incl stylus).....
-	47K632185	Stylus, Sonotone M-2TS (dual sapphire).....
-	47K636271	Spindle, 45RPM.....
-	3K637149	Screw, cartridge mtg: No. 4 x 7/16" S.T.....
-	43K637150	Bushing, cartridge mtg.....
-	39K637191	Cartridge Contact.....

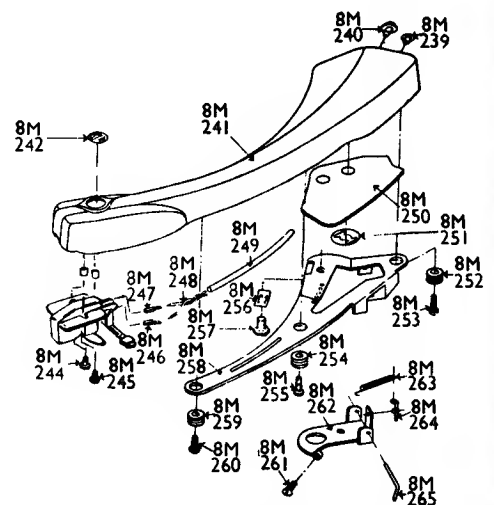

PICKUP ARM ASSEMBLY

FIGURE 11.

# OLYMPIC RADIO & TELEVISION INC.

## MODEL 404

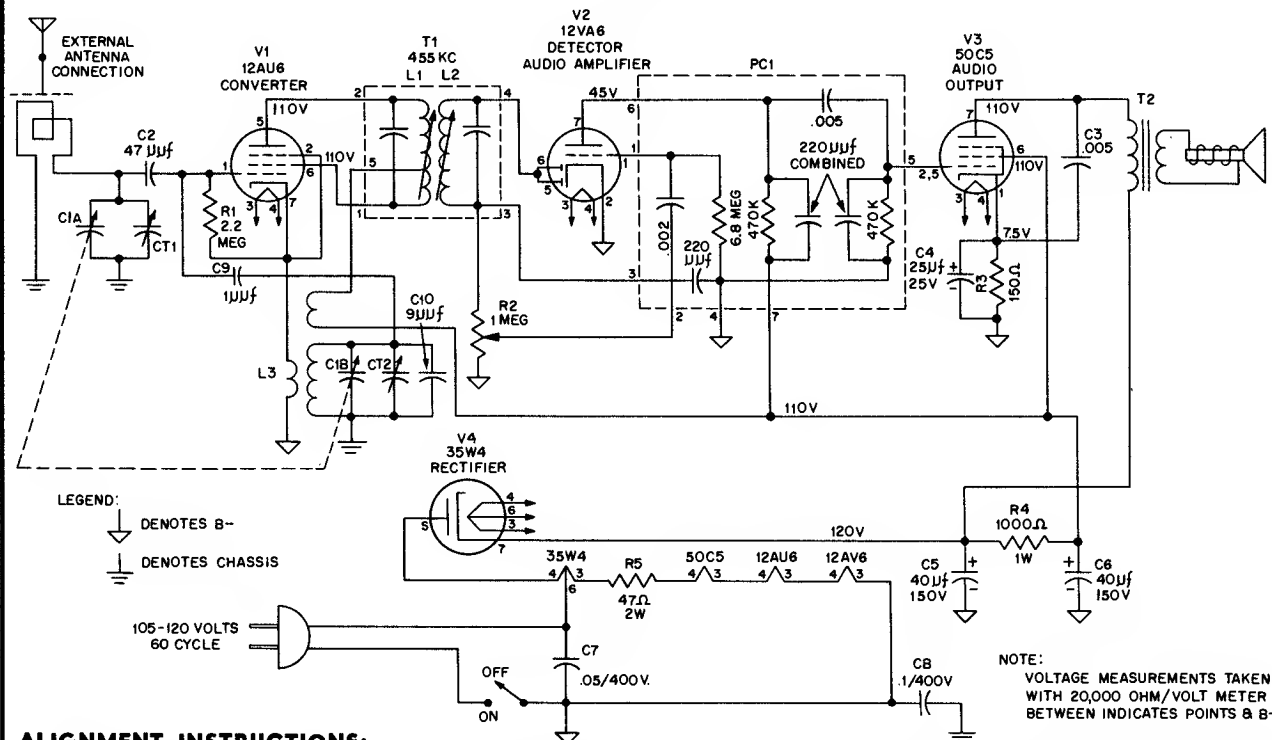

### ALIGNMENT INSTRUCTIONS:

The chassis must be removed from the cabinet before alignment can be performed. Before removing the chassis pull off the two knobs, one on each side of the cabinet. At the rear of the cabinet, remove the four screws which hold the antenna loop back to the cabinet. Then remove the three screws which hold the chassis to the cabinet. The chassis can then be easily removed.

Equipment required: Modulated RF signal generator; output meter; insulated screw-driver, two .1 mfd 600 volt condensers. To insure proper alignment, a radiated signal will be required during part of the alignment procedure. To radiate a signal, connect a loop of about 6 inches in diameter (one turn of #14 or #12 wire) across the output of the signal generator, and place this loop parallel to the loop of the receiver to be aligned, at a distance of about 10 or 12 inches.

Connect the output meter and signal generator as follows:

Output meter: Connect across the speaker voice coil and turn the volume control to maximum (extreme clockwise position).

Signal generator: When the generator is not used to radiate a signal, connect the low side to the receiver chassis through a .1 mfd condenser, clip the high side through a .1 mfd, 600 volt condenser to the point at which signal injection is required, and keep the output as low as possible. Proceed in the sequence shown in the alignment chart.

When the alignment process is completed, turn the tuning knob shaft until the tuning condenser plates are fully meshed. Replace the chassis inside the cabinet, insert and tighten the screws previously removed, and mount each knob on its shaft at the side of the cabinet. With the condenser plates fully meshed, place the tuning knob on its shaft so that the horizontal line at the "55" end of the knob is adjacent to the indicating marker on the cabinet.

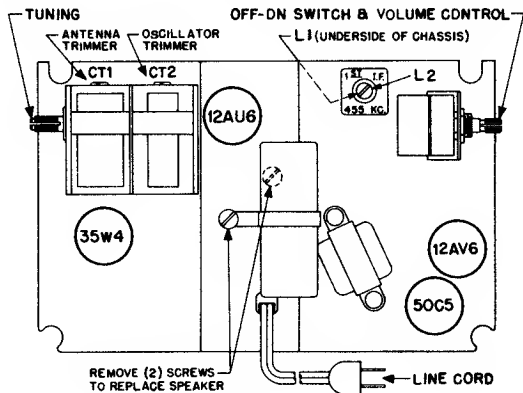

ALIGNMENT PROCEDURE CHART

STEP	CONNECT HIGH SIDE OF SIGNAL GENERATOR TO-	SET SIGNAL GENERATOR TO-	TURN RECEIVER DIAL TO-	ADJUST THE FOLLOWING FOR MAXIMUM OUTPUT. (KEEP SIGNAL FROM SIGNAL GENERATOR AS LOW AS POSSIBLE.)
1	ANTENNA SECTION	455 KC.	FULL COUNTER-CLOCKWISE POSITION (CONDENSER PLATES FULLY OPEN)	L2 AND L1 IN SAME ORDER (I.F. TRANSFORMER)
2	USE RADIATED SIGNAL	1620 KC.	MAXIMUM SIGNAL APPROX 1500 KC.	CT2 (OSCILLATOR TRIMMER)
3		1500 KC.		CT1 (ANTENNA TRIMMER)
4	REPEAT STEPS 2 AND 3			

**Frequency Range: 540-1620 KC**

**Power Requirement: 105-120 volts alternating current 60 cycles, or 105-120 volts direct current.**

**Power Consumption: 25 watts.**

OLYMPIC RADIO & TELEVISION INC.

MODEL 407

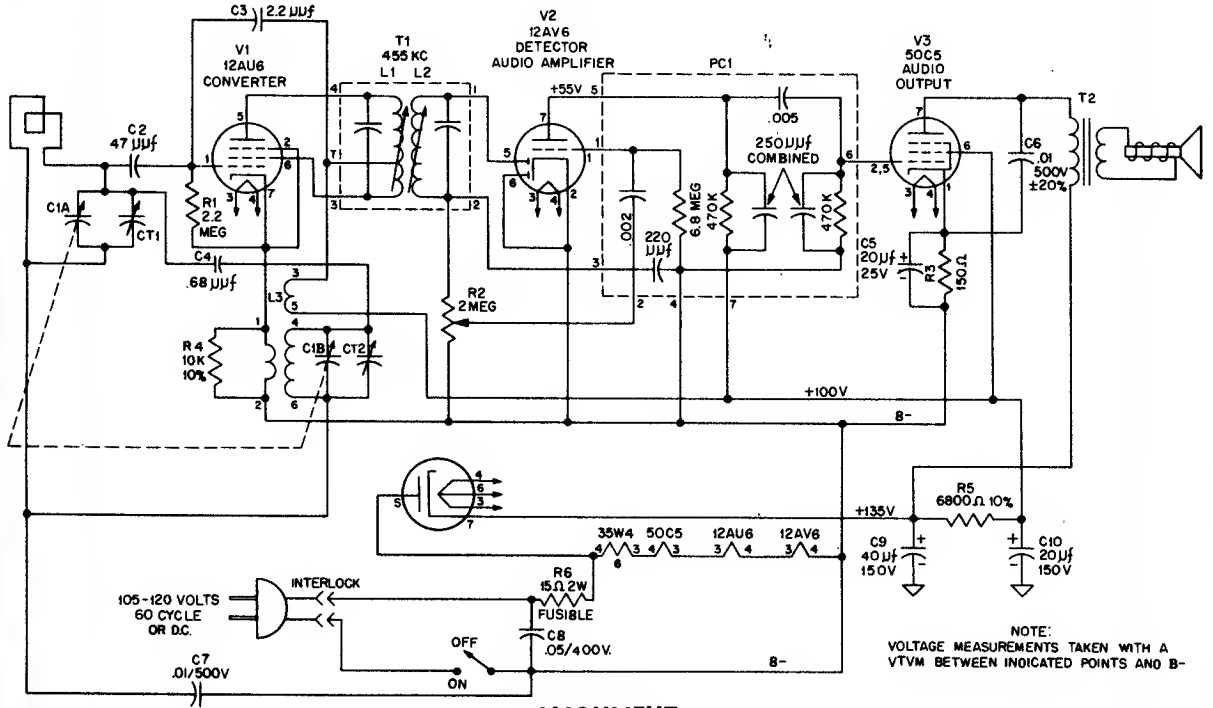

ALIGNMENT

The chassis must be removed from the cabinet before alignment can be performed. To remove chassis, 1) remove the cabinet back with loop antenna and line cord, 2) pull the two knobs off the front of the cabinet, 3) unscrew the one screw located behind the tuning knob from the front of the cabinet, 4) slide the chassis out of the cabinet.

Equipment required: Modulated RF signal generator; output meter; insulated screw-driver, two .1 mfd 600 volt condensers.

To insure proper alignment, a radiated signal will be required during part of the alignment procedure. To radiate a signal, connect a loop of about 6 inches in diameter (one turn of #14 or #12 wire) across the output of the signal generator, and place this loop parallel to the loop of the receiver to be aligned, at a distance of about 10 or 12 inches.

Connect the output meter and signal generator as follows:

Output meter: Connect across the speaker voice coil and turn the volume control to maximum (extreme clockwise position).

Signal generator: When the generator is not used to radiate a signal, connect the low side to the receiver chassis through a .1 mfd condenser, clip the high side through a .1 mfd, 600 volt condenser to the point at which signal injection is required, and keep the output as low as possible. Proceed in the sequence shown in the alignment chart.

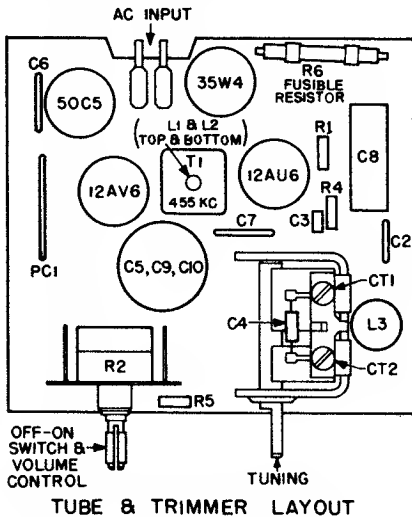

ALIGNMENT PROCEDURE CHART

STEP	CONNECT HIGH SIDE OF SIGNAL GENERATOR TO-	SET SIGNAL GENERATOR TO-	TURN RECEIVER DIAL TO-	ADJUST THE FOLLOWING FOR MAXIMUM OUTPUT (KEEP SIGNAL FROM SIGNAL GENERATOR AS LOW AS POSSIBLE.)
1	ANTENNA SECTION TUNING CONDENSER IN SERIES WITH .1MFD COND.	455 KC.	FULL, COUNTER-CLOCKWISE POSITION. (CONDENSER PLATES FULLY OPEN)	L2 AND L1 IN SAME ORDER (I.F. TRANSFORMER)
2	USE RADIATED SIGNAL	1620 KC.	MAXIMUM SIGNAL APPROX 1500 KC.	CT2 (OSCILLATOR TRIMMER)
3		1500 KC.		CT1 (ANTENNA TRIMMER)
4	REPEAT STEPS 2 AND 3			

REF. NO.	DESCRIPTION	PART NO.
L3	Oscillator Coil	CL4291
PC1	Printed Circuit	PC4388
R1	Resistor, 2.2 megohms ± 20%, 1/2w	REB225M
R2	Volume Control, 2 megohms (with switch)	PT4397
R3	Resistor, 150 ohms ± 20%, 1/2w	REB151M
R4	Resistor, 10,000 ohms ± 10%, 1/2w	REB103K
R5	Resistor, 6800 ohms ± 10%, 1/2w	REB682K
R6	Resistor, 15 ohms, 2w, Fusible	RE4393
T1	Transformer, 1F (455 kc)	TR4392



**OLYMPIC RADIO MODEL NUMBER 446**

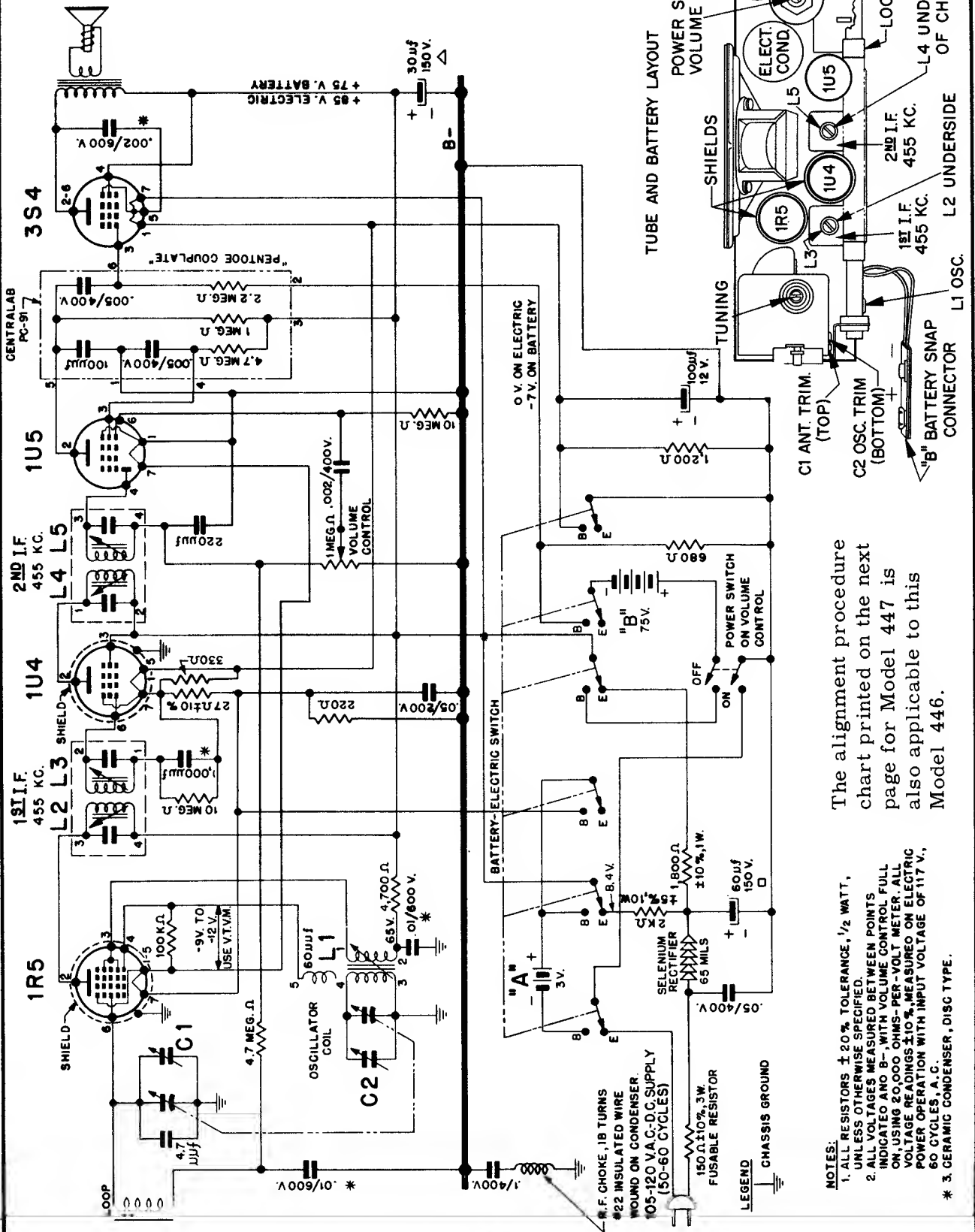

The alignment procedure chart printed on the next page for Model 447 is also applicable to this Model 446.

- NOTES:**
1. ALL RESISTORS ±20% TOLERANCE, 1/2 WATT, UNLESS OTHERWISE SPECIFIED.
  2. ALL VOLTAGES MEASURED BETWEEN POINTS INDICATED AND "B" WITH VOLUME CONTROL FULL ON, USING 20,000 OHMS-PER-VOLT METER. ALL VOLTAGE READINGS ±10% MEASURED ON ELECTRIC POWER OPERATION WITH INPUT VOLTAGE OF 117 V., 60 CYCLES, A.C.
  - \* 3. CERAMIC CONDENSER, DISC TYPE.

OLYMPIC RADIO MODEL NUMBER 447

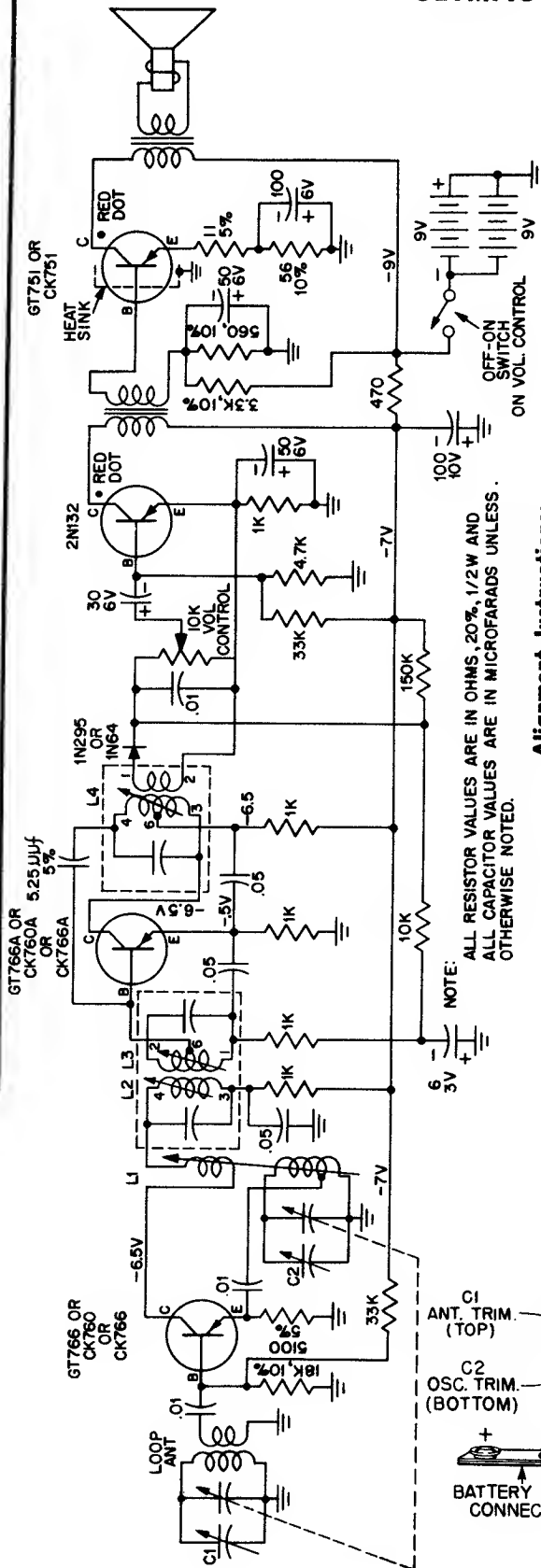

Alignment instructions:

Equipment required: Modulated RF signal generator; output meter; insulated screw-driver. two .1 mfd 400 volt condensers.

To insure proper alignment, a radiated signal will be required during part of the alignment procedure. To radiate a signal, connect a loop of about 6 inches in diameter (one turn of #14 or #12 wire) across the output of the signal generator, and place this loop parallel to the loop of the receiver to be aligned, at a distance of about 10 or 12 inches. Connect the output meter and signal generator as follows:

Output meter: Connect across the speaker voice coil and turn the volume control to maximum (extreme clockwise position).

Signal generator: When the generator is not used to radiate a signal, connect the low side to the receiver chassis through a .1 mfd condenser, clip the high side to the point at which signal injection is required, and keep the output as low as possible. Proceed in the sequence shown in the alignment chart.

ALIGNMENT PROCEDURE CHART

STEP	CONNECT HIGH SIDE OF SIGNAL GENERATOR TO-	SET SIGNAL GENERATOR TO-	SET DIAL KNOB CALIBRATION TO (ALIGN WITH LINE ON CABINET)	ADJUST THE FOLLOWING FOR MAXIMUM OUTPUT (KEEP SIGNAL FROM SIGNAL GENERATOR AS LOW AS POSSIBLE)
1	R F SECTION OF VARIABLE CONDENSER IN SERIES WITH A .1MFD. 400 VOLT CONDENSER.	455 KC.	EXTREME CLOCKWISE POSITION (CONDENSER PLATES FULLY OPEN)	L4, L3, L2 AND REPEAT IN SAME ORDER (1st. AND 2nd. I.F. TRANSFORMERS.)
2	USE RADIATED SIGNAL	1600 KC.	1600 KC. (16 ON KNOB)	C2 (OSCILLATOR TRIMMER)
3	CONNECT BOTH SIDES OF SIGNAL GENERATOR TO RADIATION LOOP)	1400 KC.	MAXIMUM SIGNAL (APPROX. 14 ON KNOB)	C1 (ANTENNA TRIMMER)
4		600 KC.	MAXIMUM SIGNAL (APPROX. 6 ON KNOB)	ADJUST L1 (ROCK VARIABLE FOR MAXIMUM SIGNAL.)
5	REPEAT STEPS 2, 3 & 4 AT LEAST TWICE TO INSURE MAXIMUM SENSITIVITY & PROPER DIAL TRACKING			

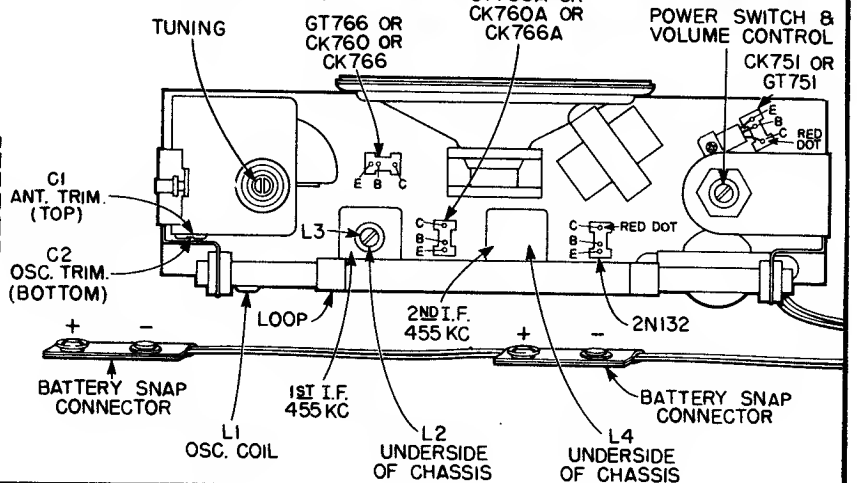

# Packard Bell

## MODEL 4RB1 PORTABLE BATTERY RADIO

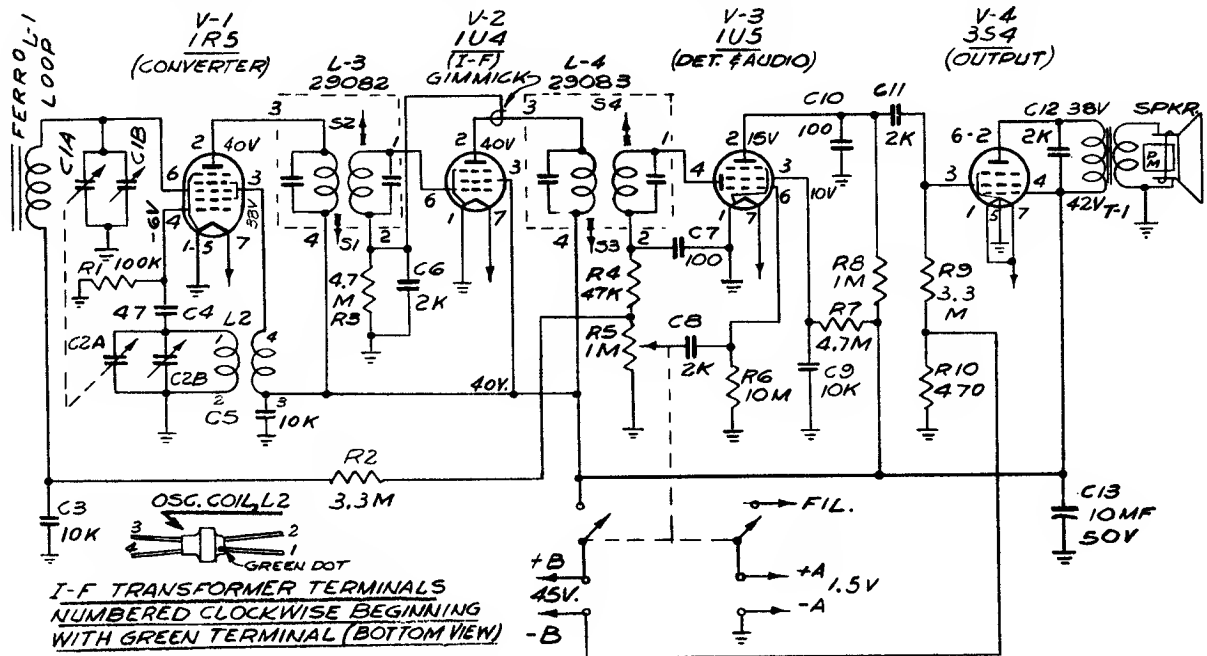

### ALIGNMENT PROCEDURE:

Alignment is accomplished by following the steps in the chart below. Connect output meter to speaker voice coil. Connect test oscillator through a .01 mfd capacitor to pin 6 (grid 3) of V-1 for the first step. Ground lead of generator goes to chassis. For steps two and three, couple generator loosely to ferroloop with three or four turns of wire. Each adjustment should be made using a minimum input signal.

STEP	CONNECT TEST OSCILLATOR TO	TEST OSCILLATOR FREQUENCY	RADIO DIAL SETTING	ADJUST
1.	Pin 6, V-1 (1R5)	455 kc	535 kc	S-1, S-2, S-3, & S-4 for MAX.
2.	Couple to loop	1620 kc	1620 kc	C-2B for MAX.
3.	Couple to loop	1500 kc	Tune to test osc. signal	C-1B for MAX.

### REFERENCE SYMBOL

REFERENCE SYMBOL	DESCRIPTION	PACKARD-BELL PART NUMBER
<b>CAPACITORS</b>		
C-1 (A & B)	Variable, 2-gang with trimmers	23548
C-2 (A & B)	Ceramic, 10,000 mmf, GMV (3/8 in. diameter)	23862
C-3	Ceramic, 47 mmf, 20%	23912
C-4	Same as C-3	
C-5	Ceramic, 2000 mmf, 20% (3/8 in. diameter)	23839
C-6	Same as C-3	
C-7	Ceramic, 100 mmf, 20%	23914
C-8	Same as C-6	
C-9	Same as C-3	
C-10	Same as C-7	
C-11	Same as C-6	
C-12	Same as C-6	
C-13	Electrolytic, 10 mfd, 50 volt	24123

### RESISTORS

All resistors one-quarter (1/4) watt.

R-1	100,000 ohms, 20%	73949
R-2	3.3 megohms, 20%	73967
R-3	4.7 megohms, 20%	73969
R-4	47,000 ohms, 10%	73845
R-5	Variable control, volume with switch, 1 megohm	25041A
R-6	10 megohms, 20%	73973
R-7	Same as R-3	
R-8	1 megohm, 20%	73961
R-9	Same as R-2	
R-10	470 ohms, 10%	73821

### INDUCTANCES

L-1	Ferro-loop antenna	29354
L-2	Oscillator coil	29232
L-3	First I-F coil	29082
L-4	Second I-F coil	29083

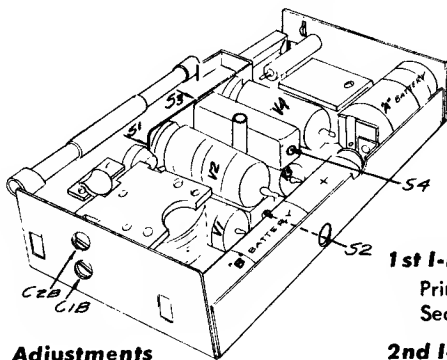

### Adjustments

**Oscillator Coil:**  
Primary, 2.6 ohms  
Secondary, 13 ohms

**1st I-F Coil:**  
Primary, 44 ohms  
Secondary, 44 ohms

**2nd I-F Coil:**  
Primary, 44 ohms  
Secondary, 44 ohms

**Ferroloop antenna:**  
3.6 ohms

Packard-Bell

MODEL 5R1  
TABLE MODEL RADIO

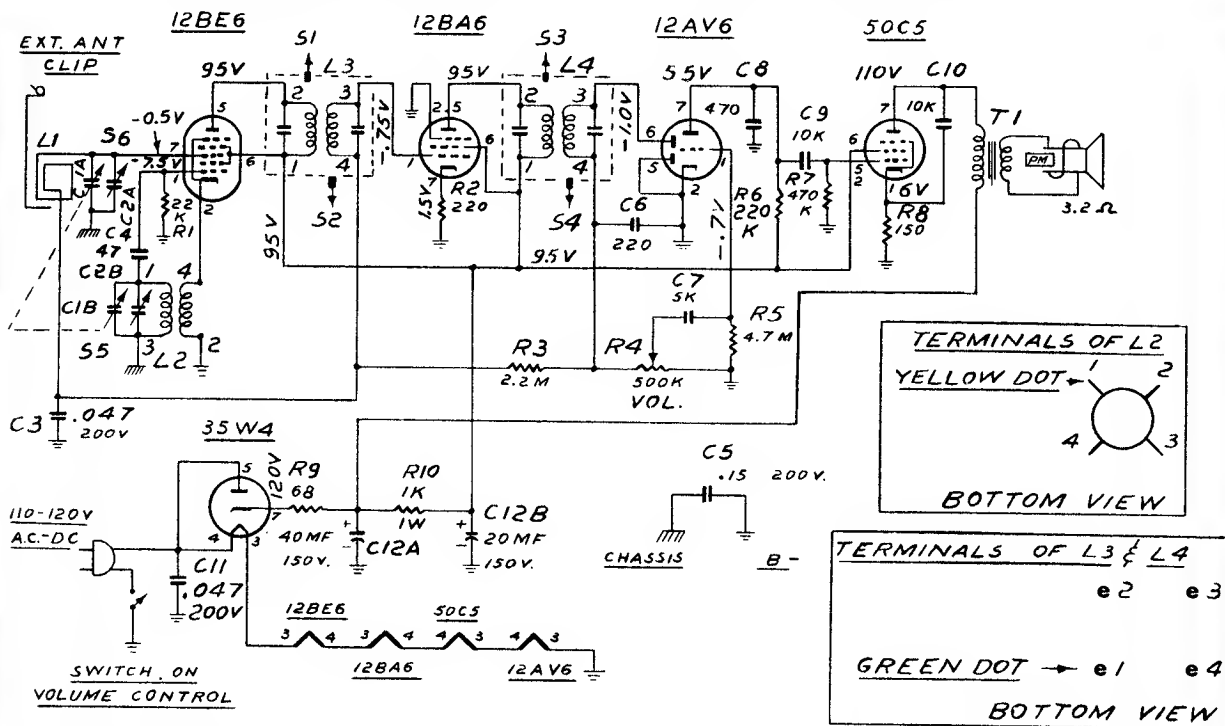

**ALIGNMENT PROCEDURE:**

The alignment of the set is accomplished by following the steps in the chart below. Connect output meter to speaker voice coil. Use isolation transformer, if available, for shock protection.

Each adjustment should be made using a minimum input signal. Connect test oscillator through a .01 mfd capacitor to the point indicated below. Ground lead of oscillator is connected to B minus bus.

STEP	CONNECT TEST OSCILLATOR TO	TEST OSCILLATOR FREQUENCY	RADIO DIAL SETTING	ADJUST
1.	Pin 1, V-1 (12BE6)	455 Kc.	540 Kc.	S-1, S-2, S-3, & S-4 for MAX.
2.	Antenna Clip	1620 Kc.	1620 Kc.	S-5 for MAX.
3.	Antenna Clip	1500 Kc.	Tune to Osc. Signal	S-6 for MAX.

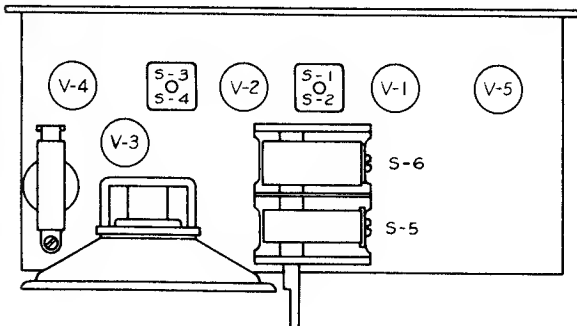

**Socket voltages measured as follows:**

1. Line voltage, 117 volts AC.
2. Volume control at maximum.
3. VTVM between socket terminal and B minus bus.
4. Only DC voltages measured. Allow 10% tolerance.

**SPECIAL SERVICING INFORMATION:**

**DC RESISTANCE MEASUREMENTS:**

**1st I-F Coil:**

Primary, 12 ohms  
Secondary, 13 ohms

**2nd I-F Coil:**

Primary, 13 ohms  
Secondary, 13 ohms

**Oscillator Coil:**

Primary, 1 ohm  
Secondary, 5.5 ohms

**Loop Antenna:**

Resistance, 1 ohm

**OSCILLATOR CATHODE VOLTAGES:**

(Measured using AC vacuum tube voltmeter with an input impedance of more than 10 megohms. Line voltage 117 volts AC.)

- 1500 Kc. 2.6 volts AC (rms)
- 1000 Kc. 2.3 volts AC
- 750 Kc. 2.1 volts
- 540 Kc. 2.0 volts

# PHILCO

## PHILCO MODEL: C-5690(HR)

(Philco material in this manual is reproduced through the courtesy of the Philco Corp.)

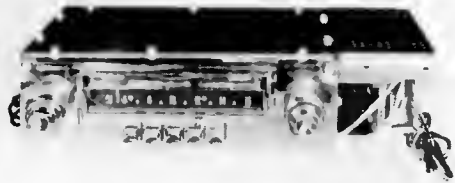
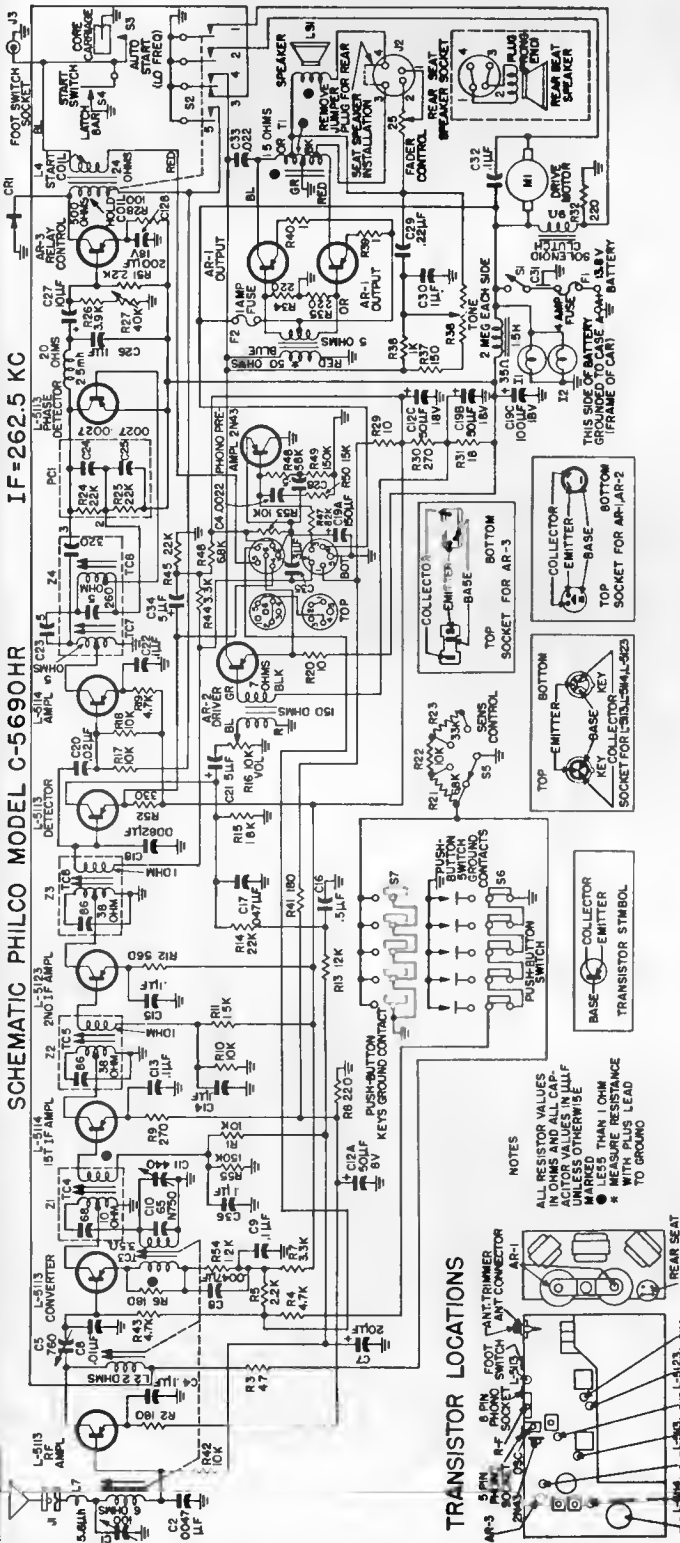

### RELAY CURRENT ADJUSTMENT

If the relay control transistor, AR-3, is defective and needs replacement the 40,000 ohm relay control bias potentiometer, R27, must be adjusted as follows:

Connect a milliammeter between contact 5 of relay S2 and ground, and adjust the relay control bias pot, R27, until 13 milliamperes is indicated on the meter.

### SERVICE HINTS

1. All units are wired for connection with NEGATIVE GROUND. If the set is connected backwards, the motor will drive in reverse (from high frequency end to low frequency end) and the 1 ampere fuse will blow out.
2. If the motor is reversed or the latching pawl is accidentally tripped before tuning reaches the high frequency end, a number of clockwise revolutions of the manual tuning knob may be required to again engage the cam.
3. Where a set is dead or inoperative, first check the radio in the car to make sure there are jumpers in the rear seat speaker, and phono. sockets. See figure 3.
4. When soldering any transistor lug, turn the set off and remove the transistor. To prevent any damage to the transistor from any AC leakage from the soldering iron.
5. CAUTION: Do not ground the base of any of the transistors or serious damage will result to the transistor.

### CIRCUIT CHANGES

- Resistor R55 was changed from 150,000 ohms to 220,000 ohms, part No. 66-4228340.
- Resistor R45 was changed from 22,000 ohms to 82,000 ohms, part No. 66-3828340.
- A 47-ohm, 1/2-watt resistor, part No. 66-0478340, was added between emitter detector transistor L-5113 and the junction of R52
- C35 A .1-ufd capacitor, part No. 30-1260, was added between the emitter of Detector Transistor L-5113 and ground.
- Resistor R15, was changed from 1.8K to 2.7K ± 10%, part No. 66-2278340.
- Resistor R29 was changed from 10 ohm ± 5% to 8.2 ohms ± 5%, part No. 66-9823260.
- Resistor R23 was changed from 33,000 ohms to 10,000 ohms, part No. 66-1038340.

# PHILCO AUTO RADIO

MODEL M-5741

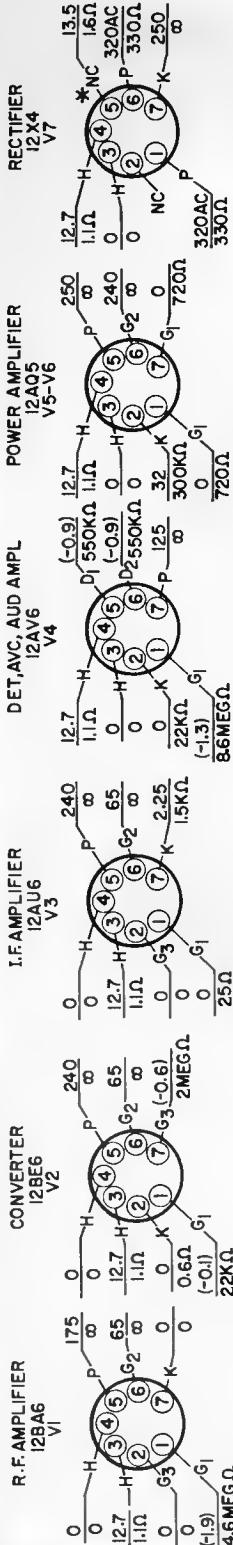
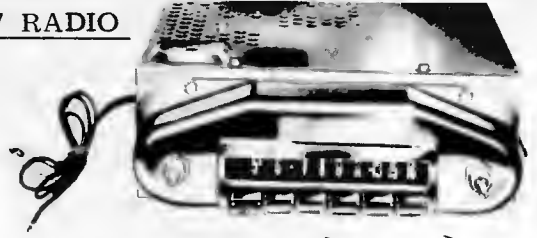

⊗ LESS THAN 1 OHM

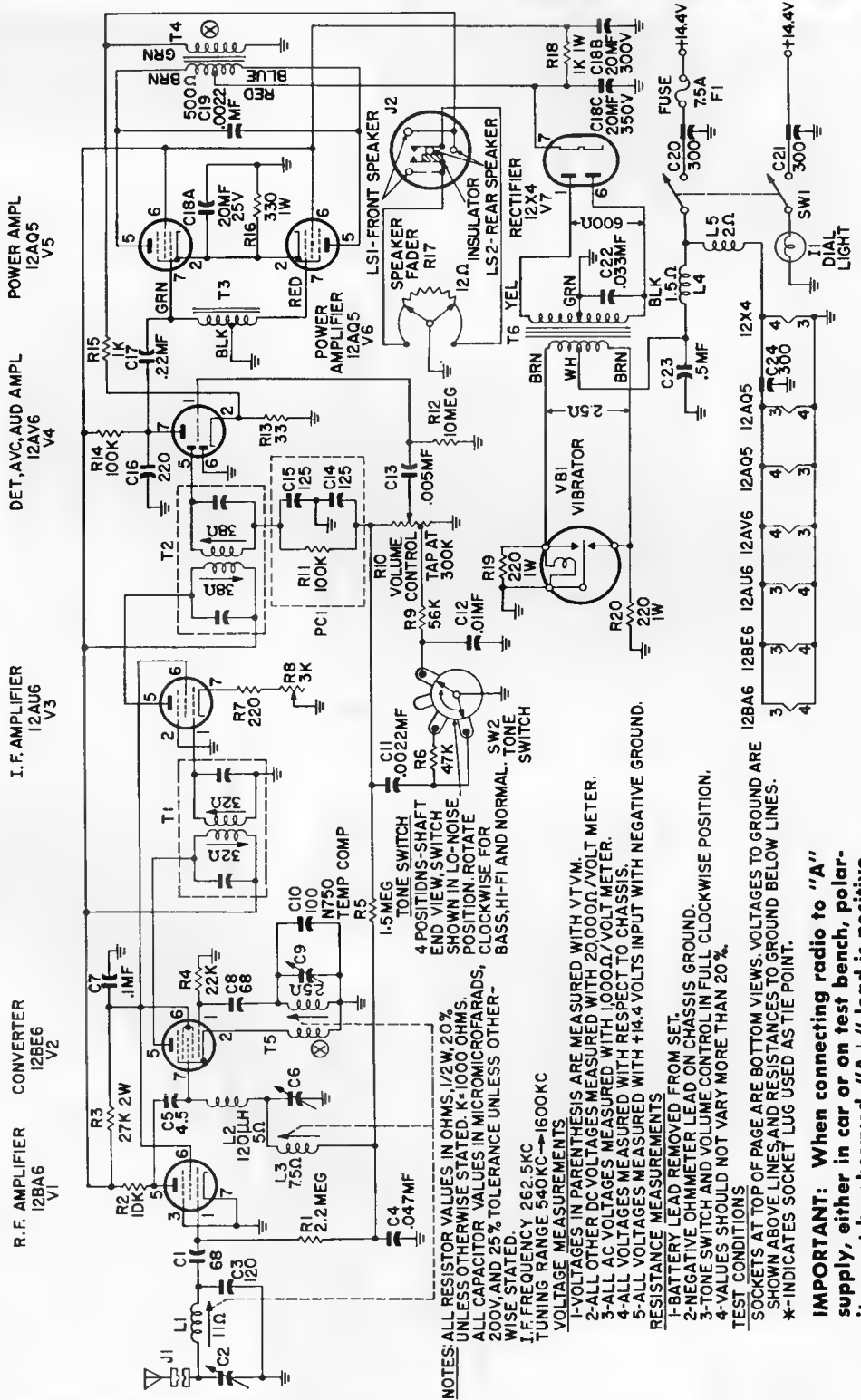

**NOTES:**  
 ALL RESISTOR VALUES IN OHMS, 1/2W, 20% UNLESS OTHERWISE STATED. K=1000 OHMS. ALL CAPACITOR VALUES IN MICROMICROFARADS, 200V, AND 25% TOLERANCE UNLESS OTHERWISE STATED.  
 I.F. FREQUENCY 262.5 KC  
 TUNING RANGE 540KC→1600KC  
**VOLTAGE MEASUREMENTS**  
 1-VOLTAGES IN PARENTHESES ARE MEASURED WITH VTVM.  
 2-ALL OTHER DC VOLTAGES MEASURED WITH 20,000Ω/VOLT METER.  
 3-ALL AC VOLTAGES MEASURED WITH 1,000Ω/VOLT METER.  
 4-ALL VOLTAGES MEASURED WITH RESPECT TO CHASSIS.  
 5-ALL VOLTAGES MEASURED WITH +14.4 VOLTS INPUT WITH NEGATIVE GROUND.  
**RESISTANCE MEASUREMENTS**  
 1-BATTERY LEAD REMOVED, FROM SET.  
 2-NEGATIVE OHMMETER LEAD ON CHASSIS GROUND.  
 3-TONE SWITCH AND VOLUME CONTROL IN FULL CLOCKWISE POSITION.  
 4-VALUES SHOULD NOT VARY MORE THAN 20%.  
**TEST CONDITIONS**  
 SOCKETS AT TOP OF PAGE ARE BOTTOM VIEWS. VOLTAGES TO GROUND ARE SHOWN ABOVE LINES AND RESISTANCES TO GROUND BELOW LINES.  
 \*-INDICATES SOCKET LUG USED AS TIE POINT.

**IMPORTANT:** When connecting radio to "A" supply, either in car or on test bench, polarity must be observed. "A+" lead is positive, "A-" is chassis ground.

# PHILCO

## E-670, E-672, E-675 AND E-676



### ALIGNMENT PROCEDURE

**General**—Allow set and test equipment to warm up for fifteen minutes before starting the alignment.

**Dial Indicator**—Before alignment, the dial knob should be set as follows: with the condenser gang plates fully meshed, the indicator on knob should be pointing straight up.

**Output Indicator**—Connect a 1000-ohms-per-volt a-c voltmeter or an oscilloscope across the voice-coil terminals.

**Signal Generator**—Use an AM r-f signal generator. Connect the ground lead to B—, and connect the output lead as indicated in the alignment chart.

**Output Level**—Attenuate the signal-generator output throughout the alignment so as to maintain the output below .4 volts.

**Radio Controls**—Set the volume control to maximum. Set the tuning control as indicated in the alignment chart. It is recommended that a-c power be used when aligning the radio.

**Note:** Insulated shield around 1U4 must be in place to eliminate oscillation.

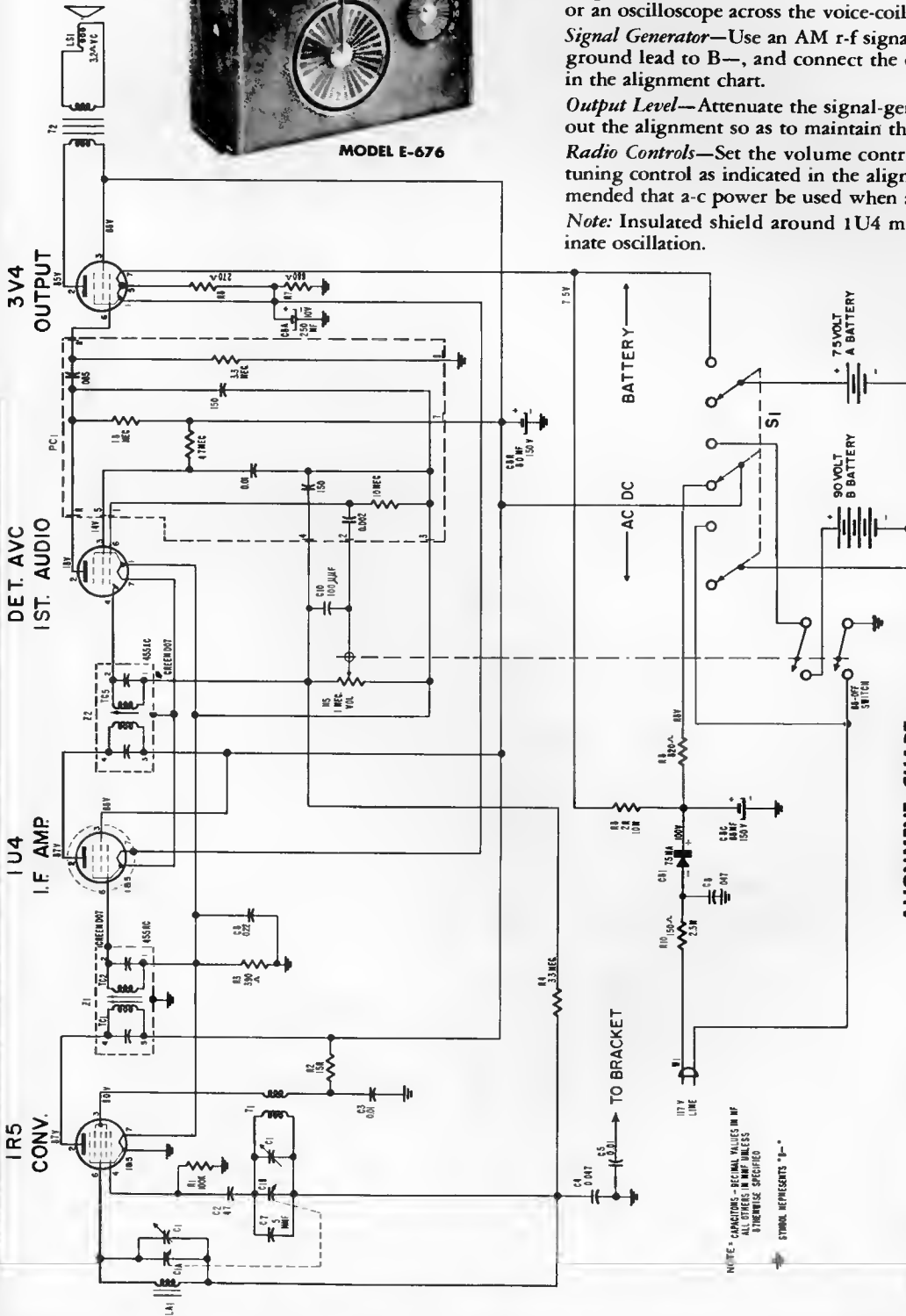

ALIGNMENT CHART

STEP	SIGNAL GENERATOR		RADIO		ADJUST
	CONNECTION TO RADIO	DIAL SETTING	DIAL SETTING	SPECIAL INSTRUCTIONS	
1	Connect signal generator through a .1 mfd condenser to pin 6 (converter grid) of IR5.	455 kc.	Tuning gang fully open.	Adjust for maximum output in order given.	TC3—2nd I-F sec. TC2—1st I-F sec. (top Z1) TC1—1st I-F pri. (Bot. Z1)
2	Use radiating loop (See note one below).	1620 kc.	1620 kc. (See note 2 below.)	Adjust for maximum.	C1B—osc. trimmer
3	Same as step 2.	1400 kc.	1400 kc. (Tune for signal.)	Adjust for maximum.	C1A—ant. trimmer

NOTE 1: Use a 6 to 8-in., 6 inch diameter loop made up of insulated wire. Connect to generator terminals, and place about one foot from radio loop.  
NOTE 2: The tuning condenser can be set to the proper frequency for the oscillator adjustment as follows: Fully open the tuning gang and insert a .006 non-metallic shim between the heel of the rotor and the top of the stator plates. Close the gang sufficiently to hold the shim in place, and then remove the shim without disturbing the gang setting.

# PHILCO

## MODELS E-740, E-742, E-810 E-812, E-814 and E-816

Model E-1370 phono-radio is similar to these radio models.

(Alignment and other service material is on the next page adjacent at right.)

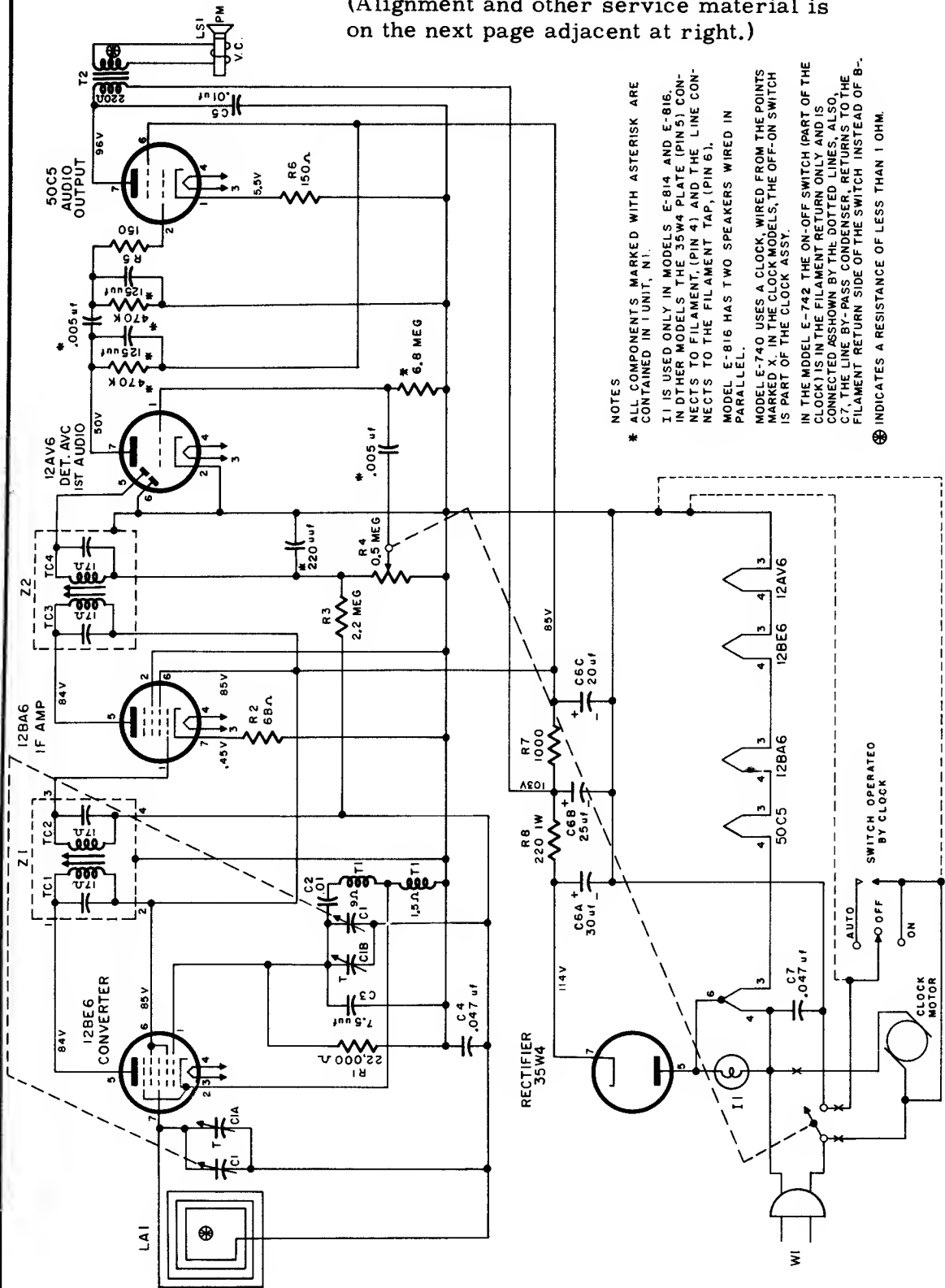

NOTES  
 \* ALL COMPONENTS MARKED WITH ASTERISK ARE CONTAINED IN 1 UNIT, N1.  
 I I IS USED ONLY IN MODELS E-814 AND E-816. IN OTHER MODELS THE 35W4 PLATE (PIN 5) CONNECTS TO FILAMENT (PIN 4) AND THE LINE CONNECTS TO THE FILAMENT TAP (PIN 6).  
 MODEL E-816 HAS TWO SPEAKERS WIRED IN PARALLEL.  
 MODEL E-740 USES A CLOCK WIRED FROM THE POINTS MARKED X IN THE CLOCK MODELS, THE OFF-ON SWITCH IS PART OF THE CLOCK ASSY.  
 IN THE MODEL E-742 THE ON-OFF SWITCH (PART OF THE CLOCK) IS IN THE FILAMENT RETURN ONLY AND IS CONNECTED AS SHOWN BY THE DOTTED LINES. ALSO, C7, THE LINE BY-PASS CONDENSER, RETURNS TO THE FILAMENT RETURN SIDE OF THE SWITCH INSTEAD OF B-.  
 ⊕ INDICATES A RESISTANCE OF LESS THAN 1 OHM.

Schematic Diagram — Models E-740, E-742, E-810, E-812, E-814 and E-816

(Alignment and other service material is on the next page adjacent at right.)



PHILCO Models E-740, E-742, E-810, E-812, E-814, and E-816  
(Continued from the preceding page at left)

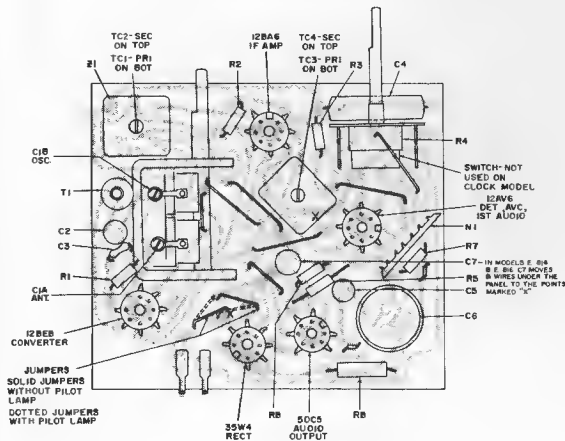

Printed Panel Component Layout—Models E-740, E-808, E-810, E-812, E-814 and E-816

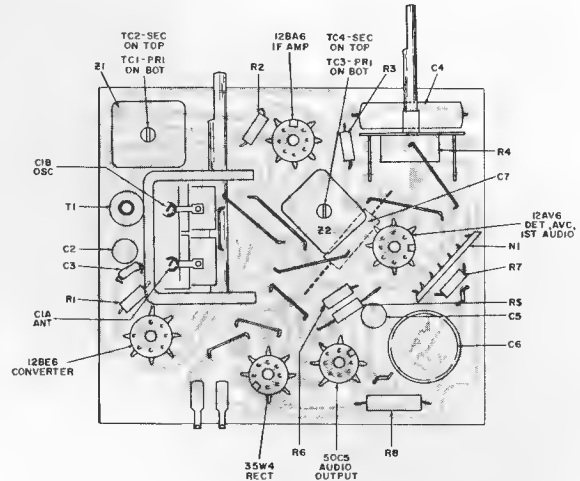

Printed Panel Component Layout—Model E-742

Frequency Range—540 KC to 1620 KC.

Intermediate Frequency—455 KC.

Audio Output—9 watt.

Power Consumption—30 watts.

Operating Voltage—E-740 and E-742, 105 to 120 volts, 60 cycles; E-808, E-810, E-812, E-814, and E-816, 105 to 120 volts, AC-DC.

Aerial—High Impedance loop mounted on inside of back.

**ALIGNMENT PROCEDURE**

**Radio Controls**—Set volume control to maximum. Set tuning control as indicated in chart.

**Output Meter**—Connect across voice coil terminals.

**Signal Generator**—Connect generator and set frequency as indicated in chart. Use modulated output, 30%.

**Output Level**—During alignment, adjust signal-generator output to hold output-meter reading below .5 volts.

**SPEAKER PHASING (Model E-816 Only)**

When replacing or reconnecting the two, paralleled speakers, it is possible that an out-of-phase condition may exist. This is readily apparent by weak output and serious distortion. To correct, interchange the leads to one of the speakers.

**CHASSIS REMOVAL**

- (1) Remove Back: In models E-808 and E-810 there are two screws holding the back to the cabinet. In models E-710, E-742, E-812, E-814 and E-816, spring the cabinet top to allow the back top to come back and out. Then lift (or slide upwards) the back to free back from bottom slots. Disengage interlock.
- (2) Remove the drive screw which holds the volume control frame to a boss on inside of cabinet front.
- (3) It may be desirable or necessary to unsolder the two speaker leads to obtain full chassis freedom.

**ALIGNMENT CHART**

STEP	SIGNAL GENERATOR		RADIO		ADJUST
	CONNECTION TO RADIO	DIAL SETTING	DIAL SETTING	SPECIAL INSTRUCTIONS	
1.	Ground lead to B-; output lead through a .1 mf condenser to grid (pin 7) of 12BE6.	455 kc.	Tuning gang fully open.	Adjust tuning cores, in order given, for max. output. TC1 and TC3 are located on top of transformers.	TC4—2nd i-f sec. TC3—2nd i-f pri. TC2—1st i-f sec. TC1—1st i-f pri.
2.	Radiating loop (See note below).	1620 kc.	1620 kc.*	Adjust for maximum output.	C1-B—osc.
3.	Same as Step 2.	1500 kc.	1500 kc.	Adjust for maximum output.	C1-A—aerial.

Note: Make up a 6-B turn, 6 inch diameter loop from insulated wire, connect to signal generator leads, and place near radio loop.

\* For proper adjustment of the oscillator trimmer, fully open the tuning gang and insert a .006 inch non-metallic shim between the heel of the rotor and the top of the stator plates. Close the tuning gang sufficiently to hold the shim in place, and then remove the shim without disturbing the gang setting.

# PHILCO

## E-748 and E-818

(Continued on the next page adjacent at right.)

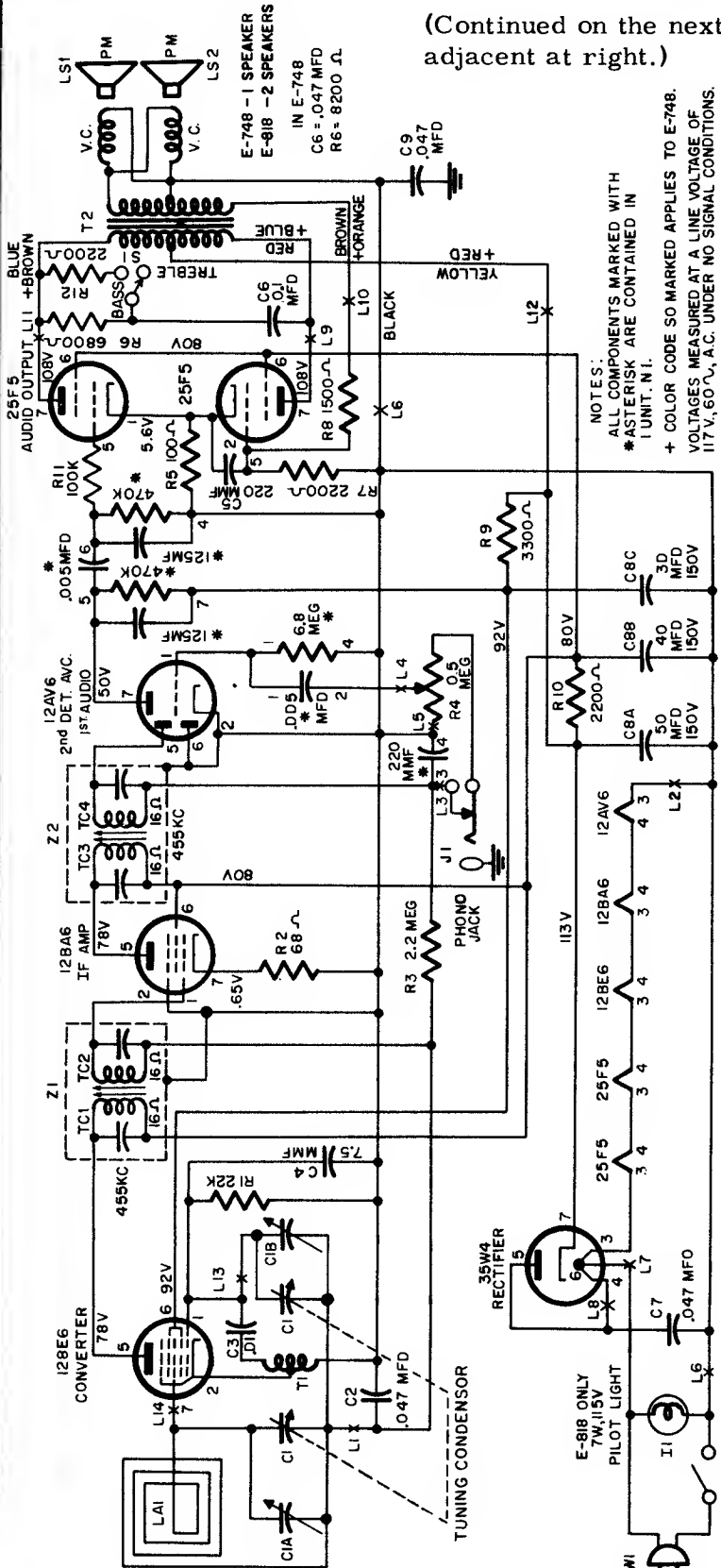

E-748 - 1 SPEAKER  
E-818 - 2 SPEAKERS  
IN E-748  
C6 = .047 MFD  
R6 = 8200 Ω

NOTES:  
ALL COMPONENTS MARKED WITH \* ASTERISK ARE CONTAINED IN 1 UNIT, N.I.  
+ COLOR CODE SO MARKED APPLIES TO E-748.  
VOLTAGES MEASURED AT A LINE VOLTAGE OF 117 V., 60 Hz., A.C. UNDER NO SIGNAL CONDITIONS.  
S1, TONE SWITCH, AND R12 ARE USED IN THE MODEL E-818 ONLY.  
CLOCK CIRCUIT, LIGHT AND SWITCH ARE USED IN MODEL E-748 ONLY.

IN MODEL E-748, THE RADIO ON-OFF SWITCH IS PART OF THE CLOCK ASSY. AND WIRES BETWEEN L2-L6 IN THE FILAMENT RETURN. THIS PROVIDES THE SLOW SHUT-OFF "LULLAWAY" FEATURE.

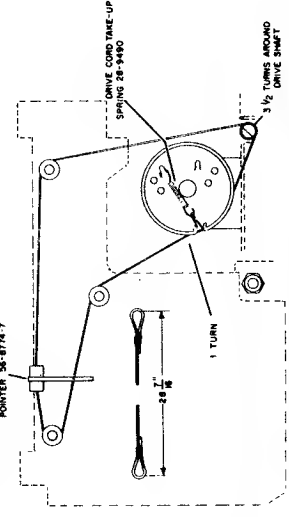

Dial Cord Stringing - Model E-748

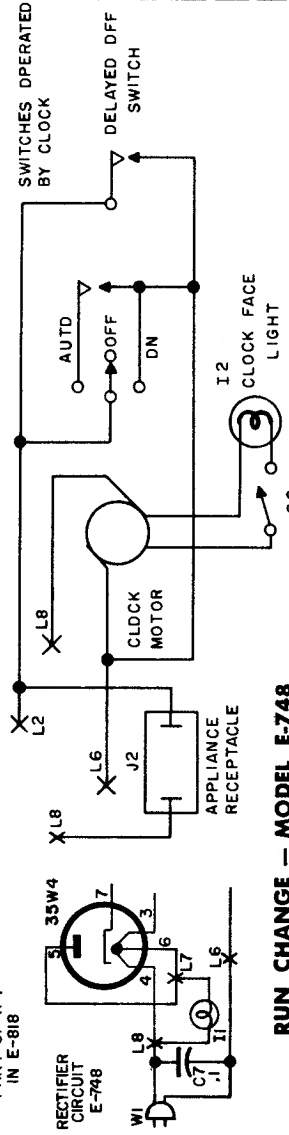

SWITCHES OPERATED BY CLOCK  
AUTD  
DELAYED OFF SWITCH  
CLOCK FACE LIGHT  
I2  
#43, 2.5V., 500MA  
E-818, PILOT LAMP WIRES ACROSS L6-L7.  
E-748, PILOT LAMP WIRES ACROSS L7-L8; ALSO JUMPER MOVES, CONNECTING RECTIFIER PLATE (PIN 5) TO L7, FILAMENT TAP (PIN 6).  
T2 RESISTANCE E-748 E-818  
TOTAL PRI. 390 Ω 395 Ω  
FEEDBACK 13.8 Ω 12.5 Ω  
SEC. 0.53 Ω 0.125 Ω

### RUN CHANGE - MODEL E-748

RUN 2 - R8, the feedback resistor was changed in value to 2200 ohms, part number 66-2228340. This change was made to improve the audio feedback characteristics. When replacing, use the new value, 2200 ohms.

(Alignment and other service material is printed on the next page adjacent at right.)

PHILCO Models E-748 and E-818 (Continued from preceding page)

**CHASSIS REMOVAL — MODEL E-748**

1. Remove knobs. Remove (2) 1/4-in. hex head drive screws from cabinet back. Disengage A.C. interlock. Remove back by freeing clock time set shaft and then swivel back around left side.
2. Remove (2) 1/4-in. hex head drive screws from top corners of dial back plate.
3. Remove (2) 1/4-in. hex head drive screws from cabinet bottom.
4. Remove (2) 1/4-in. hex head drive screws from rear bottom of chassis frame.

**CHASSIS REMOVAL — MODEL E-818**

1. Remove knobs. Remove (6) Phillips head wood screws from back. Disengage A.C. interlock. Remove back by swiveling toward left.
2. Remove (2) 1/4-in. hex head screws and washers holding A.C. interlock bracket.
3. Unsolder the two leads, from receiver panel, from the right hand speaker.
4. Remove (4) 1/4-in. hex head drive screws that mount set to cabinet front from the chassis bracket.

**Tie Lug No. E-748 Connection**

- L1 ..... A-G-C to Ant. and Gang
- L2 ..... Filament side of A-C Switch
- L3 ..... Detector Output to J1
- L4 ..... Arm of Volume Control
- L5 ..... Volume Control Return to B—
- L6 ..... A-C line, line side of A-C Switch, and Black lead from T2
- L7 ..... One side of Pilot Lamp
- L8 ..... A-C line and one side of Pilot Lamp
- L9 ..... Blue lead to T2, Output Transformer
- L10 ..... Orange lead to T2
- L11 ..... Brown lead to T2
- L12 ..... Red lead to T2
- L13 ..... Oscillator section of Gang
- L14 ..... Ant. and Ant. section of Gang

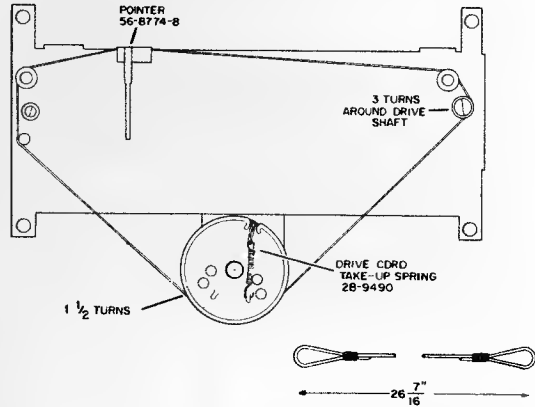

*Dial Cord Stringing — Model E-818*

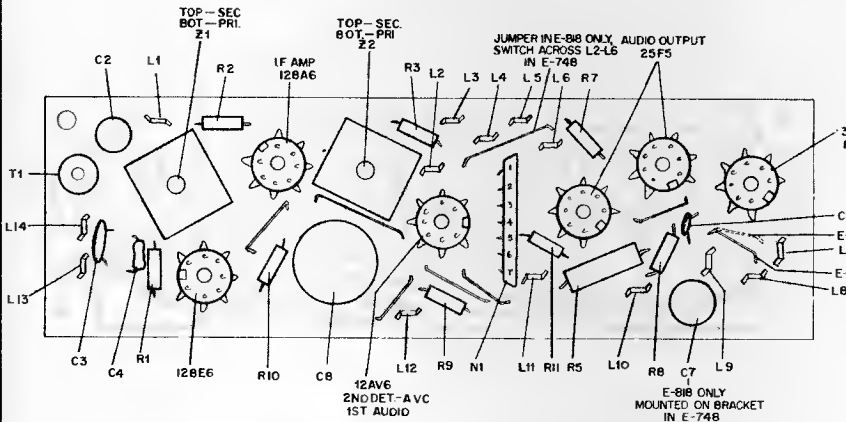

*Composite Base View — Models E-748 and E-818*

**E-818 Connection**

- A-G-C to Ant. and Gang
- Not used
- Detector Output to J1
- Arm of Volume Control
- Volume Control Return to B
- Set side of A-C Switch, one side of Pilot Lamp, and Black lead from T2
- A-C line
- Not used
- Red lead to T2, Output Transformer
- Brown lead to T2
- Blue lead to T2
- Yellow lead to T2
- Oscillator section of Gang
- Ant. and Ant. section of Gang

**ALIGNMENT PROCEDURE**

**Radio Controls** — Set volume control to maximum. Set tuning control as indicated in chart.

**Output Meter** — Connect across voice coil terminals.

**Signal Generator** — Connect generator and set frequency as indicated in chart. Use modulated output, 30%.

**Output Level** — During alignment, adjust signal-generator output to hold output-meter reading below .5 volts.

**ALIGNMENT CHART**

STEP	SIGNAL GENERATOR		RADIO		ADJUST
	CONNECTION TO RADIO	DIAL SETTING	DIAL SETTING	SPECIAL INSTRUCTIONS	
1	Ground lead to 8—; output lead through a .1 mf condenser to grid (pin 7) of 12B26.	455 kc.	Tuning gang fully open.	Adjust tuning cores, in order given, for maximum output. TC1 and TC3 are located on top of transformers.	TC4—2nd i-f sec. TC3—2nd i-f pri. TC2—1st i-f sec. TC1—1st i-f pri.
2	Radiating loop. (See note below).	1620 kc.	1620 kc. *	Adjust for maximum output.	C1-B—osc.
3	Same as Step 2.	1500 kc.	1500 kc.	Adjust for maximum output.	C1-A—aerial.

Note: Make up a 6-8 turn, 6 inch diameter loop from insulated wire, connect to signal-generator leads, and place near radio loop.

\* For proper adjustment of the oscillator trimmer, fully open the tuning gang and insert a .006 inch non-metallic shim between the heel of the rotor and the top of the stator plates. Close the tuning gang sufficiently to hold the shim in place, and then remove the shim without disturbing the gang setting.

# PHILCO MODEL E-976

(For alignment see the next page adjacent at right)

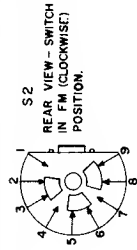
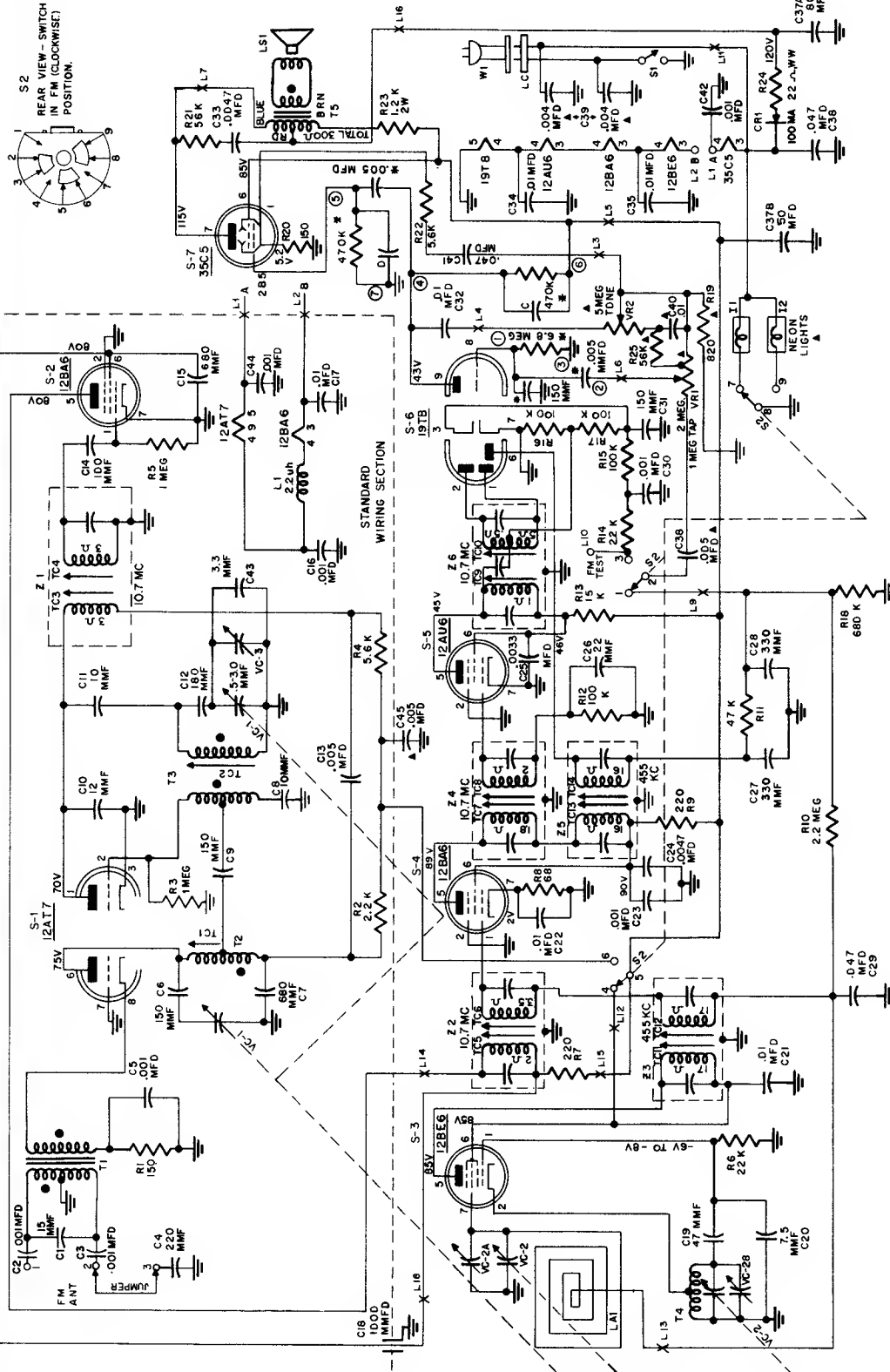

**Audio Output** — 1 watt  
 Variable bass boost or treble cut tone control  
 Operating Voltage — 105 - 125 volts, a.c./d.c.  
 Power Consumption — 40 watts  
 Antennas — AM — Built in high impedance, pancake loop  
 FM — Line cord with provision for connecting external antenna.  
 Intermediate Frequency — AM 455 KC  
 FM 10.7 MC

### SPECIFICATIONS

**Cabinet** — Wood table model — Mahogany, Blonde or Fruitwood. Dual slide-rule dial with neon band indicators.  
**Circuit** — Seven-tube superheterodyne plus selenium rectifier.  
**Frequency Ranges** — Tuning drive ratio 12:1  
 Broadcast — 540-1620 KC  
 FM — 88-108 MC

Components marked with an \* are part of N1, the Audio Circuit Coupler. Condensers "C" plus "D" equal 250 mmf in couplet.  
 Components marked ▲ are part of chassis wiring.

(Continued on the next page)

PHILCO Model E-976 (Continued from the preceding page at left)

**AM ALIGNMENT PROCEDURE**

**OUTPUT INDICATOR** — Connect either an a-c voltmeter or an oscilloscope across the voice coil terminals.

**SIGNAL GENERATOR** — Use an AM r-f signal generator with modulated output.

1. Connect generator, through a .05 mfd condenser, to grid, pin 7, of the AM converter, S-3. Connect ground lead to chassis.
2. Set generator to 455 kc, tuning gang fully closed and adjust, in order given, TC14, TC13, TC12 and TC11 for maximum output. Repeat until no further gain is indicated.
3. Connect generator to radiating loop. Set generator to 1600 kc. Set receiver to 1600 kc as indicated by pointer. Adjust VC-2B for maximum.
4. Set generator to 1400 kc. Tune receiver to signal and adjust VC-2A for maximum.

**FM ALIGNMENT PROCEDURE**

1. Calibrate the scope for 2 volts P/P.
2. Connect the scope, through a 100,000 ohm isolating resistor, to junction of R12 and C26. Scope ground lead to chassis.
3. Connect the signal generator to bottom of T1 secondary (junction of T1 with R1 and C5). Generator ground lead to chassis.
4. Inject marker signal, 10.7 mc (unmodulated).
5. Inject sweep signal, 10.7 mc, approximately 150 kc total deviation (do not over sweep).
6. Adjust cores TC8, TC7, TC6, TC5, TC4 and TC3

for maximum amplitude, symmetrical curve with the 10.7 mc marker at top of curve. Adjust input signal to maintain output, as shown on scope, below 2 volts peak during alignment. Repeat step 6 until no further gain is obtained.

7. Calibrate the scope for 5 volts P/P.
8. Change the scope connections to L10 (FM audio output to function switch).
9. Remove sweep signal. Inject 10.7 mc, 30% AM modulated signal. Adjust TC10 for minimum indication between peaks. See note below.
10. Inject 10.7 mc sweep signal and adjust TC9 for maximum symmetrical output.
11. Touch up cores as in Step 6 plus TC9 for a symmetrical, maximum amplitude, discriminator curve. To check alignment, discriminator curve should not shift in frequency with an increase in signal input (below overload). If a shift does occur, the I-F is not properly aligned, particularly the first stage, TC3 and TC4.
12. Inject 108.5 mc 30% AM modulated signal, through an antenna matching network to the receiver antenna terminals.
13. Open tuning condenser. Insert a 6 mil, non-metallic, shim between stator and rotor of the FM gang and close gang against shim. Adjust VC3 for minimum indication between peaks.
14. With tuning condenser fully closed, inject 87.75 mc, 30% AM modulated, signal and adjust TC2 for minimum indication between peaks. See note below.
15. Inject 91 mc, sweep signal and with tuning gang tuned to 91 mc, adjust TC 1 for maximum output.

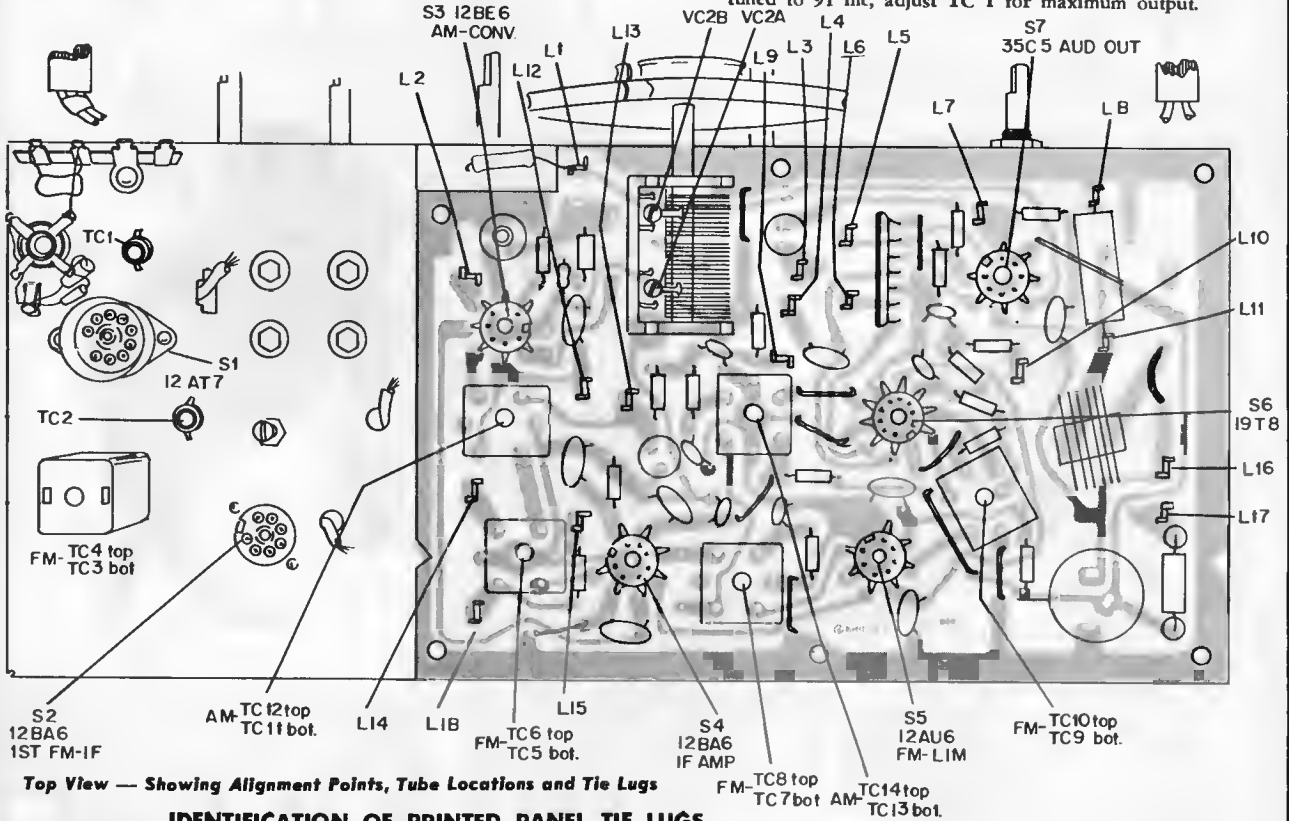

Top View — Showing Alignment Points, Tube Locations and Tie Lugs

**IDENTIFICATION OF PRINTED PANEL TIE LUGS**

- |   |  |  |
|---|--|--|
| <p>L1 Filament lead from pin 4 of S-7 (35C5) to pin 5 of S-1 (12AT7)</p> <p>L2 Filament lead from pin 3 of S-2 (12BA6) to pin 3 of S-3 (12BE6)</p> <p>L3 Green lead to junction of R19, C40, bottom of VR1 and arm of VR2 from C41</p> <p>L4 Yellow lead from high side of VR2 to C32</p> <p>L5 Red lead (B+) from lug 5 of S-2 to screen of S-7 and terminal 6 of N1</p> <p>L6 Yellow lead from arm of VR1 to terminal 2 of N1</p> | <p>L7 Blue lead from audio output, T-5, to plate, pin 7 of S-7</p> <p>L8 Bare wire from panel ground to chassis ground</p> <p>L9 Yellow lead, AM audio to lug 1 of S2 from junction of R11, C28, R10 and R18</p> <p>L10 Orange lead, FM audio to lug 3 of S2</p> <p>L11 Brown lead to AC interlock and two white leads to pilot lamps</p> <p>L12 Red lead (B+) from lug 4 of S2 to AM converter screen, pin 6, and Z3.</p> | <p>L13 Loop antenna return to A.V.C.</p> <p>L14 Blue lead from plate, pin 5 of S2, to 2nd FM I-F transformer, Z2</p> <p>L15 Red lead (B+) from lug 5 of S2 to R7</p> <p>L16 Red lead from junction of R24 and C37A to audio output, T5</p> <p>L17 Brown lead from audio output, T5, to R23</p> <p>L18 Orange lead (B+) to C18 feed-through</p> |
|---|--|--|

### PHILCO PHONOGRAPH

#### MODEL E-1360

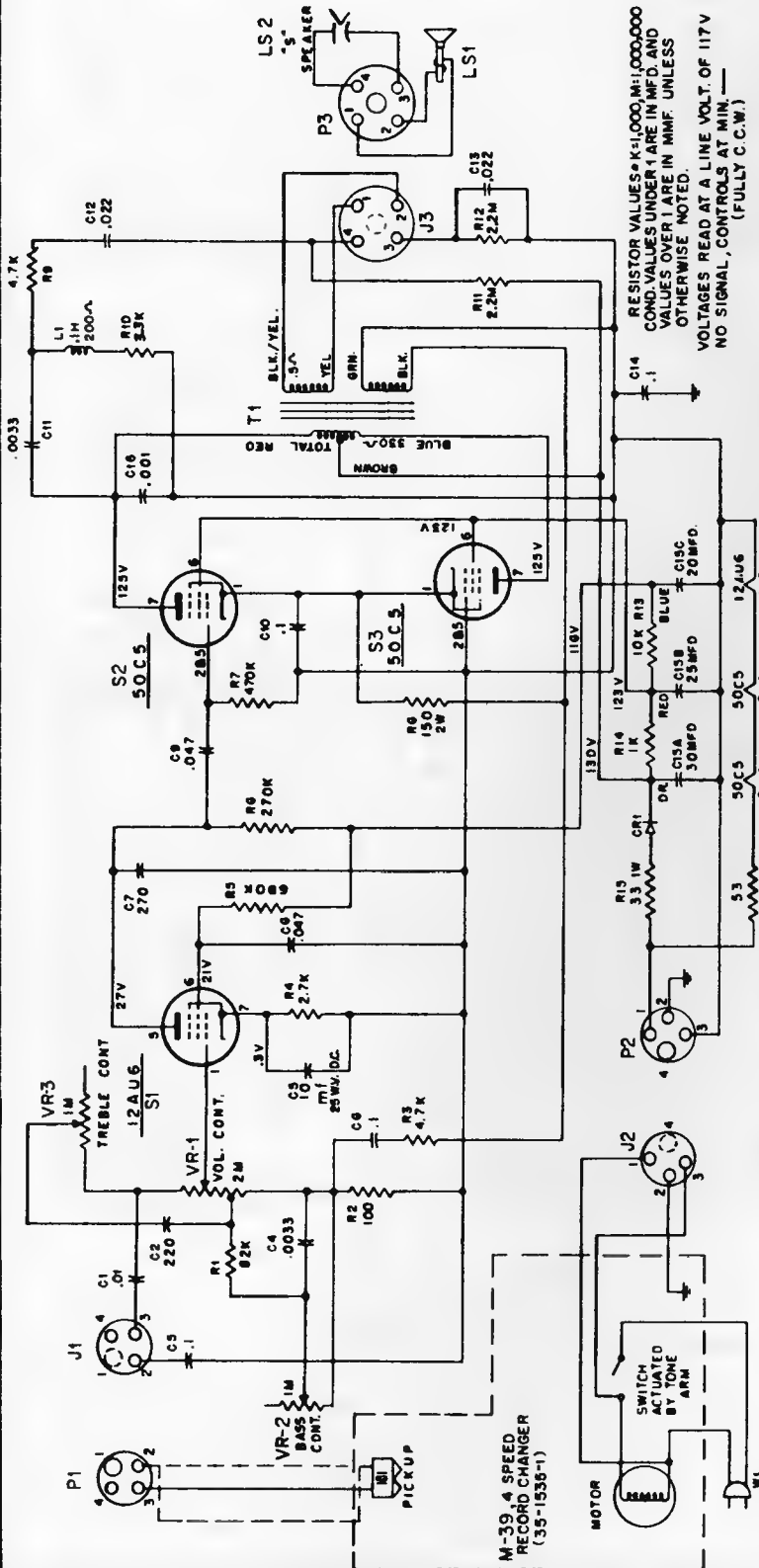

### PHILCO PHONOGRAPH

#### Models E-1351, E-1353, E-1355

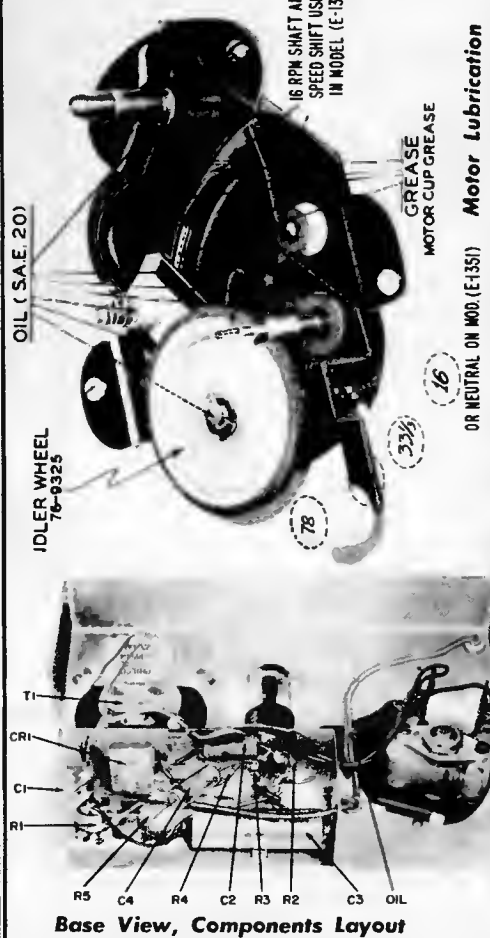
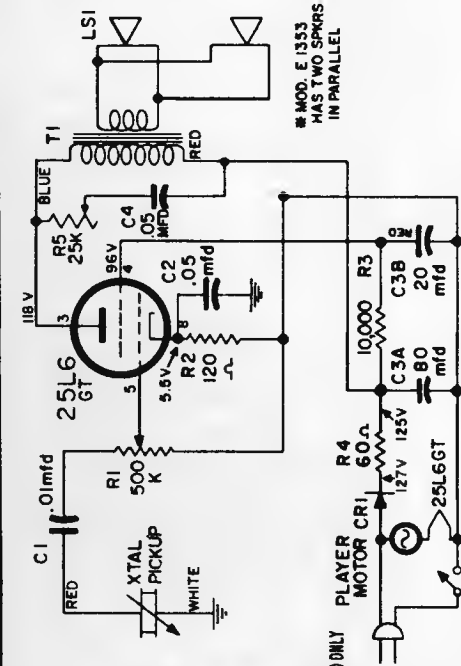

# PHILCO HI-FIDELITY PHONOGRAPHS

## MODELS E-1363, E-1763 and E-1765

MODEL NO.	I1	C4	S2	S3
E1363	OMIT	.0033 μf	6K6 6T	
E1763	USE	.0068 μf	6V6 6T	
E1765	USE	.0068 μf	6V6 6T	

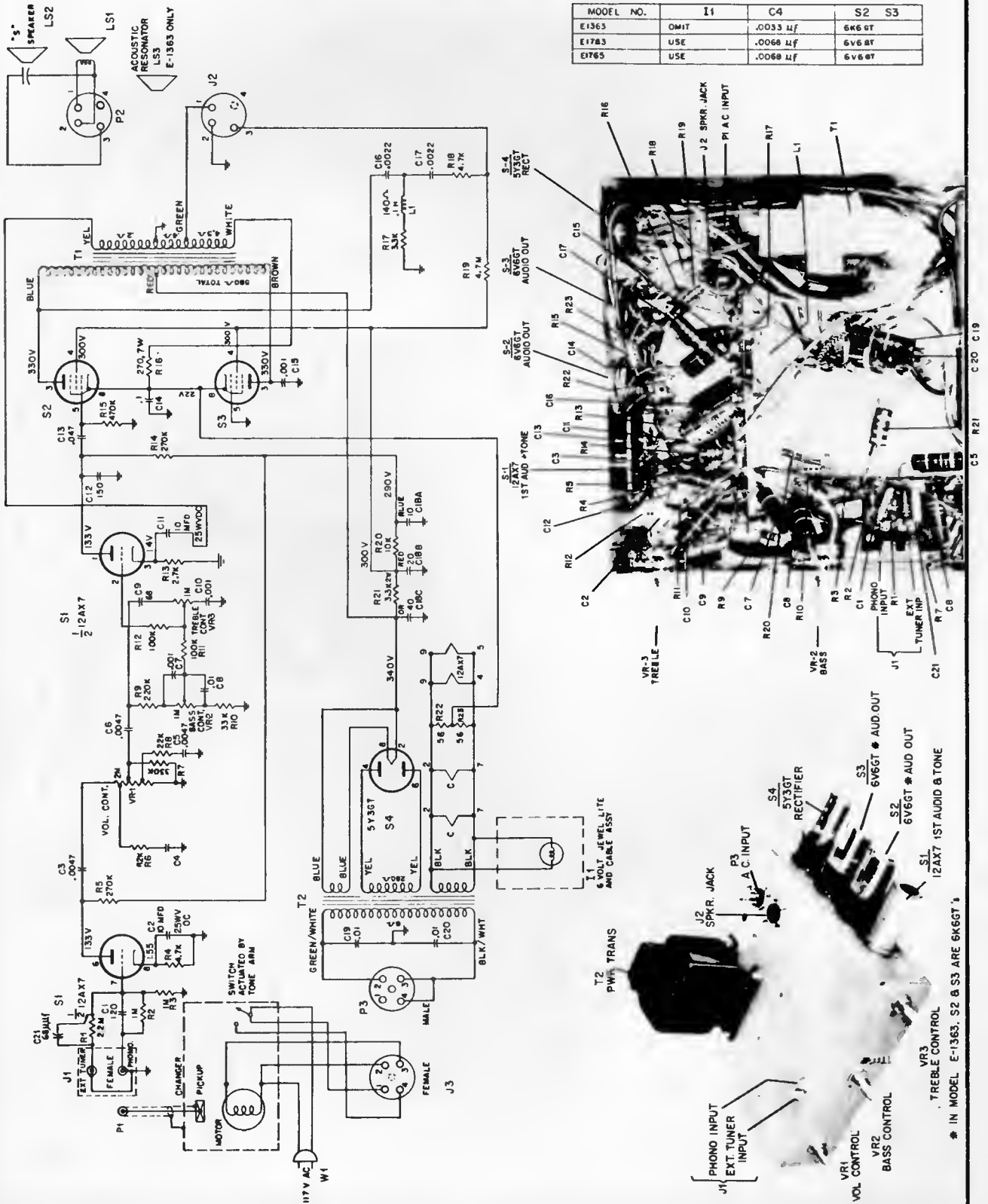

\* IN MODEL E-1363, S2 & S3 ARE 6K6GT

# PHILCO PORTABLE RADIO Transistor Model T-7

(For alignment and other service data see the next page adjacent at right)

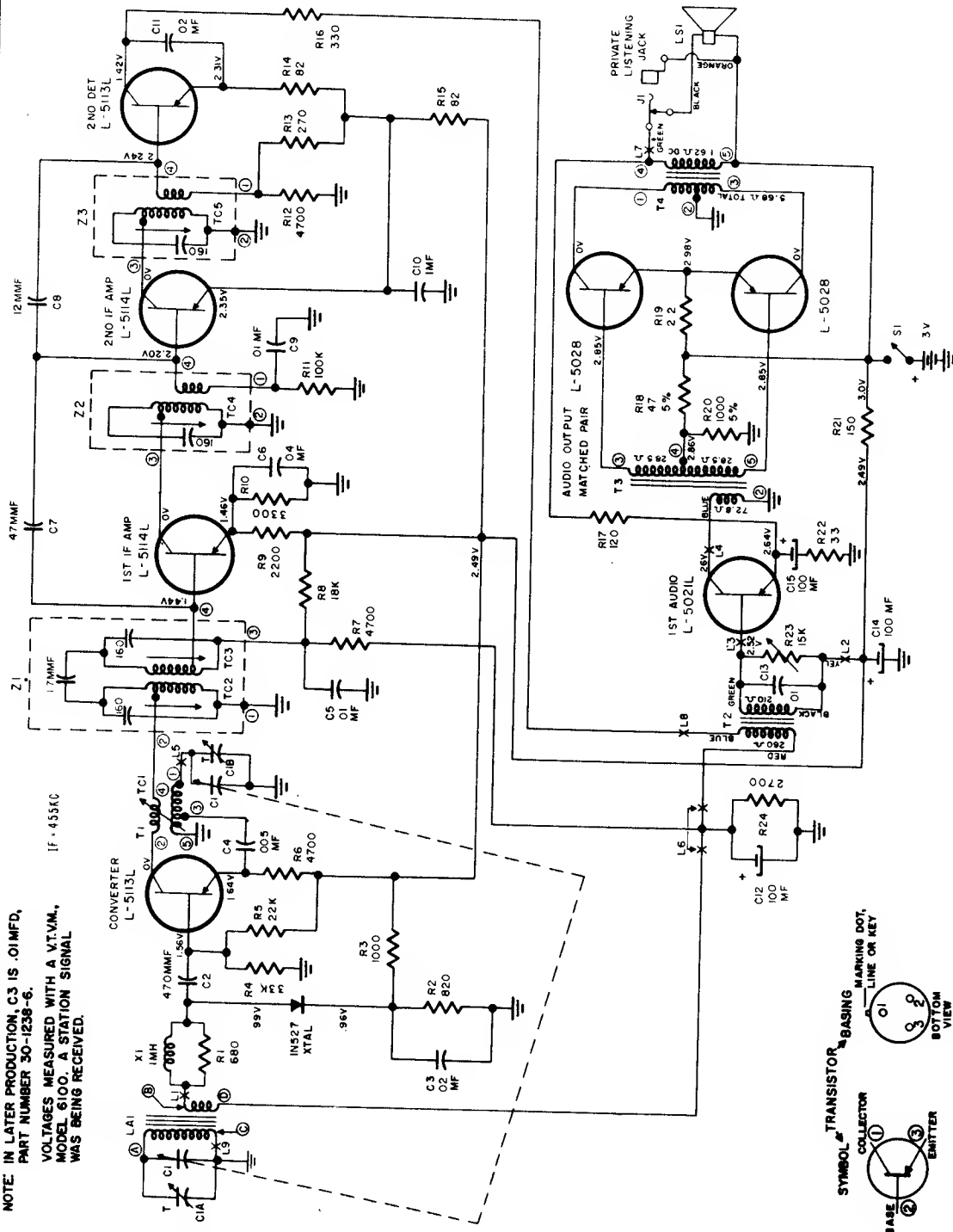

NOTE: IN LATER PRODUCTION, C3 IS .01MFD, PART NUMBER 30-1238-6. VOLTAGES MEASURED WITH A VTVM, MODEL 6100, A STATION SIGNAL WAS BEING RECEIVED.

### SERVICE NOTES

When signal tracing, inject signal at transistor collector and limit input to keep signal across speaker below 0.8 volts.  
Normally, the transistors should be the last item suspected.

If C15 opens serious audio oscillation will result. Dress lead from top, center, frame lug of gang to end ground lug is important to reduce beat. See base layout for lead dress.

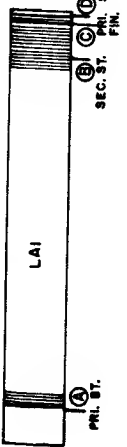
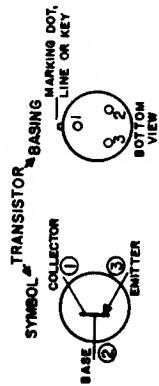



PHILCO Model T-7

(Continued from preceding page)

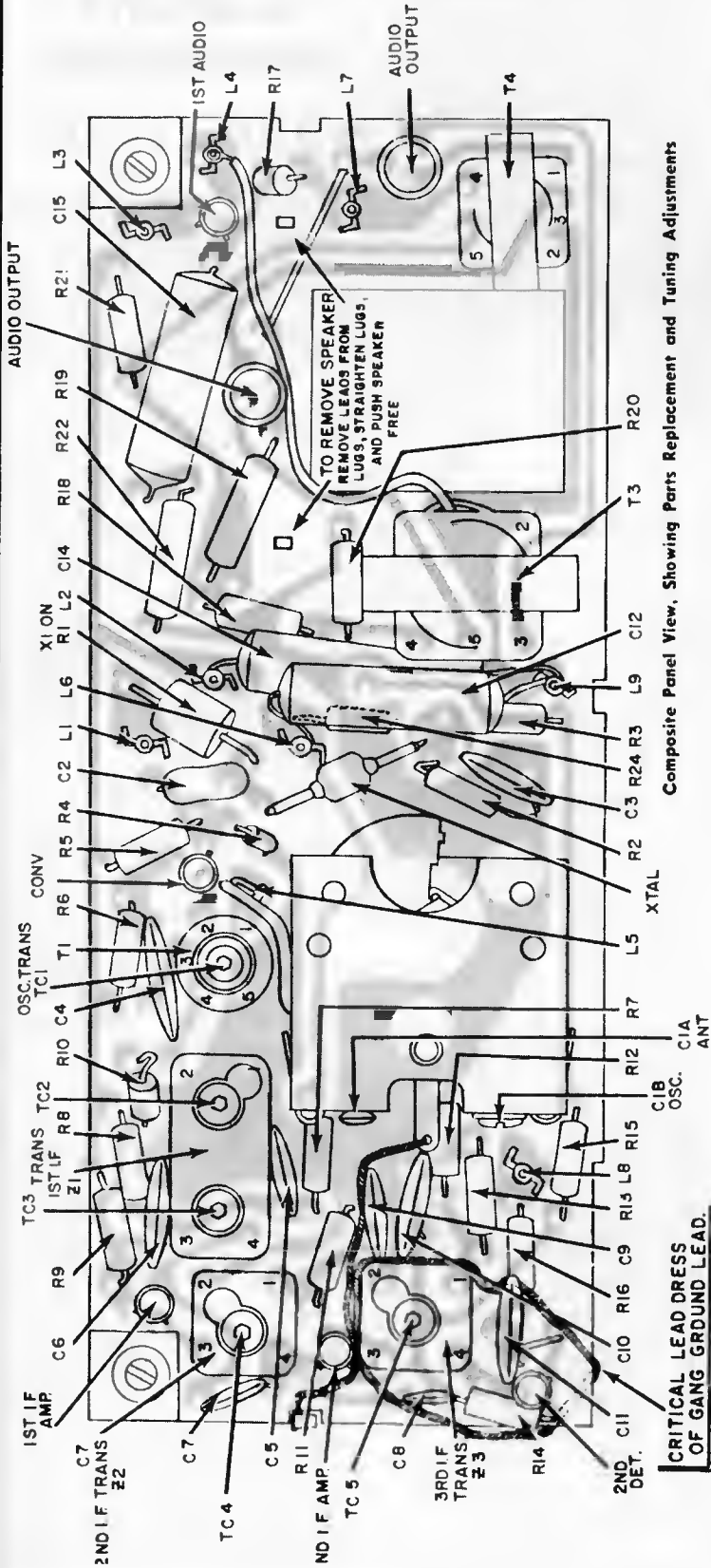

Composite Panel View, Showing Parts Replacement and Tuning Adjustments

ALIGNMENT CHART

STEP	SIGNAL GENERATOR		RADIO		ADJUST
	CONNECTION TO RADIO	DIAL SETTING	DIAL SETTING	SPECIAL INSTRUCTIONS	
1	Connect signal generator through a .1-uf. condenser to ant. section of gang.	455 kc.	Tuning gang fully open.	Adjust for maximum output in order given.	TC5-3rd i.f. pri. TC4-2nd i.f. pri. TC3-1st i.f. sec. TC2-1st i.f. pri. TC1-osc. core
2	Use radiating loop. (See NOTE 1 below.)	600 kc.	600 kc.	Adjust for maximum output. Rock tuning gong while making this adjustment.	
3	Same as step 2.	1620 kc.	1620 kc. (Turning gong fully open)	Adjust for maximum output.	C1B-osc. trimmer
4	Same as step 2.	1400 kc.	1400 kc.	Adjust for maximum output.	C1A-antenna trimmer
5	Repeat steps 2, 3, and 4 until no further improvement is obtained. Always stop on step 4.				

NOTE 1. Use a 6-to-8-turn, 6-inch-diameter loop made up of insulated wire. Connect to generator terminals, and place about one foot from radio loop.

ALIGNMENT PROCEDURE

**GENERAL**—Allow the test equipment to warm up for fifteen minutes before starting the alignment procedure.

**OUTPUT INDICATOR**—Connect the output indicator (a 1000-ohm-per-volt, a-c voltmeter, or an oscilloscope) across the voice-coil terminals.

**SIGNAL GENERATOR**—Use an AM r-f signal generator. Connect the ground lead to chassis, and connect the output lead as indicated in the alignment chart.

**OUTPUT LEVEL**—Attenuate the signal-generator output throughout the alignment so as to maintain the output level below .8 volt.

**RADIO CONTROLS**—Set the volume control to maximum. Set the tuning control as indicated in the alignment chart. During alignment of the radio, the batteries should be in the same position with respect to the chassis and the loop antenna as they normally are in the cabinet.

# PHILCO HI-FIDELITY PHONOGRAPH MODEL E-1766

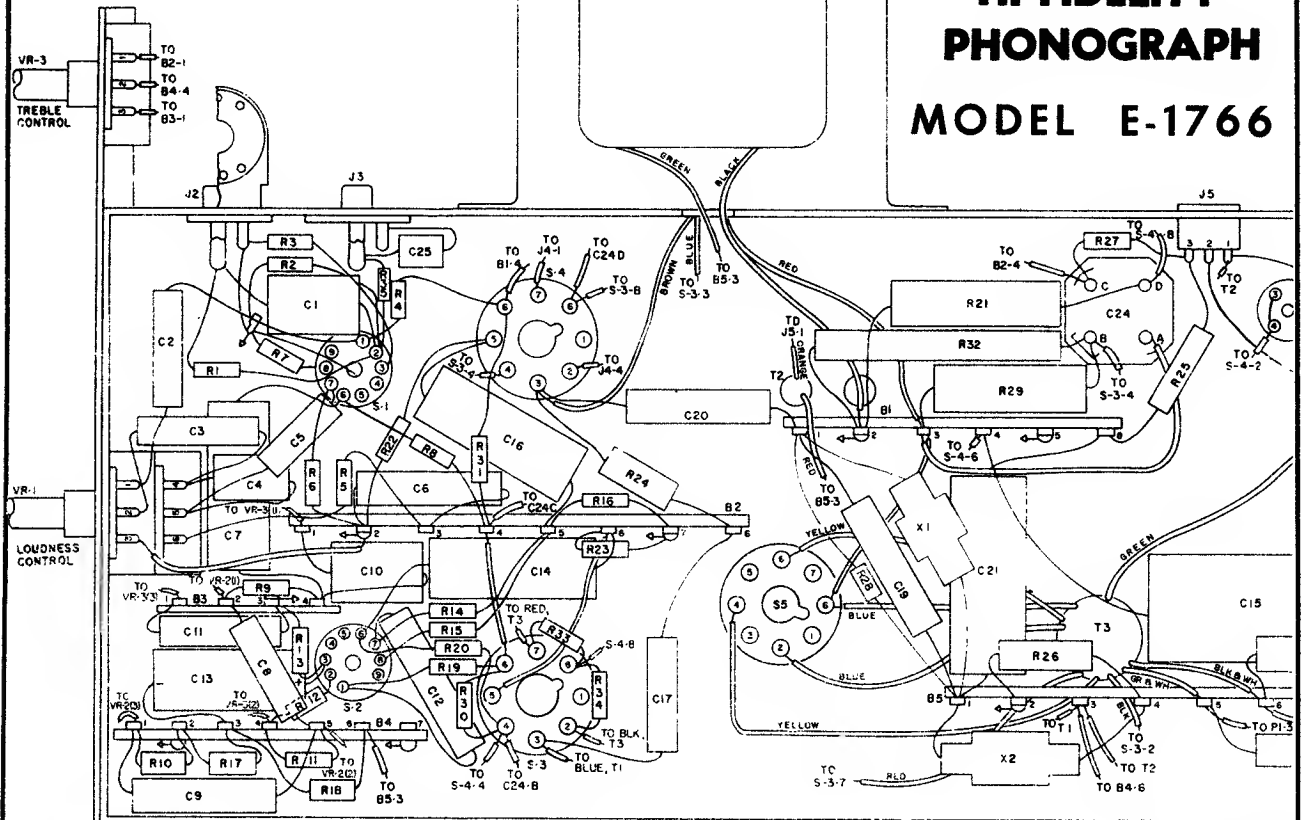

Base View - Model E-1766

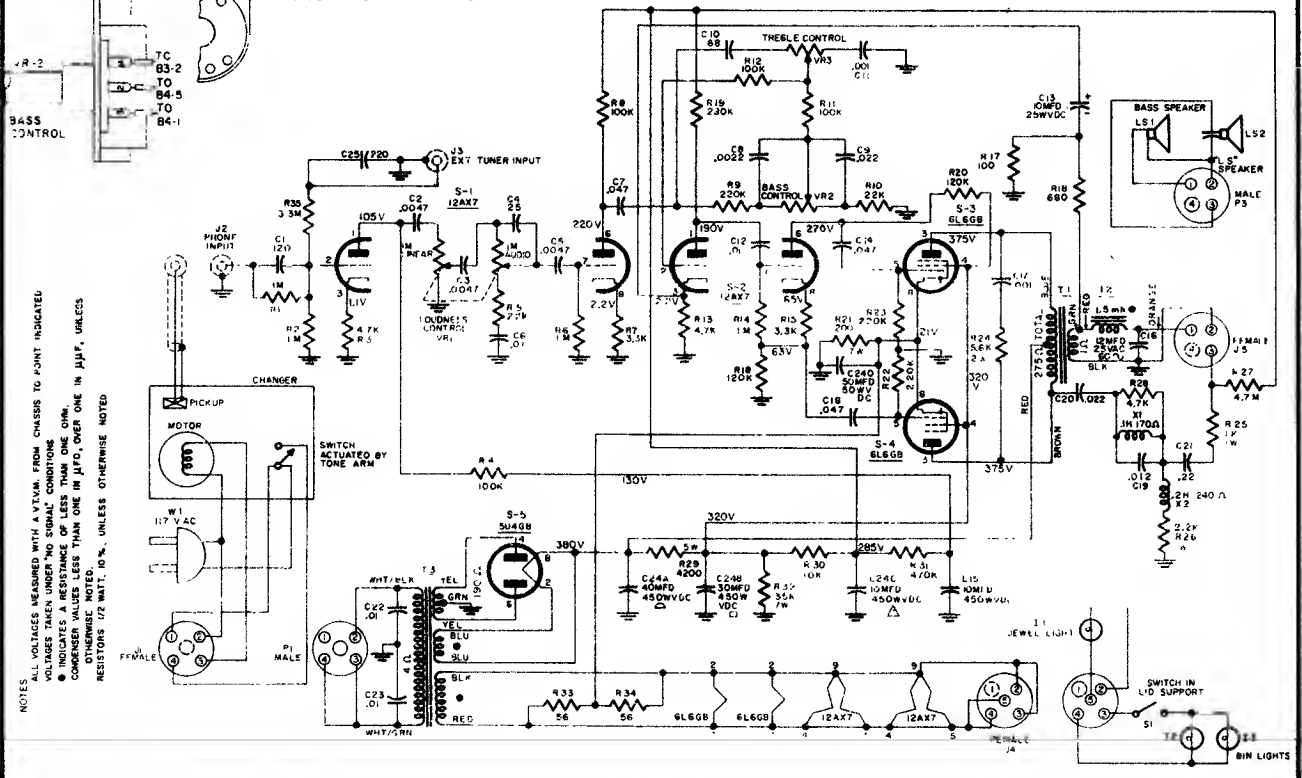

NOTES  
ALL VOLTAGES MEASURED WITH A VTVM FROM CHASSIS TO POINT INDICATED.  
VOLTAGES TAKEN UNDER "NO SIGNAL" CONDITIONS.  
RESISTOR VALUES LESS THAN ONE OHM.  
CAPACITOR VALUES LESS THAN ONE MICROFARAD, UNLESS OTHERWISE NOTED.  
RESISTORS 1/2 WATT, 5%, UNLESS OTHERWISE NOTED.

# RCA VICTOR 7-BX-6 SERIES, 7-BX-7 SERIES

Chassis Nos. RC-1161, RC-1161A

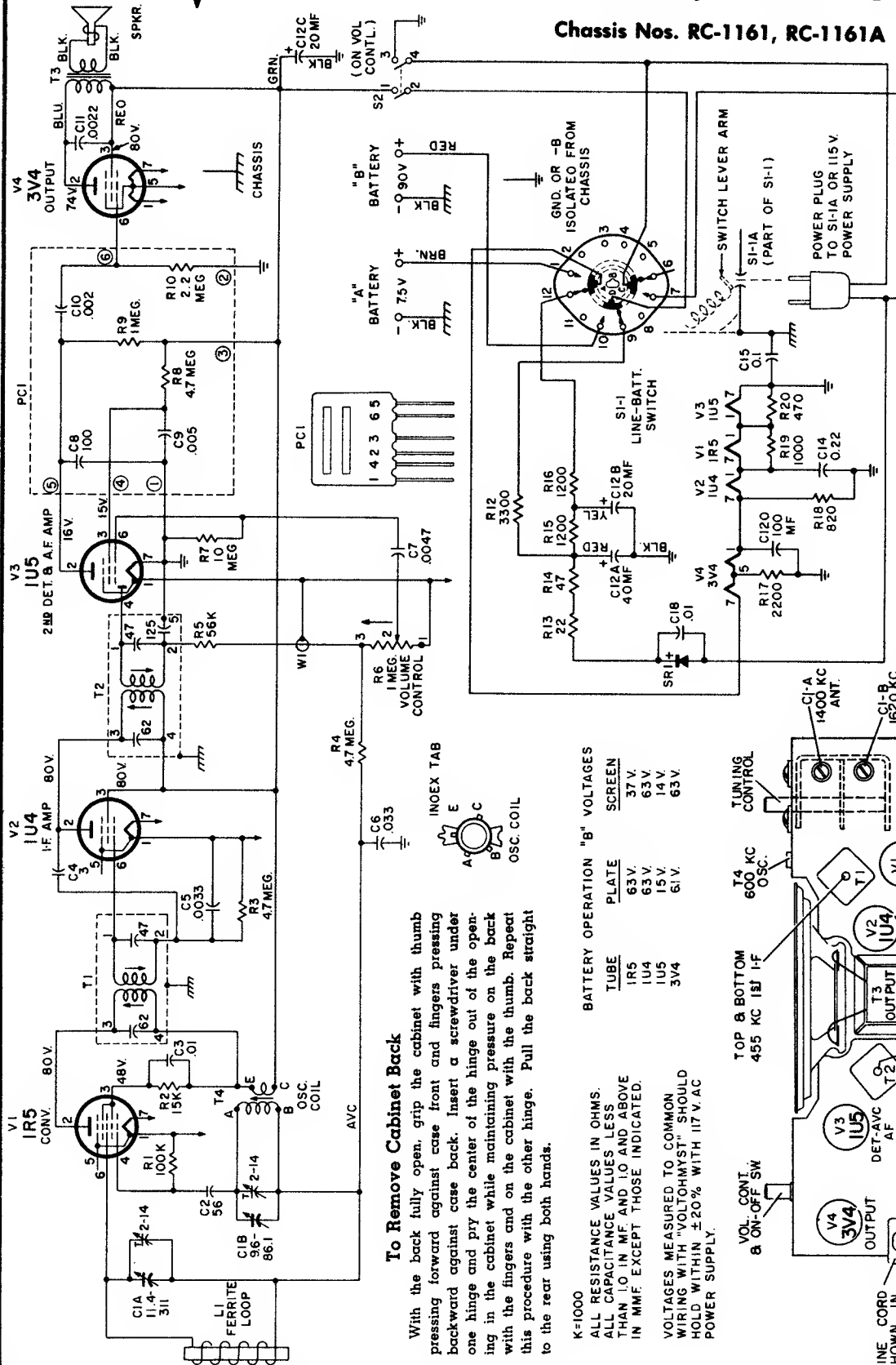

NOTE: WHEN POWER PLUG CONTACT IS INSERTED AGAINST SWITCH S1-1A LEVER ARM, SWITCH CONTACTS SHOWN (#) MOVE INTO POSITION 2 FOR BATTERY OPERATION. (INNER CONTACTS REMAIN STATIONARY).

NOTE: 3 POLE - 2 POSITION SWITCH S1 SHOWN FROM TERM. END WITH SWITCH SHAFT IN C/CLOCKWISE POSITION #1. (115V AC-DC OPERATION)

POSITION	FUNCTION
1	115V AC-DC OPERATION
2	BATTERY OPERATION

### To Remove Cabinet Back

With the back fully open, grip the cabinet with thumb pressing forward against case front and fingers pressing backward against case back. Insert a screwdriver under one hinge and pry the center of the hinge out of the opening in the cabinet while maintaining pressure on the back with the fingers and on the cabinet with the thumb. Repeat this procedure with the other hinge. Pull the back straight to the rear using both hands.

BATTERY OPERATION "B" VOLTAGES

TUBE	PLATE	SCREEN
IR5	63V.	37V.
IU4	63V.	14V.
IU5	15V.	63V.
3V4	61V.	

VOLTAGES MEASURED TO COMMON WIRING WITH "VOLTOHMYST" SHOULD HOLD WITHIN ±20% WITH 117 V. AC POWER SUPPLY.

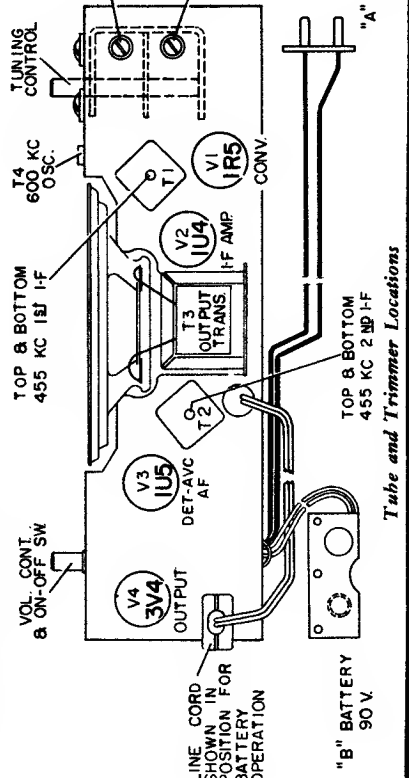

Tube and Trimmer Locations



# RCA VICTOR

AC-DC-Battery Portable Receiver

## MODEL 7-BX-9H

Chassis No. RC-1163

(Alignment and additional service information is on the next page adjacent at right.)

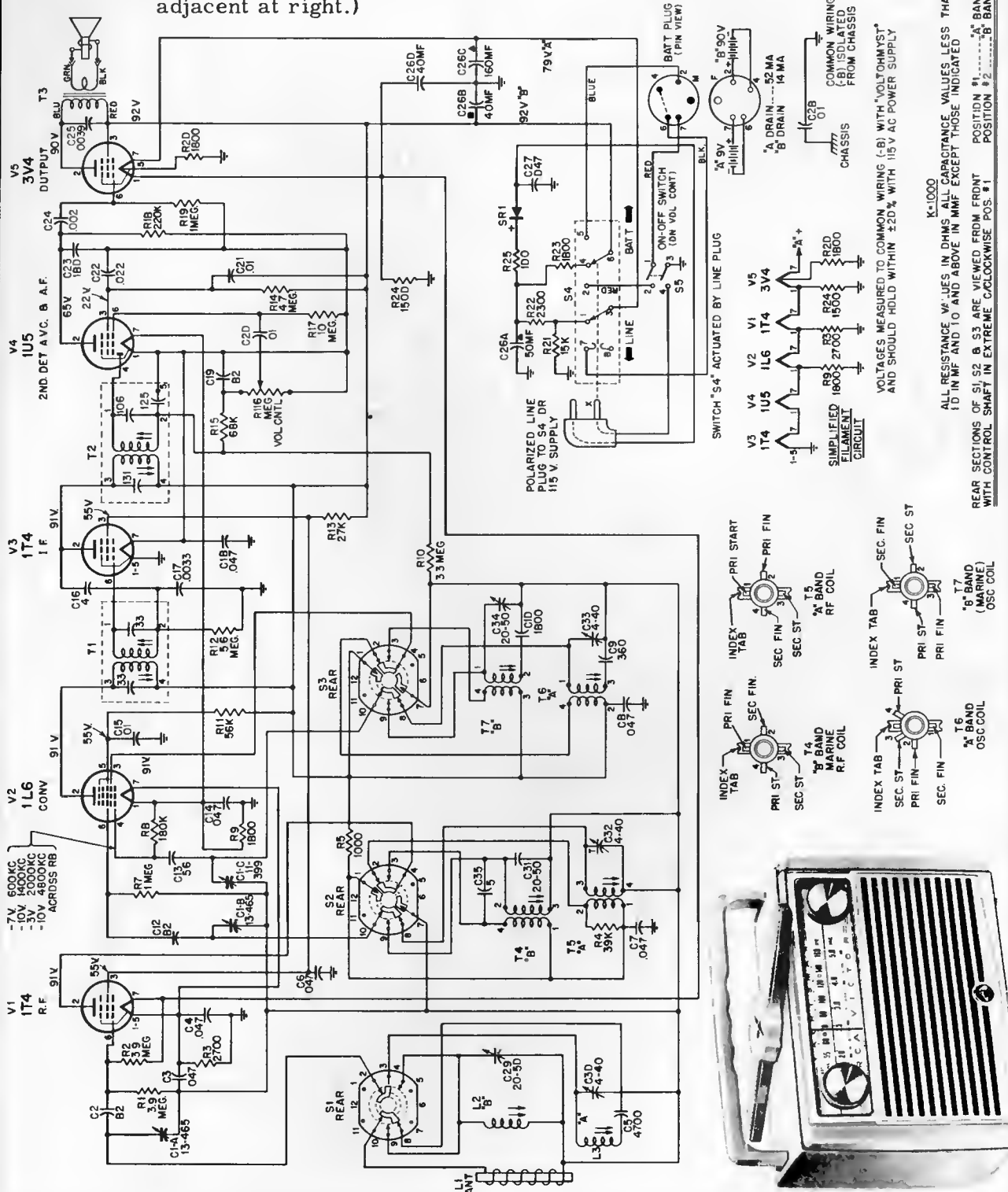

K=1000  
 ALL RESISTANCE VALUES IN OHMS. ALL CAPACITANCE VALUES LESS THAN 10 IN MF AND 10 AND ABOVE IN MMF EXCEPT THOSE INDICATED.  
 REAR SECTIONS OF S1, S2 & S3 ARE VIEWED FROM FRONT WITH CONTROL SHAFT IN EXTREME CLOCKWISE POS. #1 POSITION #1.....#A BAND #2.....#B BAND

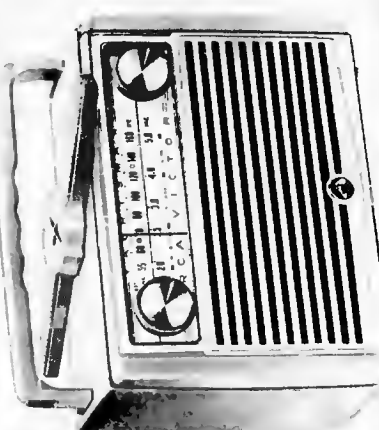
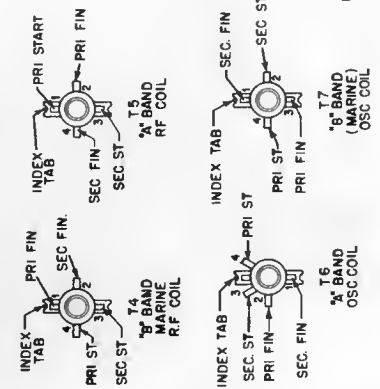

RCA Victor Model 7-BX-9H, Chassis RC-1163, Continued from previous page

Step	Connect High Side of Sig. Gen. to —	Sig. Gen. Output	Dial Pointer Setting	Adjust for Max. Output
1	Disconnect loop—remove chassis—remove bottom cover.			
2	Pin #6 of 1T4 I.F. Amplifier thru .005 mf.	455 kc	Quiet point near 1600 kc "A" Band	2nd I.F. Trans. T2 Top & Bottom
3	Pin #6 of 1R5 Converter thru .005 mf.			1st I.F. Trans. T1 Top & Bottom
4	Replace bottom cover and connect loop. Place loop in the same position in relation to chassis as when the receiver is fully assembled.			
5		1620 kc	gang fully open "A" Band	Osc. trimmer C33
6		1400 kc	1400 kc signal "A" Band	Ant. and R.F. trimmers C30 and C32
7		600 kc	600 kc signal "A" Band	T5 R.F. core and T6 Osc. core alternately while rocking gang
8	Short wire placed near antenna for radiated signal			
9		5200 kc	gang fully open "B" Band	Osc. trimmer C34
10		4800 kc	4800 kc signal "B" Band	Ant. and R.F. trimmers C29 and C31
11		2000 kc	2000 kc signal "B" Band	T4 R.F. core and T7 Osc. core alternately while rocking gang
12	Repeat Steps 5, 6 and 7			
13	Repeat Steps 9, 10 and 11			
13	Reassemble chassis and antenna in cabinet. Check adjustment of C29 ("B" Ant.) at 4800 kc and C30 ("A" Ant.) at 1400 kc.			

Alignment Procedure

**Test Oscillator**—For all alignment operations, connect the low side of the test oscillator to the receiver chassis and keep the oscillator output as low as possible to avoid AVC action.

Battery operation of the receiver is preferable during alignment; on AC operation an isolation transformer (117v./117v.) may be necessary if the test oscillator is also AC operated.

Critical Lead Dress

1. Dress all filament leads next to chassis.
2. Use short pigtail leads on components to V1, Pin 6.
3. Dress gang leads direct to avoid excess lead length.
4. Dress capacitor C17 across V3 socket to act as shield for C21.
5. Dress capacitors C3, C4 and C6 down to base between V1 socket and V2 socket, use short leads.
6. Use short pigtail lead on C16 to V3-2 and dress away from Pin 6.
7. Dress capacitor C24 down to base.
8. Twist loop antenna leads and dress into slots provided in cabinet—allow sufficient slack to permit rotation of antenna.
9. The "A" band series ant. coil (L3) and "B" band shunt ant. coil (L2) should be dressed away from chassis.

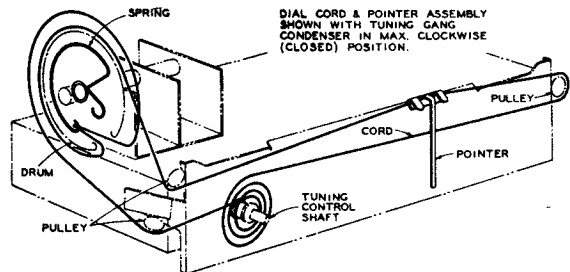

Dial-Indicator and Drive Mechanism

Chassis Removal

1. Remove control knobs (pull off).
2. Unsolder the two loop antenna leads.
3. Pull out battery and disconnect battery plug.
4. Remove the four chassis mounting screws, two at front sides and two at top rear.

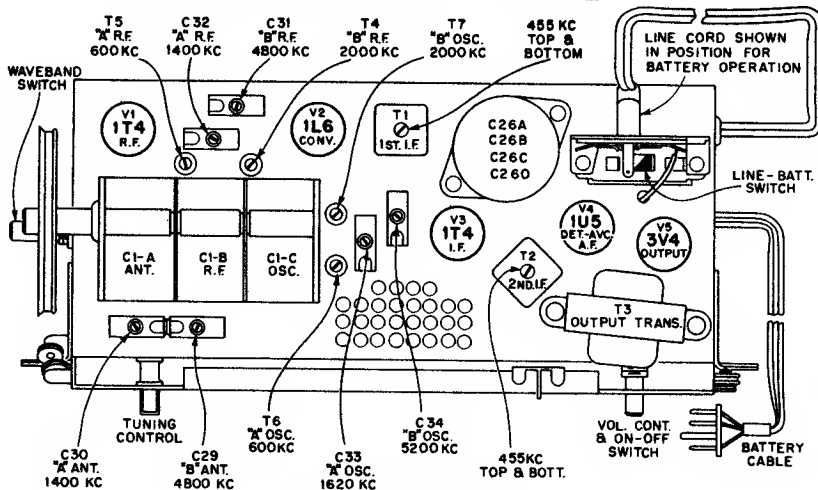

Tube and Trimmer Locations

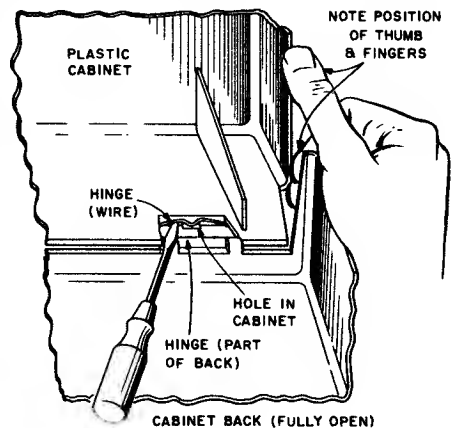

Removal of Cabinet Back

# RCA VICTOR 7-BX-8 Series

## Chassis No. RC-1162

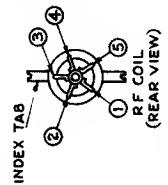

TUBE CURRENTS (MA) BATTERY OPERATION

PLATE	5-GRID
V1	.22
V2	.16
V3	1.25
V4	.08
V5	.013
V6	5.8
V7	1.25

CURRENTS SLIGHTLY HIGHER ON AC OPERATION.

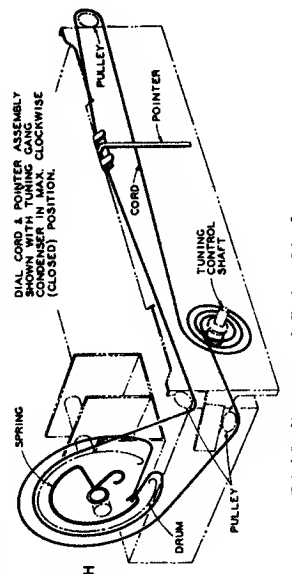
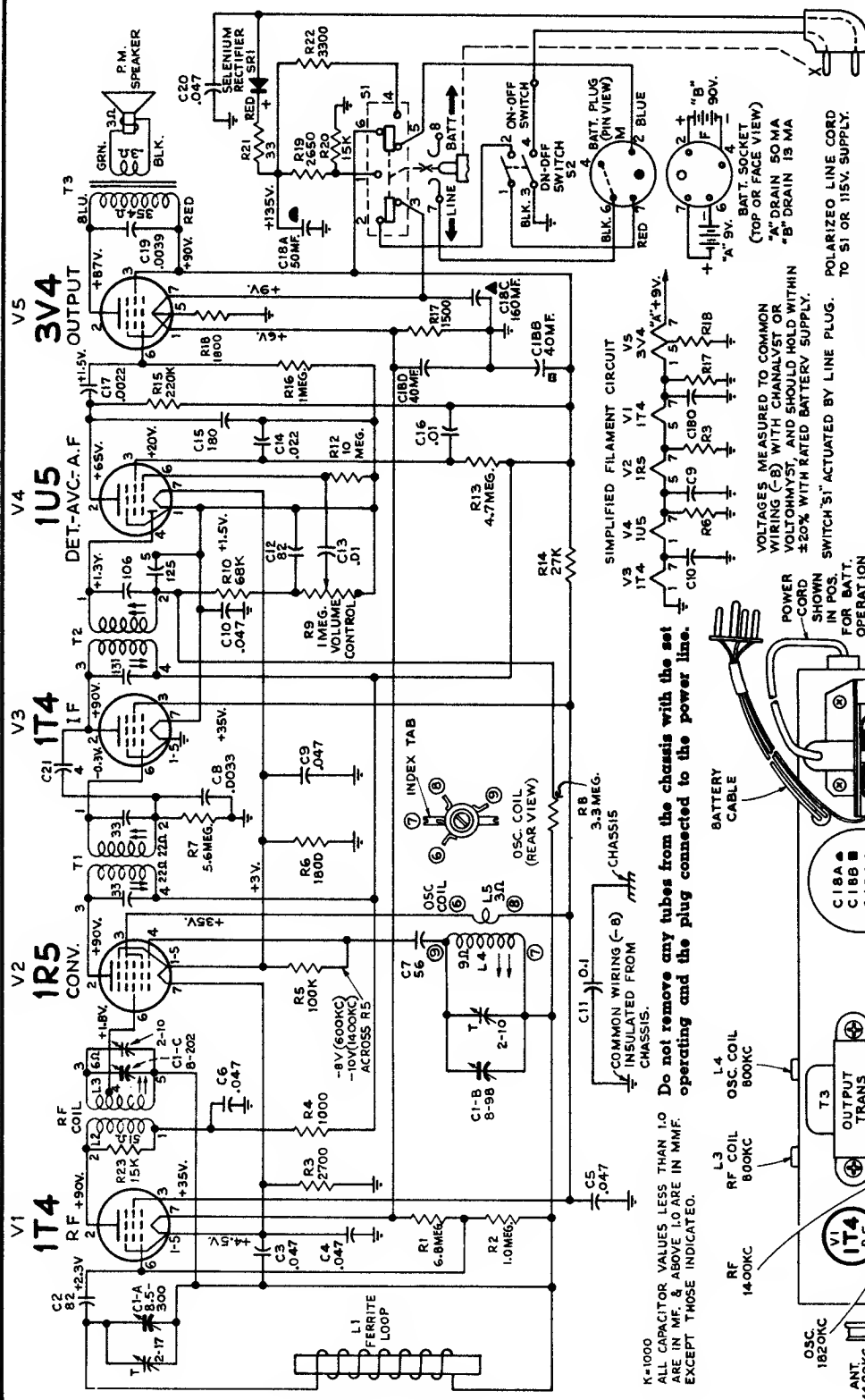

Dial-Indicator and Drive Mechanism

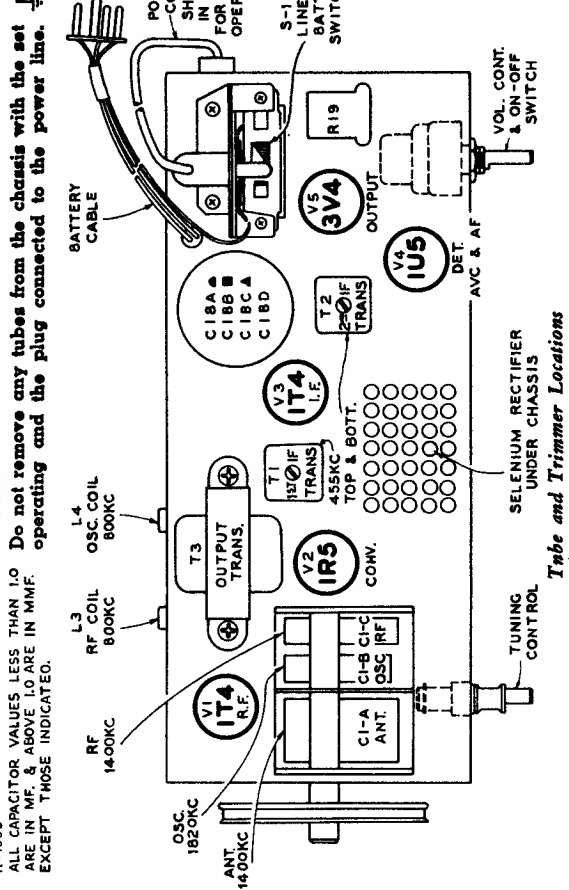

Tube and Trimmer Locations

K=1000  
ALL CAPACITOR VALUES LESS THAN 1.0 ARE IN MF. & ABOVE 1.0 ARE IN MMF. EXCEPT THOSE INDICATED.



# RCA VICTOR

## Portable Record Player MODELS 7-EMP-1J, 7-EMP-1K Chassis No. RS-152C

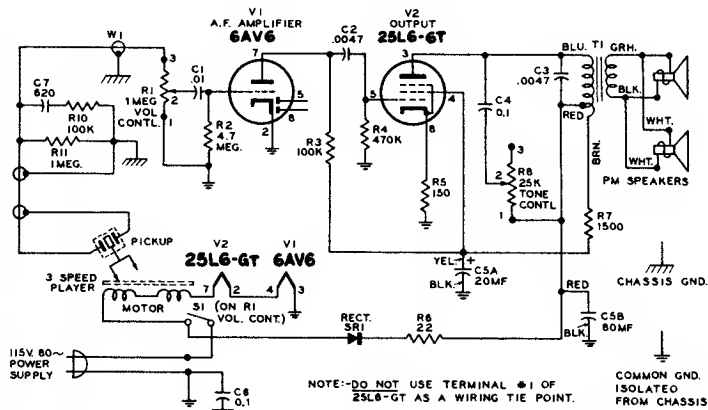

ALL RESISTANCE VALUES IN OHMS. K=1000  
ALL CAPACITANCE VALUES LESS THAN 1 μF MF & ABOVE 1 IN MMF UNLESS OTHERWISE NOTED.

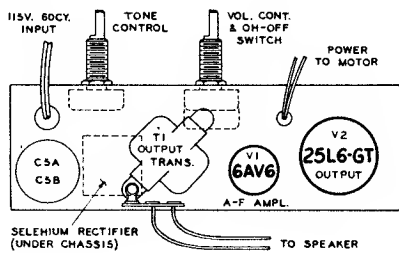

### STYLUS REMOVAL

Each stylus is mounted on a short pin which fits into a socket on the pickup. To remove a stylus, pull straight outward away from pickup; it is held in place only by pressure fit.

When replacing a stylus, be certain that the stylus coded with red paint points downward when "33-45" is visible on top of control lever. Likewise, the uncoded stylus should point downward when "78" is visible on top of control lever.

### OPERATION

Remove metal Needle Guard from the Tone Arm. Turn POWER-VOLUME knob clockwise about one-half turn. Allow brief warm-up.

Move SPEED CONTROL lever to "33," "45," or "78" position for correct Turntable Speed.

Place record over correct Spindle onto Turntable.

Turn NEEDLE SELECTOR to "33-45" before playing 33 1/3 or 45 r.p.m. records; to "78" before playing 78 r.p.m. records.

Set Tone Arm needle at start of record; adjust VOLUME and TONE as desired.

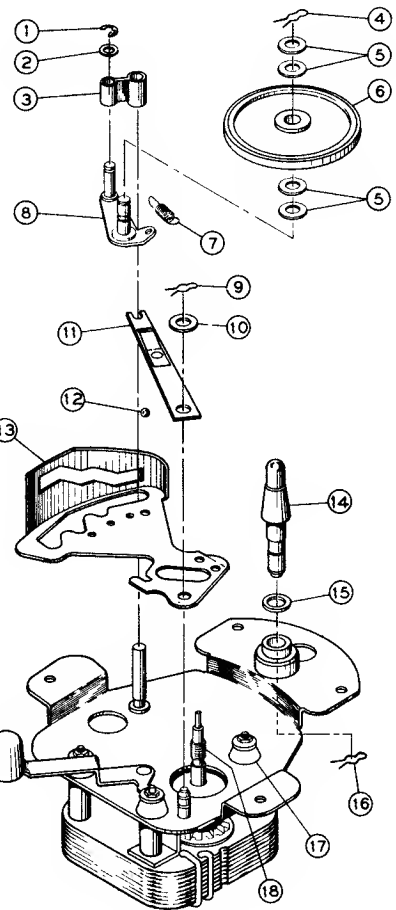

Motor Assembly

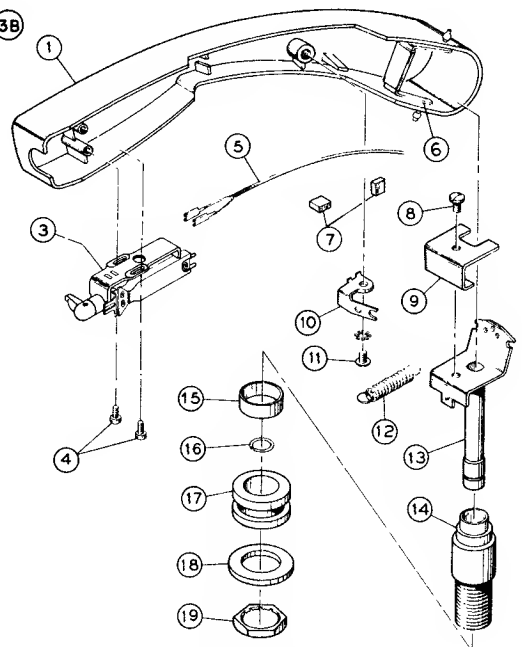
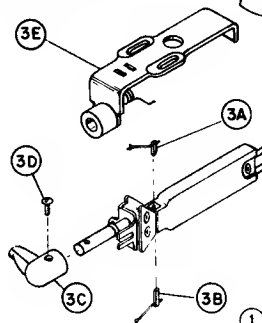

Pickup Arm Assembly

# RCA VICTOR

## MODEL 7-EP-2

Chassis No. RS-153

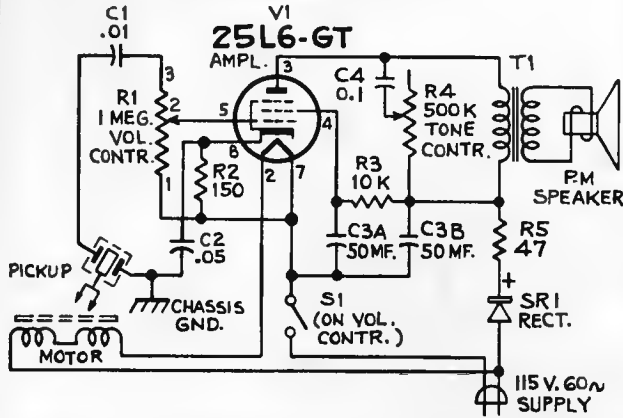

## MODEL 7-EP-45

Chassis No. RS-152D

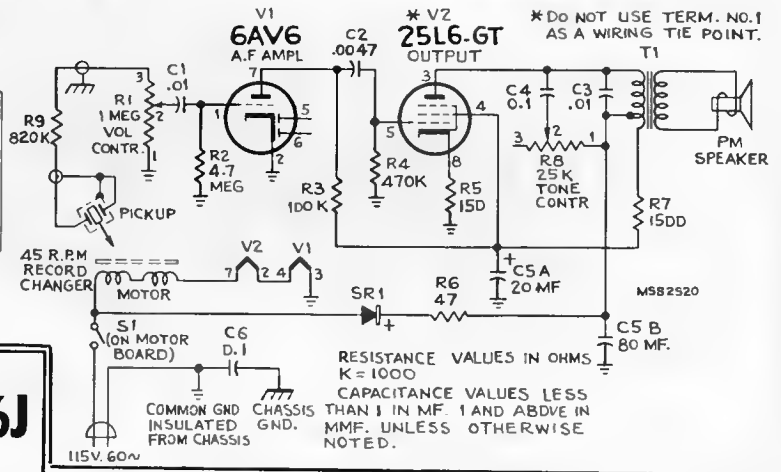
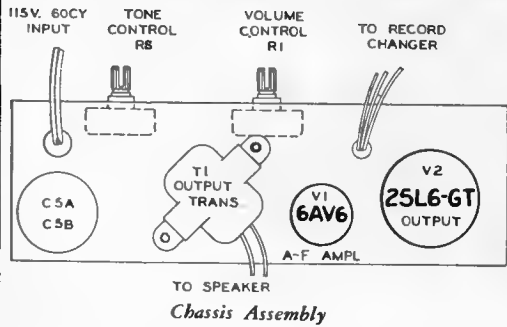
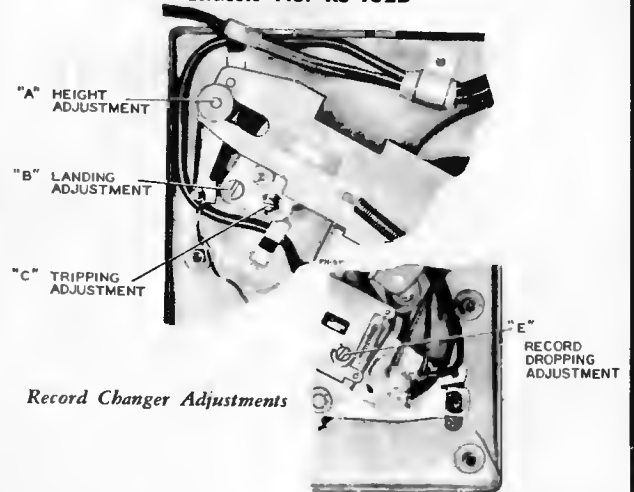

## MODELS 7-ES-6H, 7-ES-6J

Chassis No. RS-157A

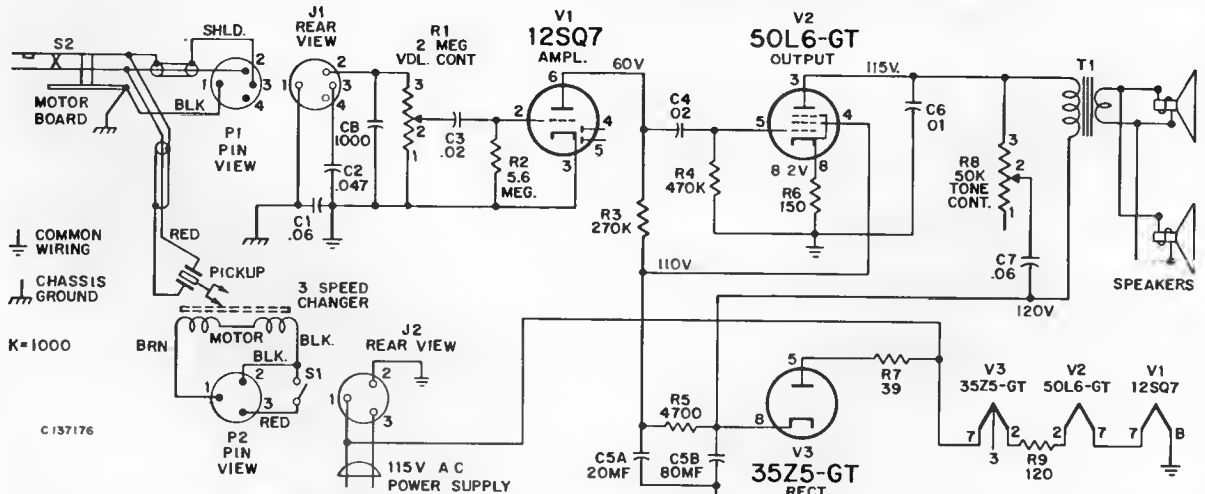



# RCA VICTOR

## MODEL 7-HF-5

Chassis No. RS-158

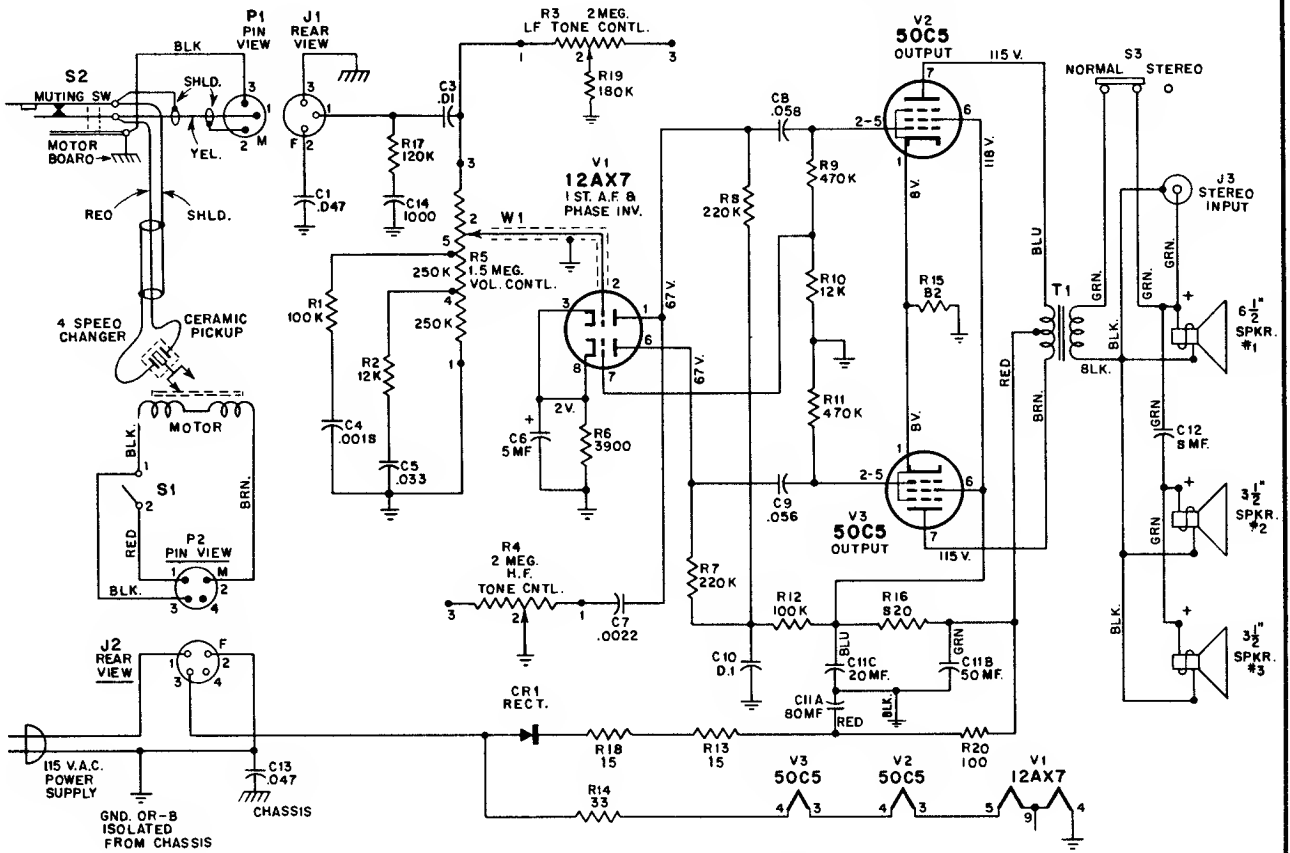

K=1000  
ALL RESISTANCE VALUES IN OHMS. ALL CAPACITANCE VALUES LESS THAN 1.0 IN MF AND 1.0 & ABOVE IN MMF EXCEPT AS INDICATED.

### CRITICAL LEAD DRESS

1. Dress all heater leads and power cord close to chassis and away from 12AX7 tube socket and phono input jack to maintain low hum level
2. Keep shielded lead W1, including shield connections, as short as possible.
3. Dress record changer power cable and pickup cable as far apart as possible to minimize hum pickup.

**NOTE**—The "ON-OFF" switch is not part of the volume control. The record changer must be "ON" for power to be applied to the amplifier.

The "NORMAL-STEREO" switch should be placed in the STEREO position when using the speakers of this instrument for stereophonic sound reproduction from another source.

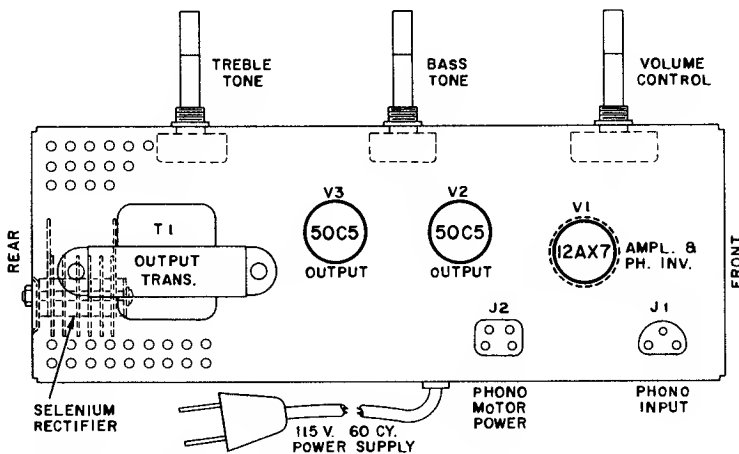

CATHODE CURRENTS	
V1	12AX7 ..... 0.25 MA
V2	50C5 ..... 51.4 MA
V3	50C5 ..... 51.4 MA

### STYLUS REPLACEMENT

The dual stylus is held in position by a spring clamp. To remove stylus, simply hold pickup sideways and pull spring clamp away from stylus and allow it to drop out. When inserting stylus, be certain that the small diameter rod holding the styli rests in the notch of the drive arm connecting to the cartridge element.

# High-Fidelity Record Player MODEL 7-HF-45

Chassis No. RS-159

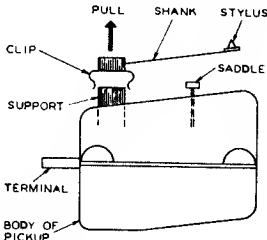

### STYLUS REPLACEMENT

To remove stylus, grip with tweezers at back end and pull away from the pickup. The shank of the stylus holder is imbedded in a rubber block which is set in a "U" shaped spring clip. This spring clip holds the stylus assembly to a plastic support. The shank of the stylus rests in a metal saddle. When replacing stylus, make certain that shank rests firmly in saddle.

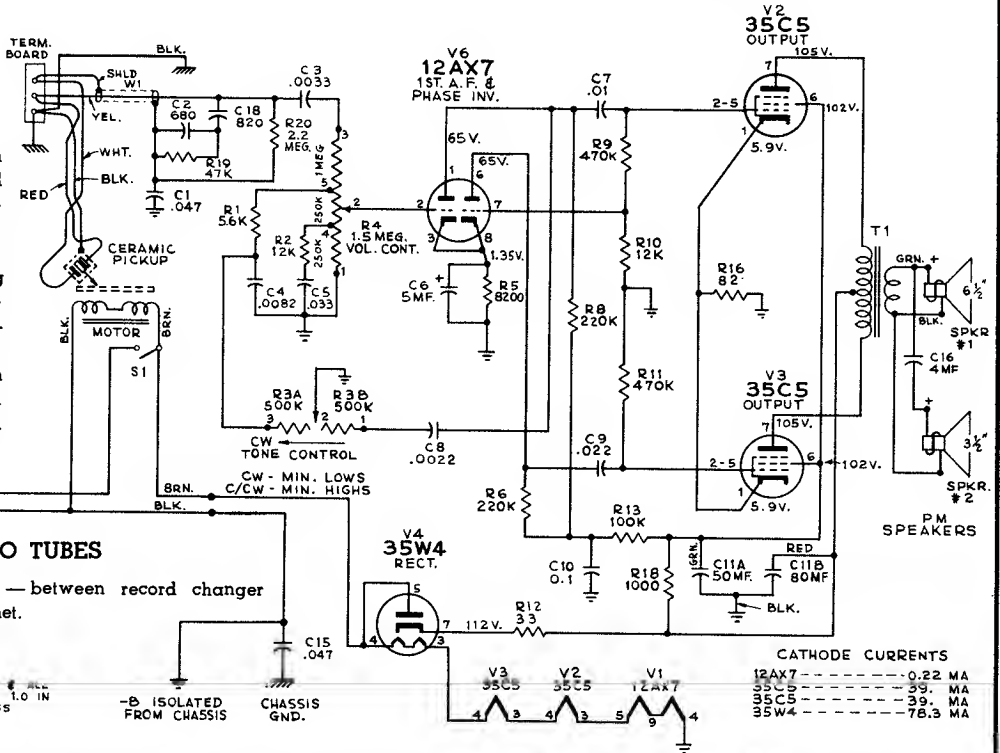

### ACCESS TO TUBES

Remove compartment panel—between record changer compartment and front of cabinet.

K = 1000  
ALL RESISTANCE VALUES IN OHMS & ALL CAPACITANCE VALUES LESS THAN 1.0 IN MF. & ABOVE 1.0 IN MMF. UNLESS OTHERWISE NOTED.

-B ISOLATED FROM CHASSIS  
CHASSIS GND.

CATHODE CURRENTS

12AX7	0.22 MA
35C5	39. MA
35C5	39. MA
35W4	78.3 MA

### ACCESS TO TUBES

Remove two knobs and rest instrument grille side downward. Detach pickup and motor cable plugs from chassis. Remove four slotted-head screws from bottom plate to release chassis.

### Automatic Record Player

# MODELS 8-EY-4DJ, 8-EY-4FK

Chassis No. RS-160

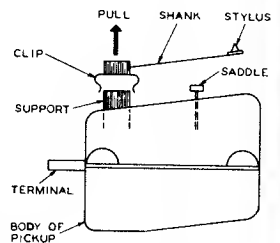
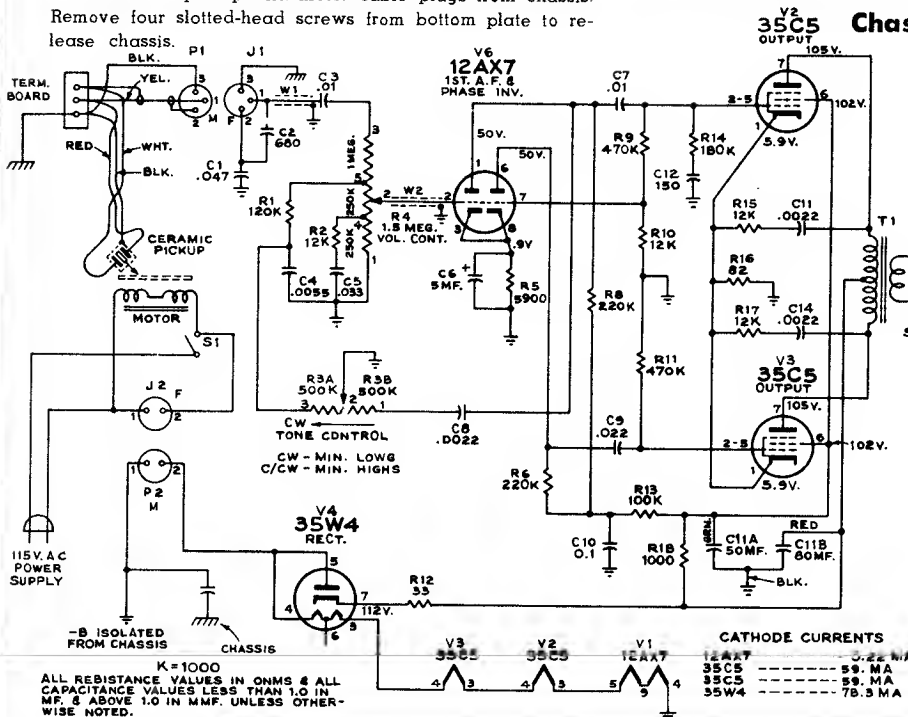

### STYLUS REPLACEMENT

To remove stylus, grip with tweezers at back end and pull away from the pickup. The shank of the stylus holder is imbedded in a rubber block which is set in a "U" shaped spring clip. This spring clip holds the stylus assembly to a plastic support. The shank of the stylus rests in a metal saddle. When replacing stylus, make certain that shank rests firmly in saddle.

K = 1000  
ALL RESISTANCE VALUES IN OHMS & ALL CAPACITANCE VALUES LESS THAN 1.0 IN MF. & ABOVE 1.0 IN MMF. UNLESS OTHERWISE NOTED.

CATHODE CURRENTS

12AX7	0.22 MA
35C5	39. MA
35C5	39. MA
35W4	78.3 MA



# RCA VICTOR

## 8-BT-7 Series, 8-BT-8 Series

Chassis No. RC-1169, RC-1169A

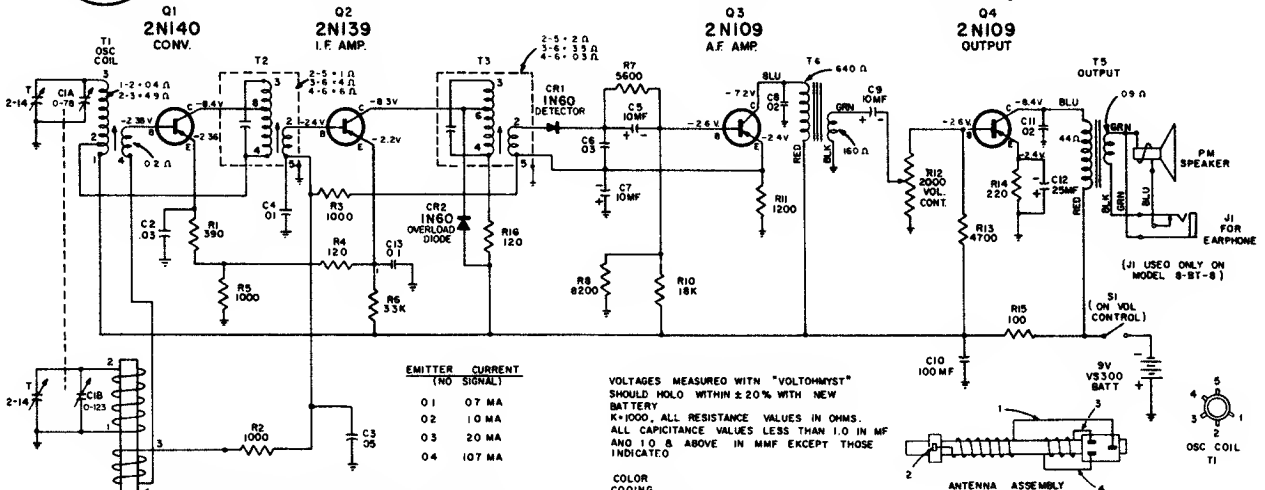

### FOR ACCESS TO PRINTED WIRING

Remove heat sink from output transistor. Disconnect leads to speaker and earphone jack.

Twist the board mounting lugs of the metal chassis so that they will pass through the slots of the circuit board. When reassembling, do not twist lugs more than sufficient to hold board to the metal chassis.

Separate the circuit board from the metal chassis at the battery end allowing it to "hinge" at the gang condenser end.

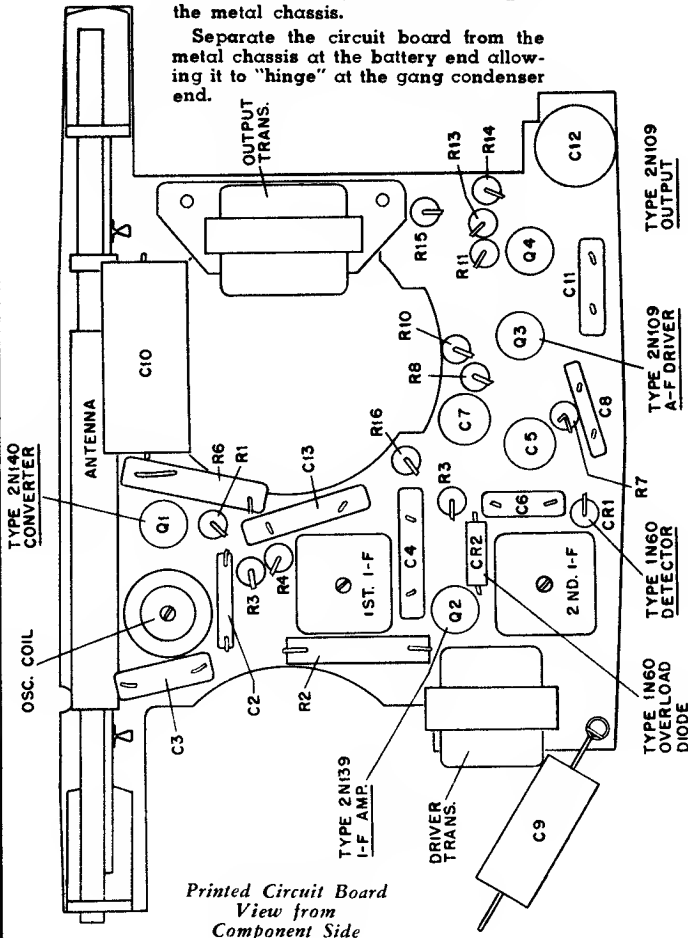

### ALIGNMENT PROCEDURE

**Test Oscillator**—For all alignment operations, connect the low side of the test oscillator to the "common positive" wiring and keep the oscillator output as low as possible to avoid AGC action.

Step	Connect High Side of Sig. Gen. to —	Sig. Gen. Output	Dial Pointer Setting	Adjust for Max. Output
1	Connection lug of C1-B (rear section of gang) in series with .01 mfd	455 kc	Quiet point near 1600 kc	I.F. trans T3 T2
2	Short wire placed near antenna for radiated signal	1620 kc	gang fully open	osc. trimmer C1-A
3		1400 kc	1400 kc signal	ant. trimmer C1-B
4		600 kc	600 kc signal (rock gang)	osc. coil T1
5	Repeat steps 2, 3 and 4			

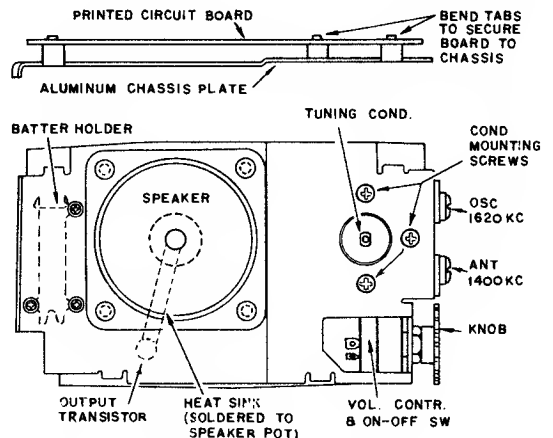

# RCA VICTOR

# MODEL 8-BT-10K

Chassis No. RC-1156A

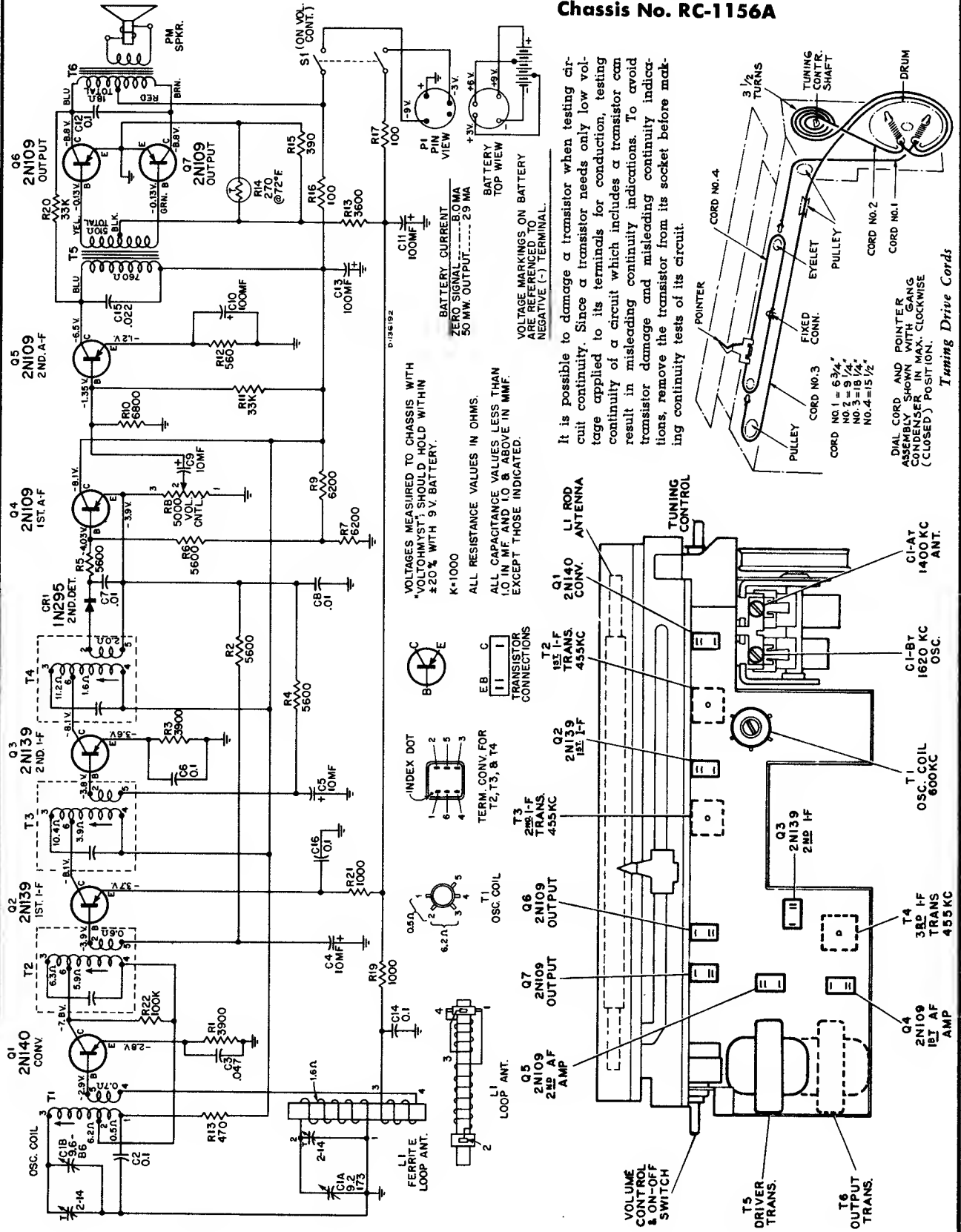

VOLTAGES MEASURED TO CHASSIS WITH "VOLTOHMIST"; SHOULD HOLD WITHIN  $\pm 20\%$  WITH 9 V. BATTERY.

K=1000

ALL RESISTANCE VALUES IN OHMS.

ALL CAPACITANCE VALUES LESS THAN 1.0 IN MF AND 1.0  $\mu$  ABOVE IN MMF. EXCEPT THOSE INDICATED.

It is possible to damage a transistor when testing circuit continuity. Since a transistor needs only low voltage applied to its terminals for conduction, testing continuity of a circuit which includes a transistor can result in misleading continuity indications. To avoid transistor damage and misleading continuity indications, remove the transistor from its socket before making continuity tests of its circuit.

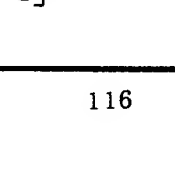
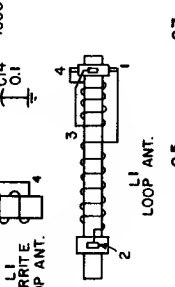
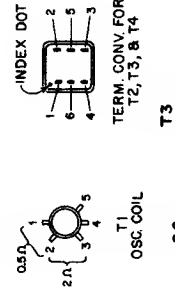
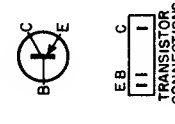
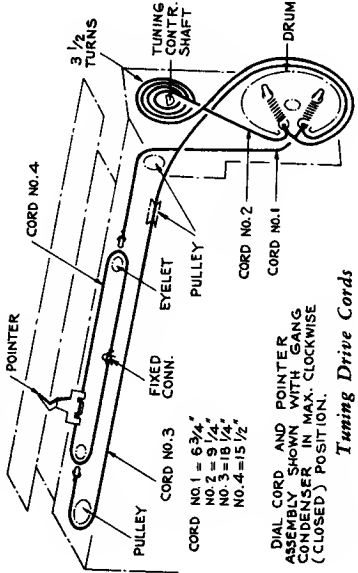

Transistor, Major Component and Trimmer Locations



RCA VICTOR

8-C-7 SERIES, 8-C-8 SERIES

Chassis No. RC-1166

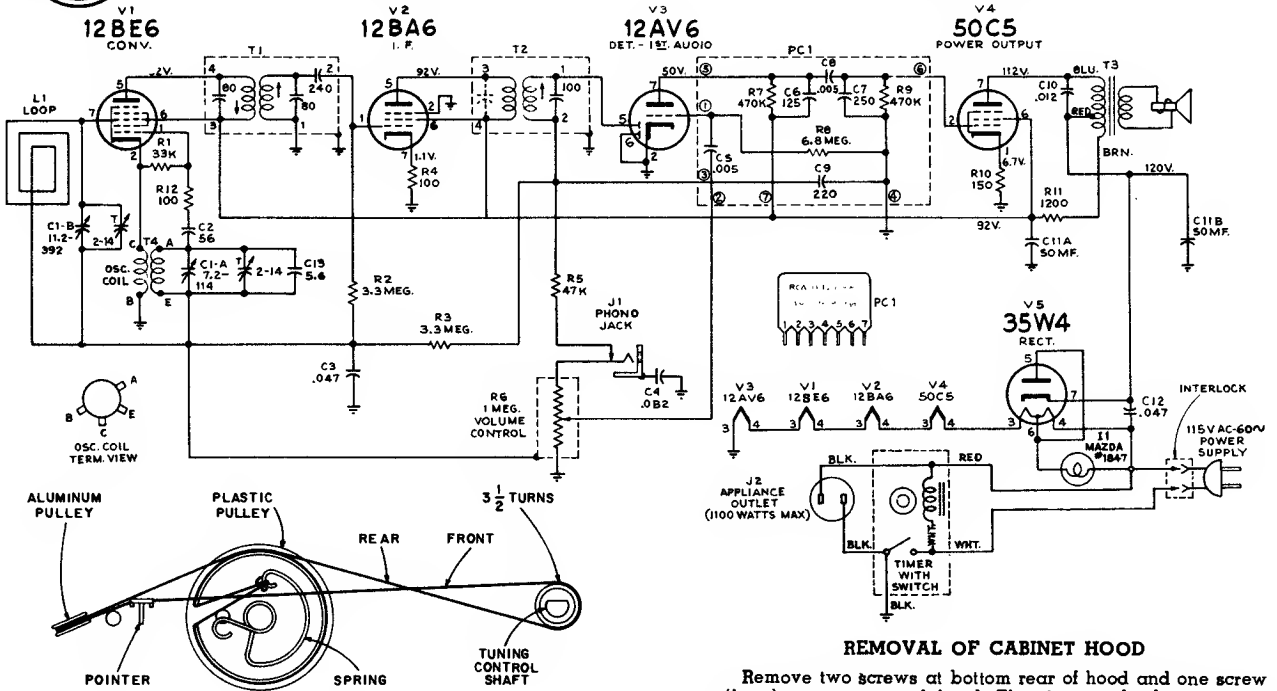

**REMOVAL OF CABINET HOOD**

Remove two screws at bottom rear of hood and one screw (long) at top rear of hood. The time-set knob is not removable. Pull bottom of hood away from chassis cradle to disengage power interlock. Lift hood up and to the rear.

**REMOVAL OF CHASSIS FROM CRADLE**

- Remove volume and tuning control knobs.
- Disconnect clock leads at chassis.
- Disconnect three speaker leads.
- Remove one screw at outside of cradle (close to speaker).
- Swing right end of chassis (as viewed from rear) to the rear of the cradle.
- Disengage chassis from cradle by moving endways.

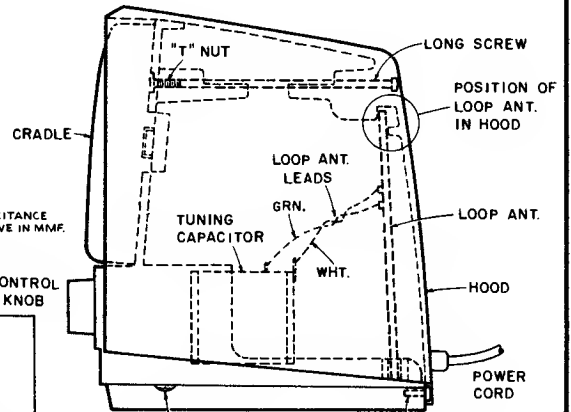

Cabinet Assembly

Complete Chassis Assembly — View from Component Side

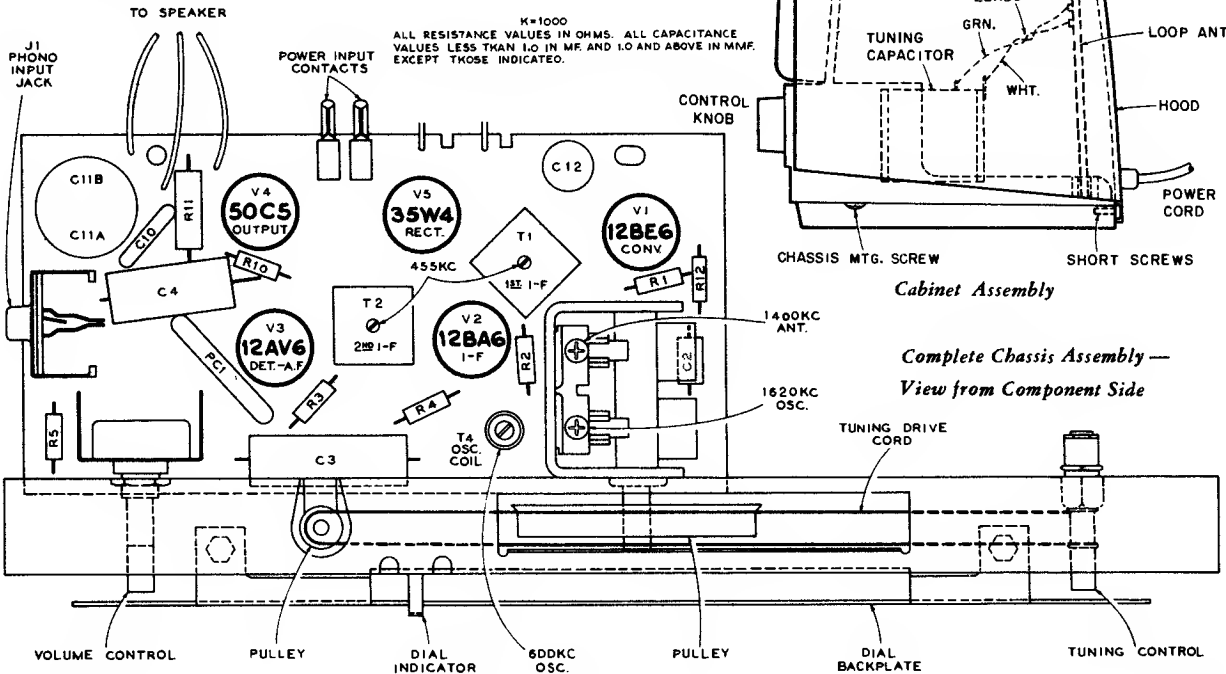

# RCA VICTOR

# 8-X-8 SERIES

Chassis No. RC-1167

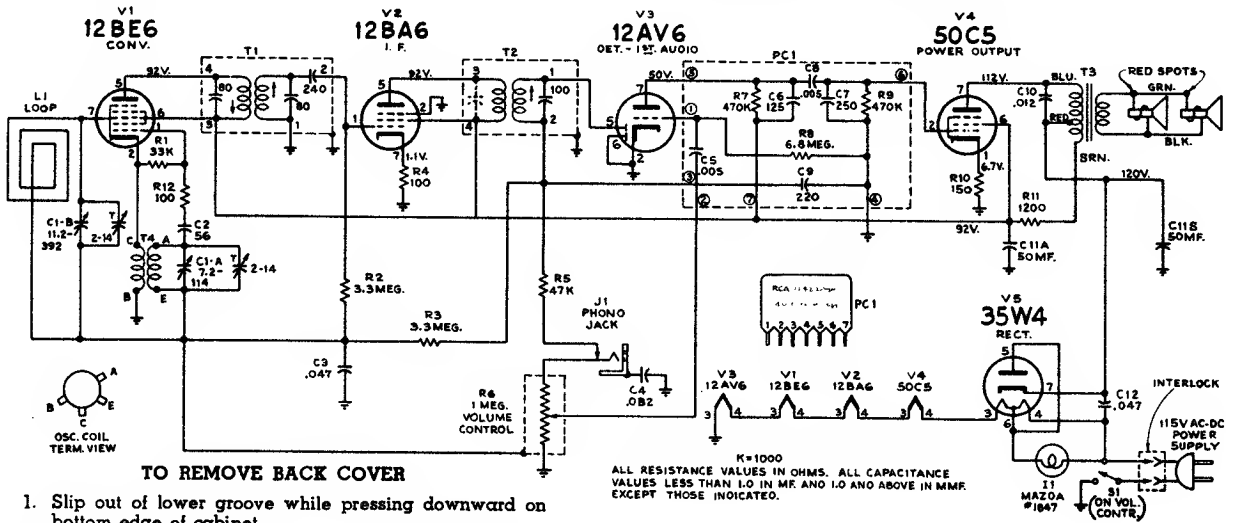

### TO REMOVE BACK COVER

1. Slip out of lower groove while pressing downward on bottom edge of cabinet.
2. Tilt outward to free interlock contacts, then drop from top grooves.

Avoid strain on loop connections.

### REMOVAL OF CHASSIS

1. Pull off volume control and tuning knobs.
2. Remove back cover.
3. Remove two screws holding dial assembly to cabinet.

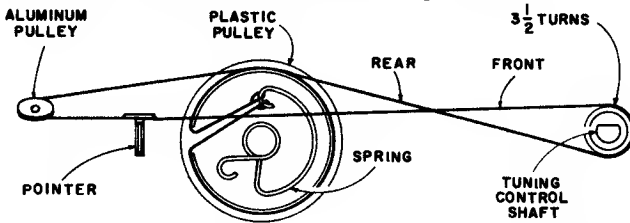

ASSEMBLY SHOWN WITH TUNING CONDENSER PLATES FULLY MESHED.

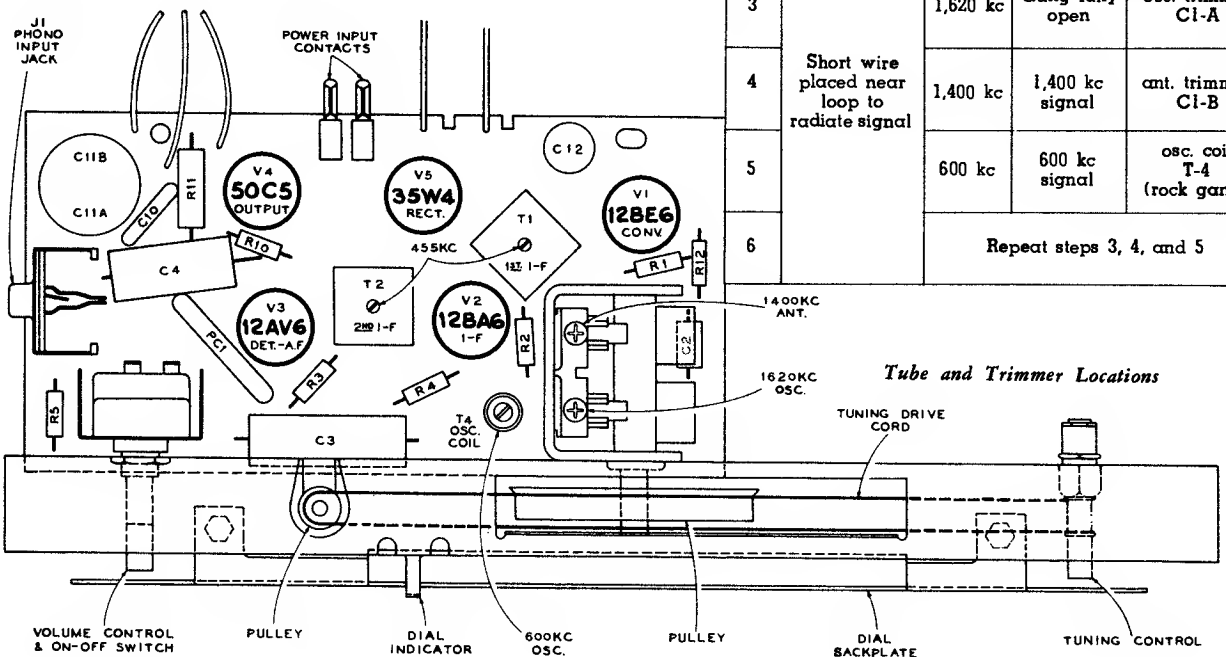

### Alignment Procedure

Dial Pointer Setting—With tuning condenser plates fully meshed, set left edge of dial pointer to the score mark on the dial backplate.

Step	Connect the high side of test-oscillator to—	Tune test-osc. to—	Turn radio dial to—	Adjust the following for max. output
1	12BA6 I-F grid through .01 mfd. capacitor	455 kc	Quiet-point 1,600 kc end of dial	T2 (top) 2nd I-F trans.
2	Stator of C1-B through .01 mfd.			T1 (top and bottom) 1st I-F trans.
3		1,620 kc	Gang fully open	osc. trimmer C1-A
4	Short wire placed near loop to radiate signal	1,400 kc	1,400 kc signal	ant. trimmer C1-B
5		600 kc	600 kc signal	osc. coil T-4 (rock gang)
6		Repeat steps 3, 4, and 5		

### Tube and Trimmer Locations



# RCA VICTOR

## RP-205 Series Automatic Record Changers

(This service material is presented below and continued on the next twenty-one pages)

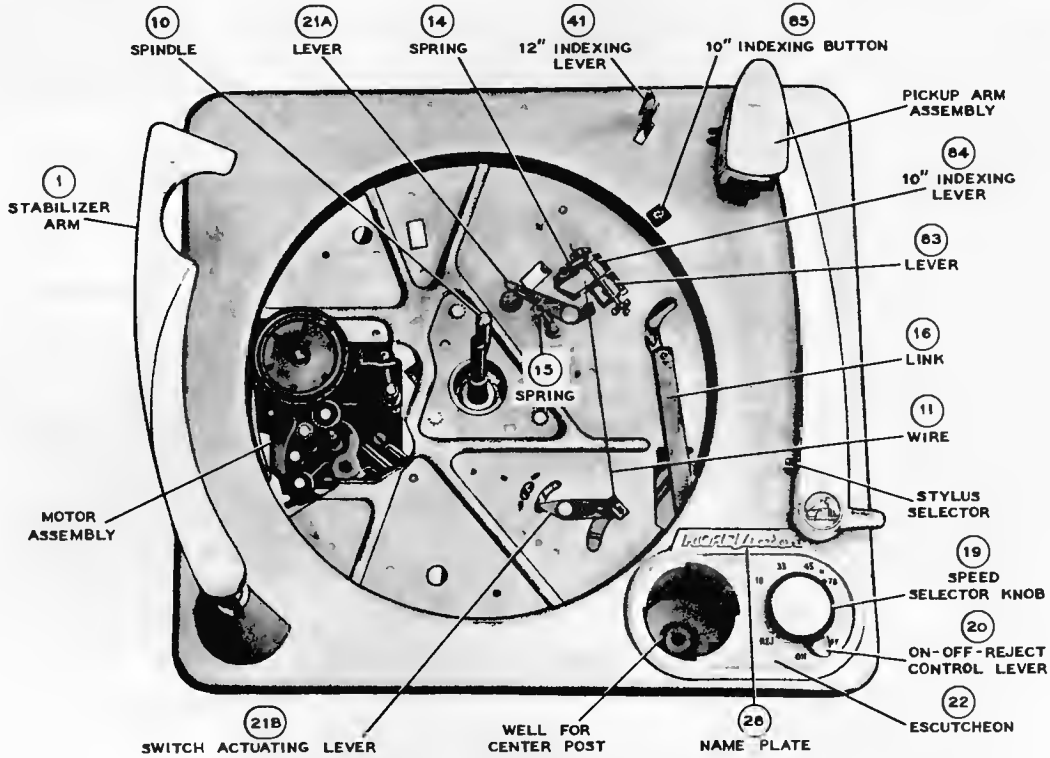

Figure 2—Top View of RP-205-2 with Turntable Removed

Other models differ in appearance of pickup arm.

### GENERAL DESCRIPTION

The RP-205 Series record changers are four-speed mechanisms designed to play, in automatic sequence, a stack of 7", 10" or 12" records, or 10" and 12" records intermixed. The mechanism will shut off automatically after playing of the last record.

Record separation is accomplished by movement of a finger in the center spindle. This finger directly separates records having a 1/4" centerhole and actuates the knives and shelves of the centerpost used for the playing of records having a 1 1/2" centerhole.

The tripping method used is the acceleration or velocity type in which the trip lever causes a trip pawl to engage a projection on the turntable hub and start the mechanism into cycle. If the record being played causes the pickup arm to move inward at a constant rate without acceleration, a point will be reached where a constant-diameter trip is effected.

A well is provided on the record changer for storage of the centerpost when it is not in use. The centerpost may be firmly secured, after placing it in the well, by pushing down.

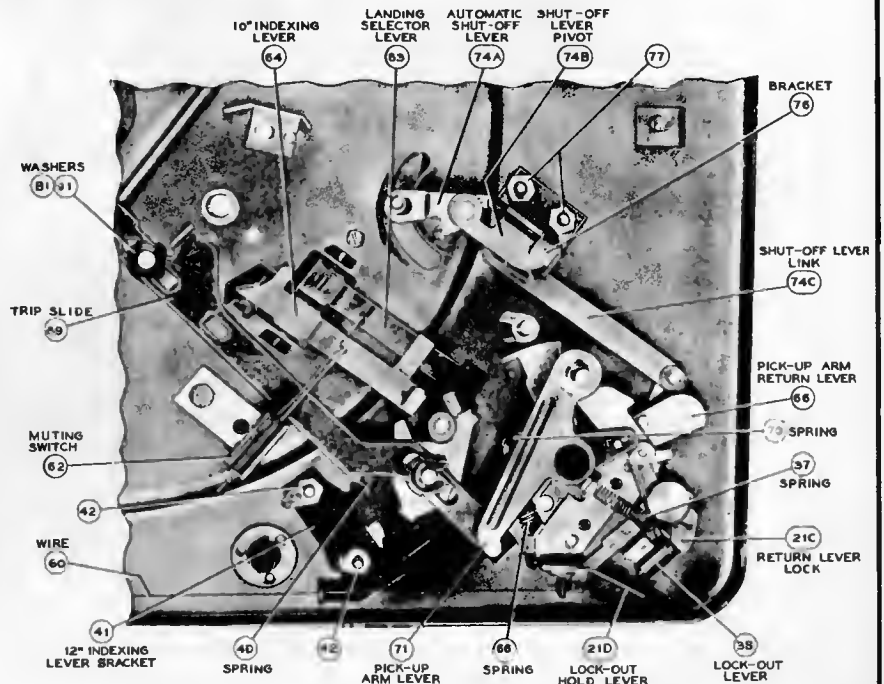

Figure 3—Partial Bottom View of RP-205-2 with Cycling Slide Removed

RCA Victor Record Changers RP-205 Series, Continued

ADJUSTMENTS

LANDING ADJUSTMENT (Fig. 4)

When the pickup arm is mounted the clamp screw should seat in the depression in the pickup arm lever shaft, then only one landing adjustment is necessary. The landing position of the stylus is adjusted by means of the slotted nut at the side of the pickup arm support bracket. When adjusted for correct landing on one size record (12" record preferably if convenient), the landing position for the other two sizes is automatically maintained.

Lift and turn the record stabilizer arm outward. Place a 12 inch or 78 rpm record on the turntable. Turn the speed control knob to the 78 rpm position and the control lever to the reject position. Rotate the turntable by hand until the stylus is just ready to set on the record. Then turn the landing adjustment screw so the stylus will set on the record midway between the outer edge and the starting groove.

Slight "touch up" or a compromise in this adjustment may be necessary so that the pickup will land correctly on all three size records when operating automatically.

PICKUP ARM HEIGHT ADJUSTMENT (Fig. 4)

The pickup arm height during cycle is adjusted by means of the hex head screw, located in the pickup arm.

Turn control knob to "REJ" and rotate turntable by hand until arm has risen to its maximum height. Adjust screw so that stylus is 1 3/8" above turntable.

RECORD DROPPING ADJUSTMENT

The eccentric stud (Ill. No. 101, Fig. 5) on the end of the cycling slide controls the time during cycle at which the record drops to the turntable.

Adjust the position of the stud so that the record drops to the turntable when the pickup arm has moved to its maximum

outward travel. If the record drops too soon it will strike the pickup arm. If timed too late the record may not drop.

10" INDEXING LEVER ADJUSTMENT

The rubber tip (Ill. No. 85, Fig. 2) on the 10" indexing lever is molded onto a threaded shaft and provides a means of adjustment for proper indexing.

Adjust rubber tip so that it will be depressed at mid-cycle approximately 1/16" by a 10" or 12" record when the record rests on the turntable. The rubber tip should not touch the record when the mechanism is out of cycle.

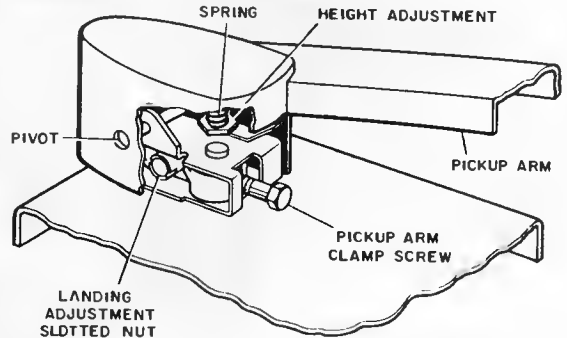

Figure 4—Pickup Arm Height and Landing Adjustments

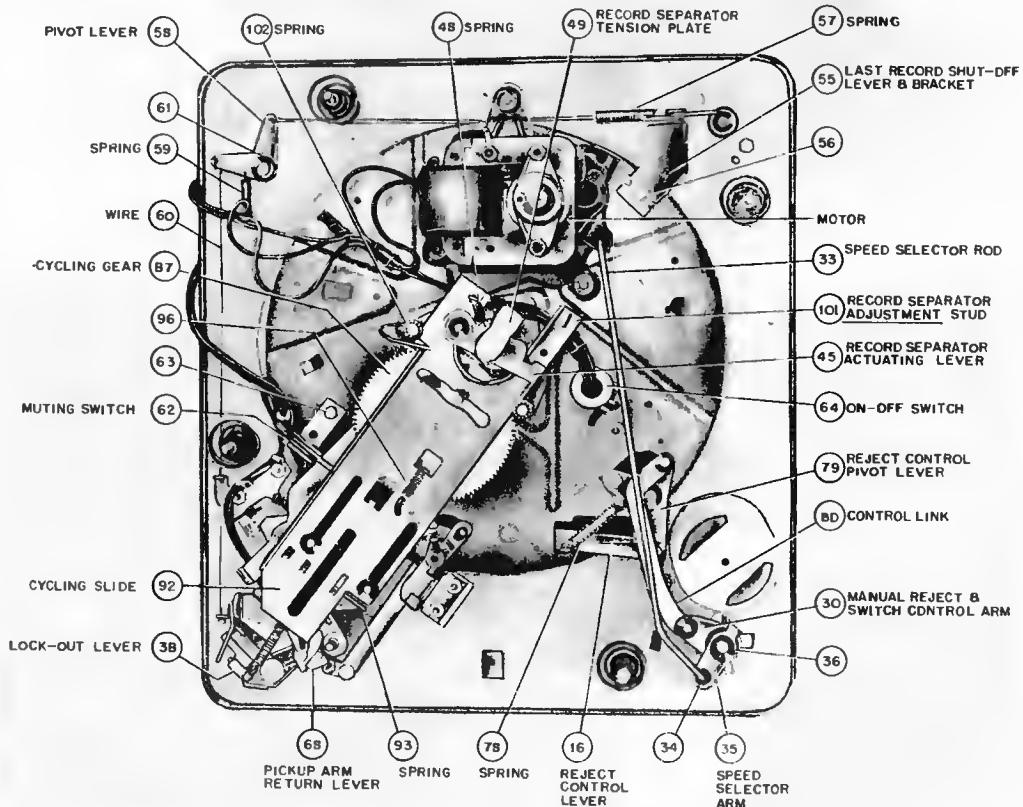

Figure 5—Bottom View of Mechanism RP-205-2

RP-205-1, RP-205-3 and RP-205-4 use a larger motor (4 pole) and a different speed control rod (item 33).  
RP-205A-1 and RP-205A-2 use a voltage change switch.



RCA Victor Record Changers RP-205 Series, Continued

CYCLE OF OPERATION

NOTE: In the cycle of operation it is assumed the mechanism has stopped automatically with the pickup arm on the rest.

PRELIMINARY PROCEDURE

Place a stack of records (10" or 12") on the spindle (intermixed if so desired). Place the record stabilizer arm so it rest on the records.

OR

If playing 7 inch records first place the large centerpost over the regular spindle, then proceed as for large records.

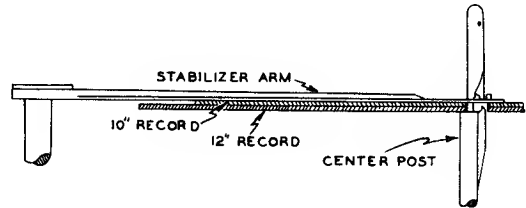

MANUAL START

Push control lever (20) in a clockwise direction to the "On" position. This movement of the control lever through the linkage of levers (30, 80, 79 and 21B) results in actuating the power switch (64) and the motor starts running. Then push control lever further clockwise to "Rej." position and permit it to return to the "ON" position automatically.

This movement of the control lever to the "Rej." position transmits a force from lever (21B) through wire (11) to lever (21A). The lever (21A) then contacts and applies force against turned up lance (89A) of trip slide (89) and pushes the trip slide in an outward direction away from the turntable spindle.

Tab (89B) of trip slide makes a contact with trip pawl (87E) thereby moving engagement pawl (87F) into position where it is in the path of the projection on the turntable hub. As the turntable rotates, the projection on its hub momentarily strikes the engagement pawl (87F) causing the cycling gear (87) to rotate sufficiently so that the cycling gear teeth and those of the hub (6A) will mesh.

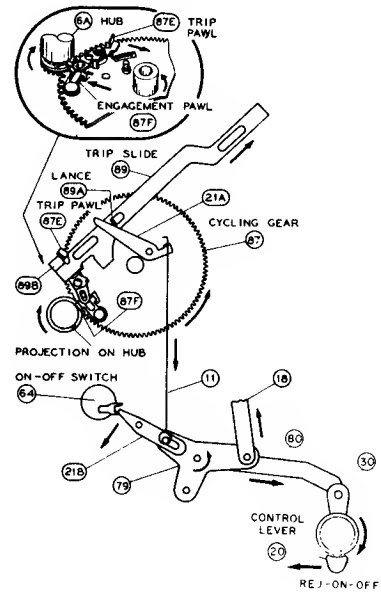

CYCLING STARTS

As the cycling gear (87) rotates, the stud (87G), which is mounted on the bottom of the gear and extends through and rides in the elongated slot in the cycling slide (92), pushes the slide outward away from the spindle.

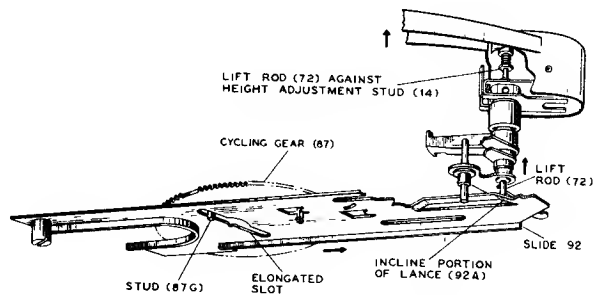

PICKUP ARM RISES AND MOVES OUT

Almost immediately after the slide starts on its outward movement the pickup arm lift rod (72) rides up the inclined portion of the lance (92A), forcing the lift rod upward against the height adjustment stud (14) causing the pickup arm to rise.

About this same time the cycling gear has rotated sufficiently for the trip pawl to slide over the edge of a small piece of metal extending from the bottom of the motor board and resets itself to prevent the mechanism from tripping continuously.

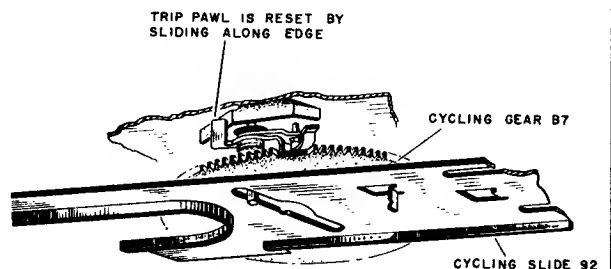

RCA Victor Record Changers RP-205 Series, Continued

CYCLE OF OPERATION (Cont.)

PICKUP ARM RISES AND MOVES OUT (Cont.)

Further movement of the slide (92) results in a contact between the straight spring wire (93 attached to the slide) and the bottom stud (71A) on the pickup arm lever (71) thereby rotating the lever and starting the pickup arm on its outward movement. At this time the upper stud (71B) slides over latch (68A) and locks the pickup arm return lever (68) to the pickup arm lever (71). This locked condition causes both the pickup arm lever and the pickup arm return lever to rotate as a unit in opposition to the force applied by the pickup arm return spring (66). Since the pickup arm is connected to the pickup arm shaft, the pickup arm follows.

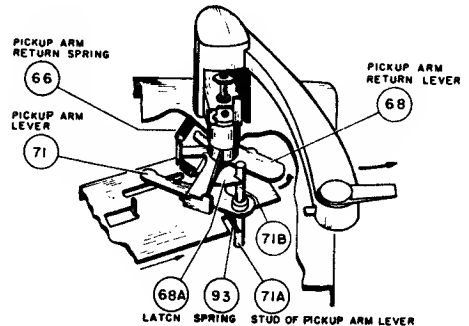

While the pickup arm lever and the pickup arm return lever are latching together, and the cycling slide is approaching the end of its outward travel the stud (92B) (mounted on cycling slide) contacts actuating lever (38) and unlatches (21C). It is important at this time to realize that the unlatching of (21C) is necessary for pickup to land on the record, it would otherwise land in the rest position.

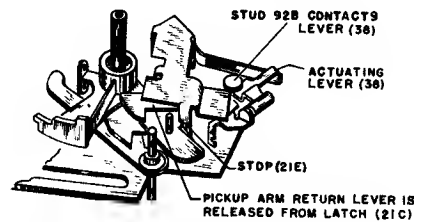

As the slide reaches the extreme end of its outward travel (mid cycle position) the pickup arm lever (71) is pushed to a position where one end of the lever is against the stud (extending from the bottom side of the motor board) while the stud on the other end of the lever remains against the wire takeup spring (93).

The pickup arm lever (71) held in this wedged position (when the pickup arm is in its outermost position) produces a positive stabilizing action for the pickup arm as the record drops to the turntable. However, to prevent erratic landing, it is necessary that latch (68A) remains latched so that pickup arm lever and pickup return arm lever remain coupled together as the pickup moves in for landing.

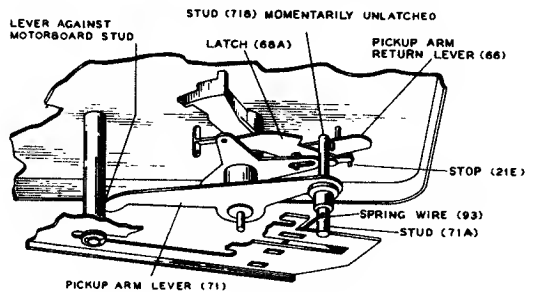

RECORD DROPS TO TURNTABLE

Just before slide (92) reaches its maximum travel outward, the eccentric stud (101) (mounted on the under side of the slide) contacts and pushes spindle operating arm (45).

The lower end of the push-off finger, extending through the hole in the operating arm, rides along with the arm. Since the push-off finger is pivoted about a pin driven through the spindle, the upper end of the finger moves in a direction to push the record off the shelf of the spindle and the record drops to the turntable. The retainer (10A) effects record separation by blocking the adjacent record, thereby preventing it from being pushed off the shelf of the spindle. After the record drops to the turntable (mid-cycle position) the cycling slide (92) starts on its return trip to the normal out-of-cycle position.

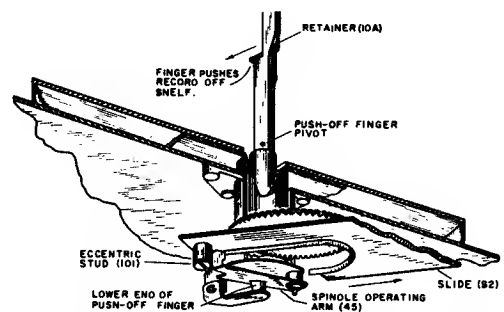

THE PICKUP LANDS ON RECORD

During the return travel of the cycling slide the wire spring (93) (attached to the slide) moves away from the stud (71A) (on the pickup arm lever) permitting the pickup arm lever and the pickup arm return lever (which are locked together) to direct the movement of the pickup arm inward.

The pickup arm is pushed inward by the pickup arm return lever, until the pickup arm return lever is blocked by the landing selector lever (83) which contacts one of three steps formed in the return lever. Each step corresponds to one of the three (7, 10 or 12 inch records) landing positions.

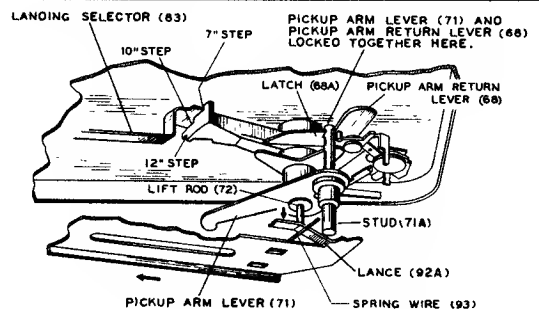

RCA Victor Record Changers RP-205 Series, Continued

CYCLE OF OPERATION (Cont.)

THE PICKUP LANDS ON RECORD (Cont.)

As the pickup arm return lever directs the movement of the pickup arm, the stud (68B) on the pickup arm return lever moves away and permits the spring (73) to raise the end (74A) (of switch link shut-off assembly) so as to clear the escape lever (92D). Otherwise the mechanism would actuate switch (64) and motor would stop.

When the pickup is directly above the landing position the cycling slide has returned sufficiently for the pickup arm lift rod to ride down the inclined portion of the lance in the slide and the pickup stylus sets on the start of the record.

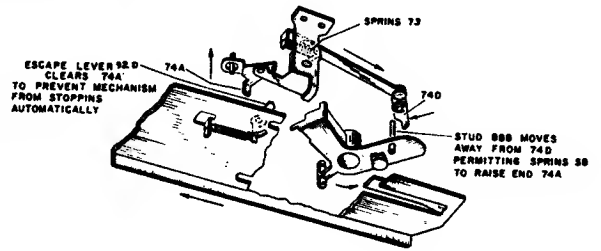

An instant before the pickup sets on the record, the stud (92B) located on the extreme end of the cycling slide contacts the end of the actuating lever (69), unlatching the pickup arm lever from the pickup arm return lever. This allows the pickup arm to become free in its movement at the time the stylus contacts the record. At this time the cycling cam has not quite completed its return travel.

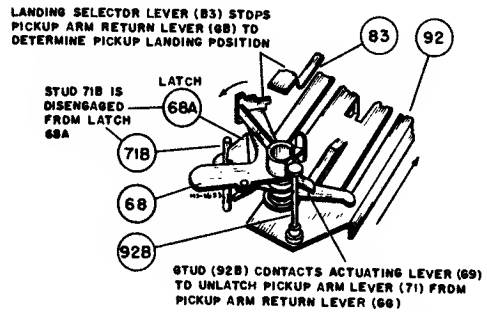

The remaining short travel results in the stud (92B) carrying the actuating lever (69) sufficiently that the pickup arm return lever is pulled away from the landing selector lever (83). The stud (68B) on pickup arm return lever (68) is then latched to pickup arm latch (21C) and remains latched throughout the playing cycle.

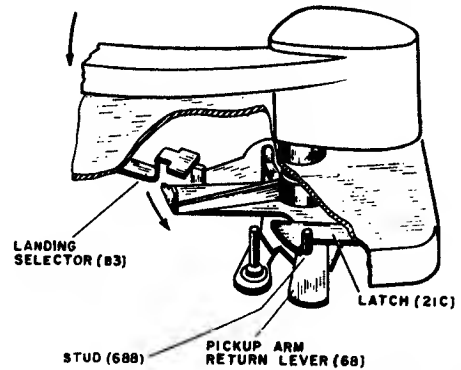

CYCLING COMPLETED

As the cycling gear is completing its cycle, a stud (87H) located on the top of the cycling gear contacts and pulls the trip slide (89) back to the position for the next tripping.

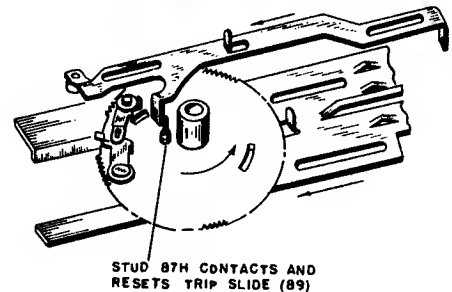

The final phase of the change cycle is completed after the cycling gear has rotated sufficiently so that the teeth in the gear on the turntable hub run off the last tooth at the cut-away section of the gear. At this time the stud (87G) riding in the elongated slot in the cycling slide, drops into the stop notch and the cycling gear stops rotating.

The muting switch is opened at this time by a tab on the cycling slide.

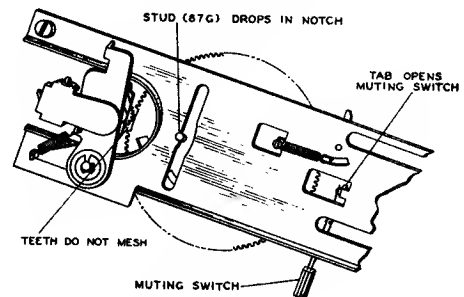

RCA Victor Record Changers RP-205 Series, Continued

CYCLE OF OPERATION (Cont.)

RECORD PLAYS

As the record plays and the pickup moves inward, the pickup arm lever (71) contacts trip slide (89) and pushes the slide outward away from the center post. The other end of the trip slide contacts and moves trip pawl which, through a friction clutch arrangement, moves trip engagement pawl.

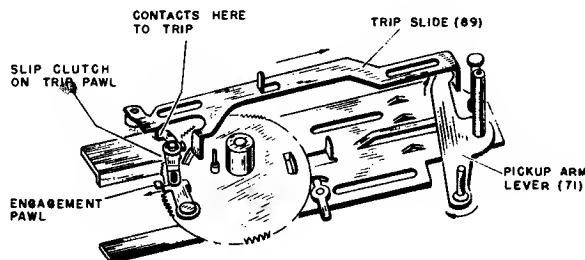

While the record continues to play the pickup moves in at a constant rate of speed until the sloped side of the engagement pawl lightly contacts the projection on the turntable hub. When this contact occurs the engagement pawl is pushed back with each rotation of the turntable, providing the pawl has not moved in so far that the contact is made on the leading edge. If the inward movement of the pickup should accelerate rapidly, as it does when the stylus leaves the recorded section and enters the eccentric groove of the record, the trip engagement pawl moves in too far before the turntable has made a complete revolution; consequently the projection on the turntable hub makes contact on the side of the engagement pawl. This firm contact rotates the cycling cam sufficiently to have the teeth of the turntable hub and the cycling gear engage to start a change cycle. This tripping procedure is referred to as an acceleration trip. However if the pickup continues to move inward at a constant rate, there is a limit at which the edge of the engagement pawl will make a firm contact with the projection on the turntable hub and a constant diameter trip is effected.

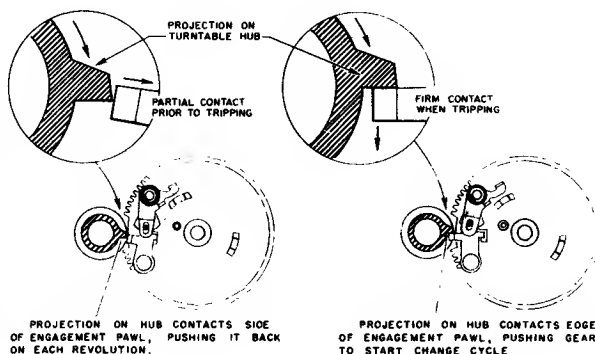

As the cycling cam is carrying the mechanism through cycle a tab on the bottom of the motorboard will contact and reset the trip pawl mechanism so the changer will not recycle without playing the next record.

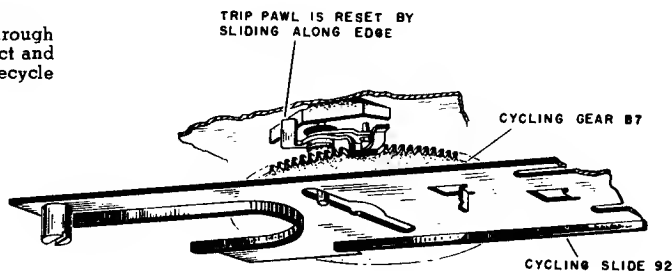

INDEXING FOR PICKUP LANDING POSITION

As stated previously the pickup landing position for 7, 10 and 12 inch records is determined by the contact of the landing selector lever (83) and the various steps in the pickup arm return lever.

There are two depressions (lances) in the cycling cam that play an important function in pickup landing position indexing. The depression located adjacent to the trip pawl mechanism provides a means of indexing for 7" records. This is accomplished by permitting the end of the 10" indexing lever (84) to drop down in the depression as the cam rotates causing the other end to push the landing selector lever (83) upward as far as it will go. The pickup arm return lever will then make contact with the landing selector lever (83) on the upper step and the pickup will land on the start of a 7" record.

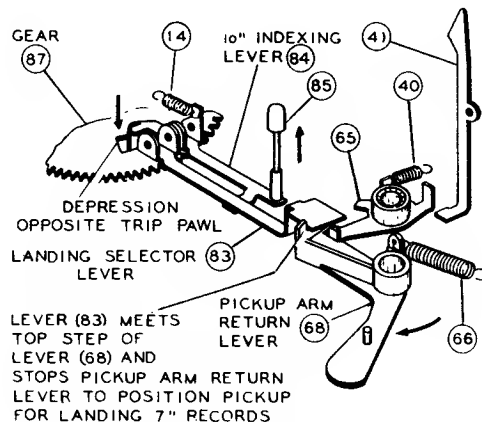

RCA Victor Record Changers RP-205 Series, Continued

CYCLE OF OPERATION (Cont.)

INDEXING FOR PICKUP LANDING POSITION (Cont.)

When either a 10" or a 12" record is lying on the turntable the rubber end of the 10" indexing lever (84) is prevented from rising even though the other end of the lever tends to drop into the depression in the cam. Consequently the landing selector lever is only pushed up far enough, that the pickup arm return lever makes contact with the second step and the pickup will land on a 10" record.

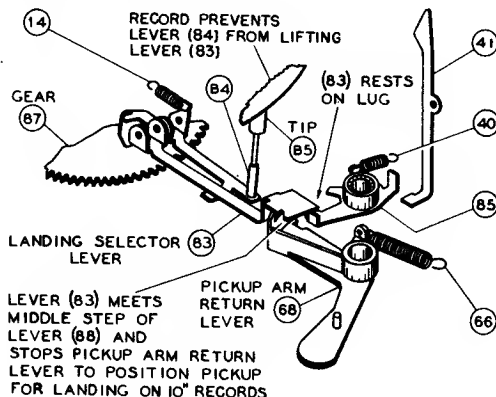

However if a 12" record drops to the turntable the edge of the record strikes the 12" indexing lever (41) and causes the other end of the lever to rotate the selecting lever (65) sufficiently to permit landing selector lever (83) to drop off the tab (65A) and land on tab (65B). With the landing selecting lever in this position, it will make contact with the lower step in the pickup arm return lever stopping the pickup arm on its inward movement, so the pickup will then land on the start of a 12" record.

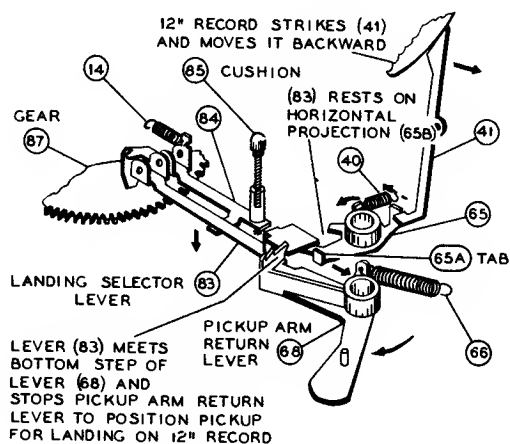

The other depression (lance) opposite the trip pawl mechanism provides a means of raising the end of the indexing selector (83) to the top of the tab (65A) so the landing is automatically returned to the 10" landing position. This means of automatically returning the pickup landing to 10" position makes it possible to play 10" and 12" records intermixed.

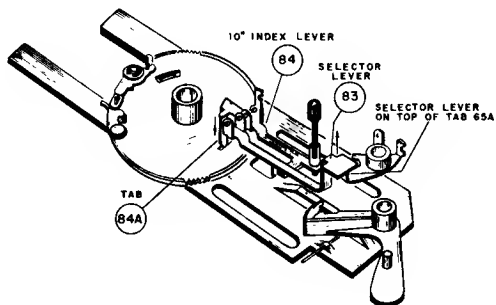

STARTING PROCEDURE OF "LAST-RECORD-STOP"

The stabilizer arm not only performs the function of stabilizing the records setting on the spindle shelf but it also serves the purpose of actuating the automatic stopping feature.

As the last record of the stack drops to the turntable the record stabilizer arm (1) drops and actuates the stop arm (55). This stop arm in turn applies force to the stop lever (21D) through spring (57), lever 58 and connecting wire (60). At this moment the cycling slide has reached its outermost position and the end (21D) is pushing upward on escape lever (38) but is held from doing so by the knobbed end on the stud 92B which retards the movement of the escape lever (38) until the cycling slide has started on its return trip.

The escape lever then raises and the pickup lands and plays the last record.

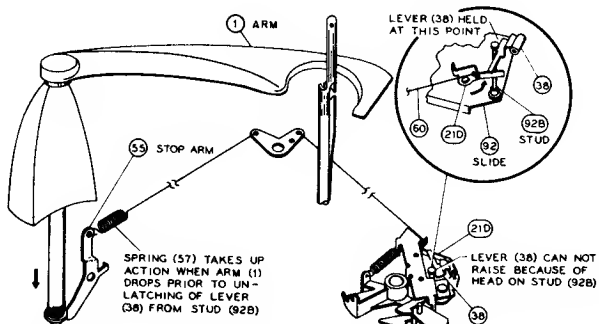

CYCLE OF OPERATION (Cont.)

**MECHANISM STOPS AUTOMATICALLY AFTER PLAYING LAST RECORD**

After the last record is played, the mechanism goes into the change cycle and as the cycling slide approaches its outermost position, the knobbed end of the stud (92B) slides underneath and fails to contact the escape lever (38) so the latch (21C) remains latched. The pickup arm return lever is locked in position and cannot direct the pickup arm inward.

The pickup arm will therefore remain in a position directly above the rest and when the elevating rod slides down the incline portion (92A) of the slide, the pickup arm sets on the rest but the turntable continues to rotate for an instant until the shut-off switch is actuated as described in the following paragraph.

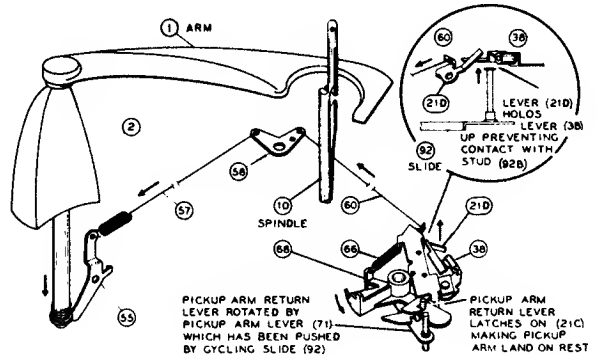

When the mechanism is going through a change cycle (stack of records supported on spindle) and the automatic stopping device has not been actuated, the pickup arm return lever rotates to push the pickup in for landing.

At this time the stud (68B) on the pickup return lever moves away from lever (74D) on the end of the switch link shut-off assembly and the tab (74A) on the other end of the assembly is pulled up by the tension of spring (73). While this tab (74A) is up and the cycling slide is returning to normal position, the escape lever (92D) passes under the tab and the power switch is not actuated.

However when the pickup arm return lever is latched the lever assembly (74C & D) is held in position so that the tab (74A) is down and the escape lever (92D) pushes against the tab as the cycling slide passes by. When these two points meet the motion is transferred to the control arm lever train and actuates the power switch (64) and the power is removed from the motor.

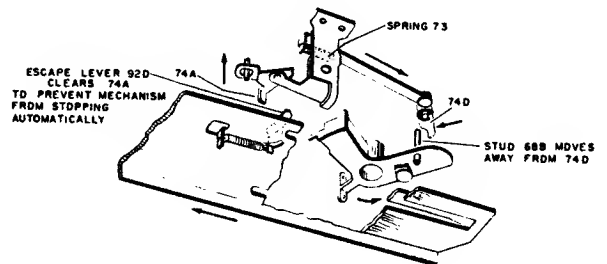

STUD (68B) ON PICKUP ARM RETURN LEVER HOLDS LEVER (74A) AGAINST TENSION OF SPRING (73)

LEVER (38) IS HELD UP BY LEVER (21D) PREVENTING UNLATCHING OF (21C)

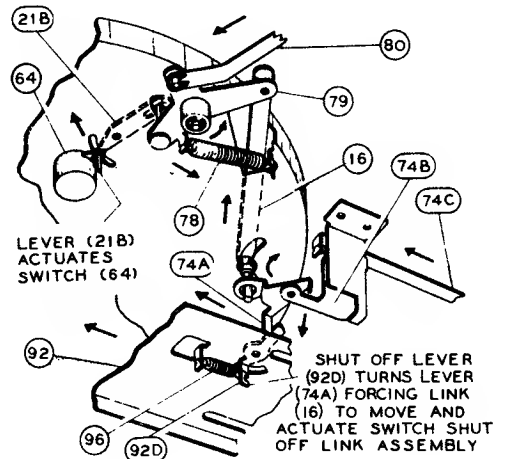
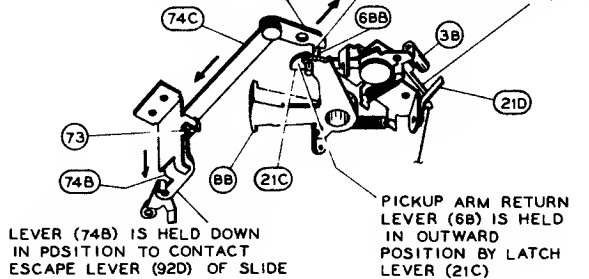

**LUBRICATION**

The mechanism is properly lubricated when it leaves the factory, additional lubrication should not be necessary for a long period of time.

A light machine oil (Singer sewing machine oil or equivalent) should be used to oil the bearings of the drive motor.

On all other bearing surfaces use \*STA-PUT No. 320 or equivalent lubricant sparingly.

Apply a medium weight clinging type of grease (\*STA-PUT

No. 512 or COSMOLUBE No. 1) to points of sliding contact including tabs of cycling gear.

It is important that the drive motor spindle, all rubber tires and the inside rim of the turntable be kept clean and free of oil and grease.

Carbon tetrachloride or naphtha is recommended for cleaning these parts.

\*STA-PUT and COSMOLUBE can be purchased from E. F. Houghton & Co., 303 W. Lehigh Ave., Philadelphia, Pa. and their distributors.

RCA Victor Record Changers RP-205 Series, Continued

SERVICE HINTS

REJECT CONTROL DOES NOT FUNCTION PROPERLY

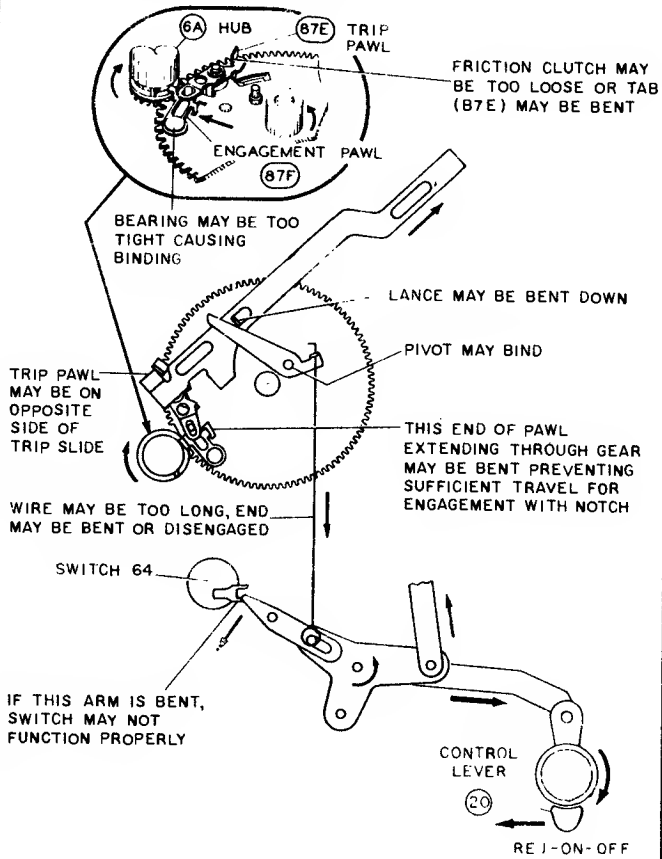

ERRATIC SPEED CHANGE

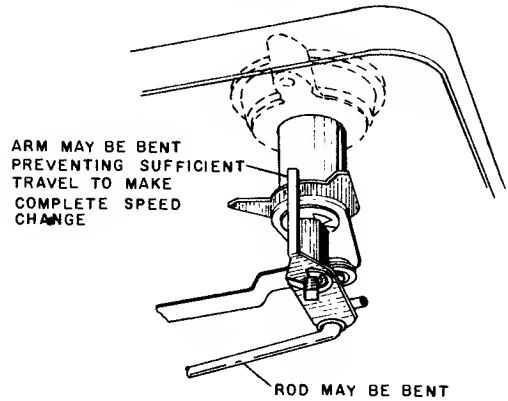

MECHANISM JAMS

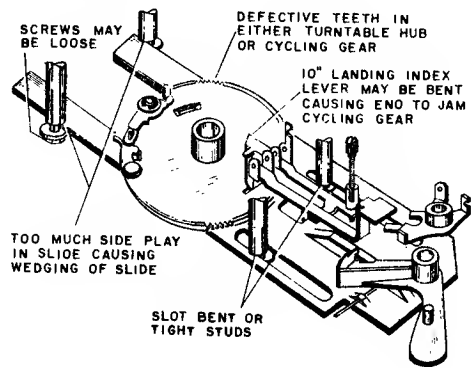

RECORDS FAIL TO SEPARATE PROPERLY

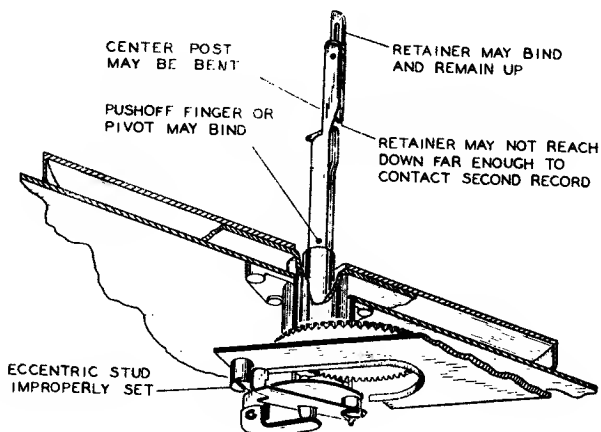

THERE MAY BE A BIND IN SHAFT OR SPRING (52) MAY BE WEAK OR MISSING

THERE MAY BE A BIND IN SHAFT OR SPRING (4B) MAY BE WEAK OR MISSING

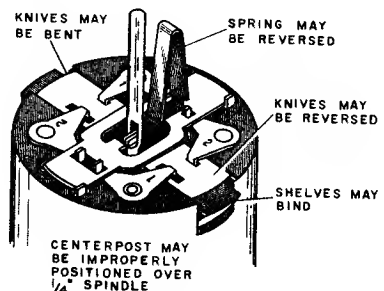

RCA Victor Record Changers RP-205 Series, Continued

SERVICE HINTS

CONTINUOUS TRIPPING

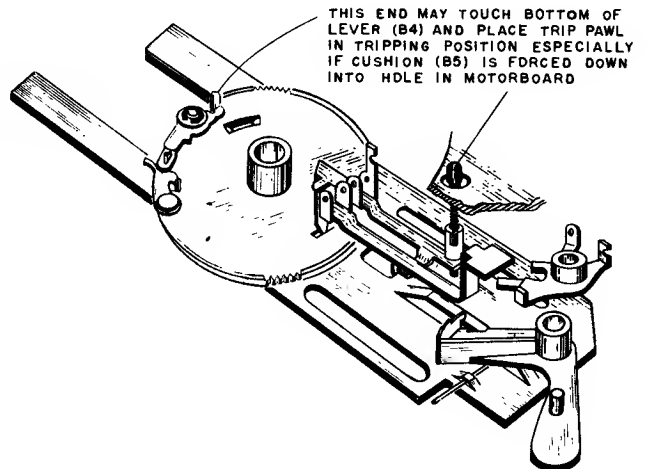
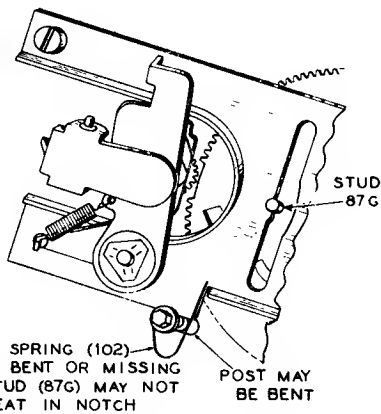
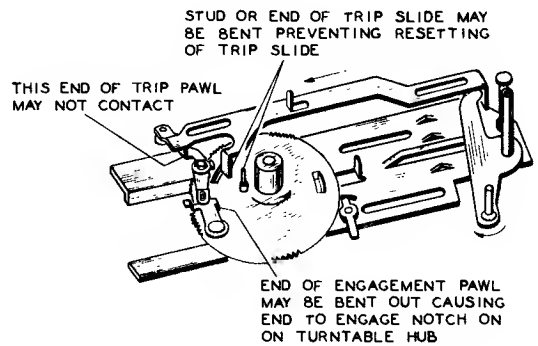
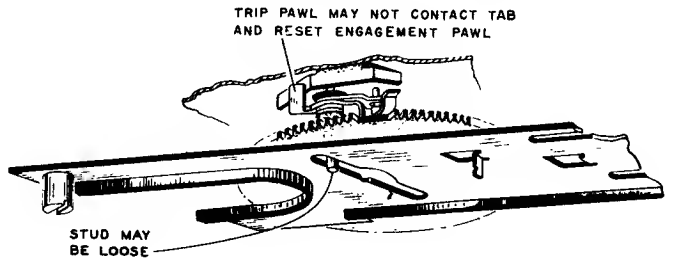
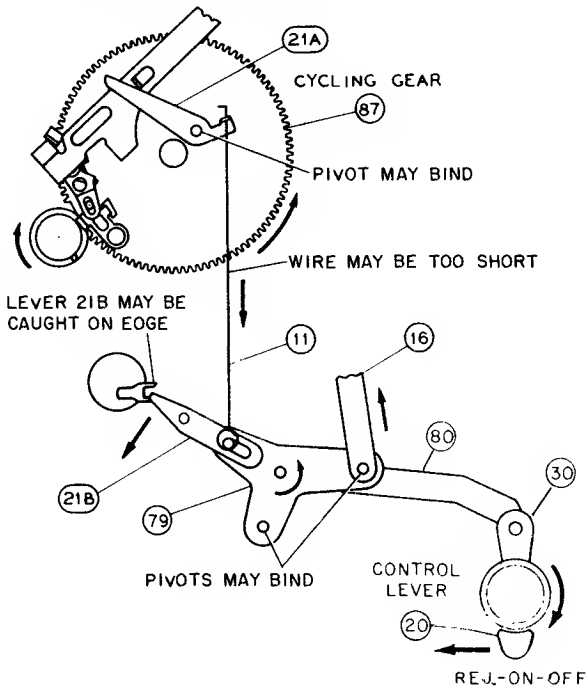

FAILS TO TRIP AUTOMATICALLY

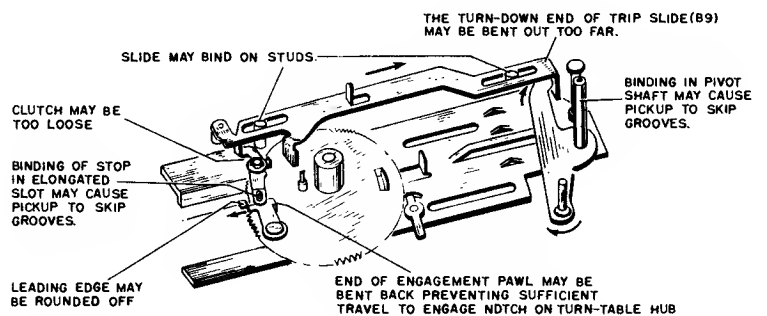
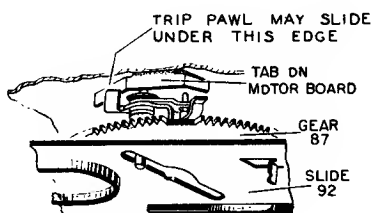



RCA Victor Record Changers RP-205 Series, Continued

SERVICE HINTS

PICKUP SETS ON REST AND MECHANISM STOPS WITHOUT PLAYING RECORDS

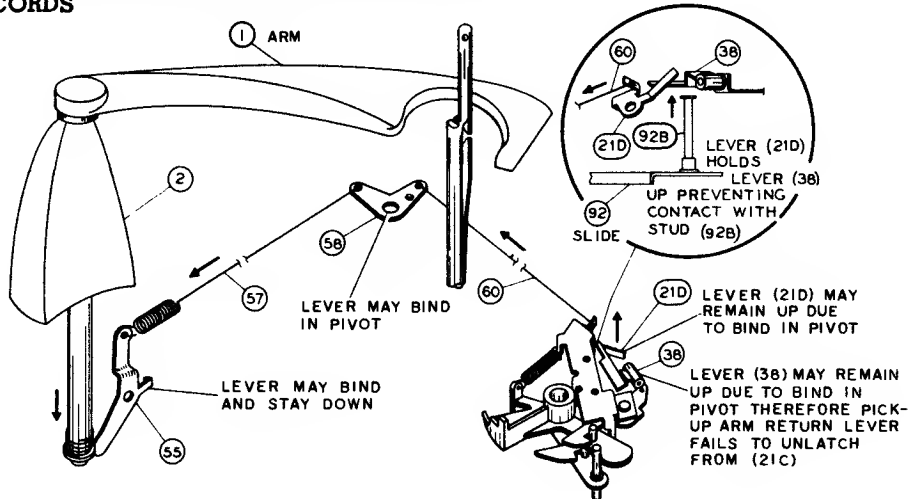

FAILURE TO STOP AUTOMATICALLY

NOTE: - IF PLAYING 7 IN. RECORDS ARM (1) MAY TOUCH THE LARGE DIAMETER CENTERPOST AND FAIL TO DROP AFTER THE LAST RECORD HAS DROPPED TO THE TURNTABLE

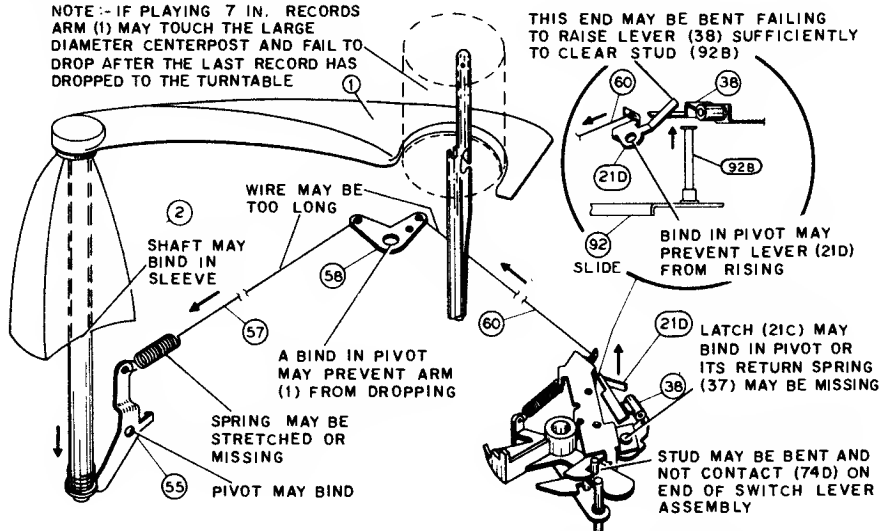

MOTOR FAILS TO SHUT OFF AFTER LAST RECORD HAS BEEN PLAYED

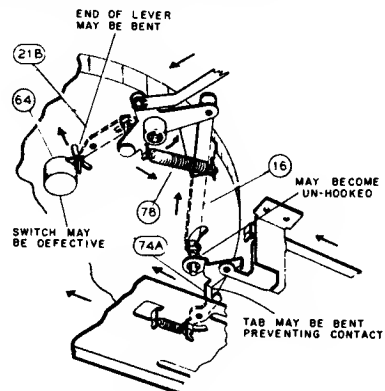
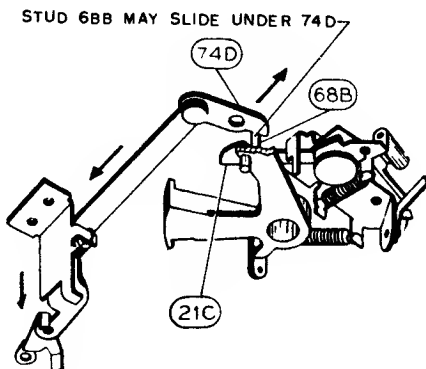

**SERVICE HINTS**

**PICKUP FAILS TO LAND PROPERLY ON 7"-10"-12" RECORDS**

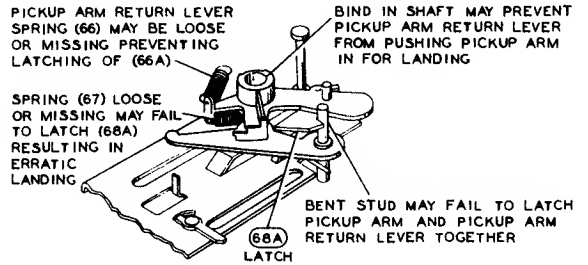
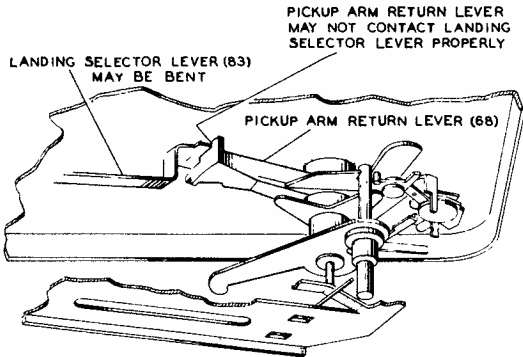

**PICKUP LANDS IN 12" POSITION WHEN PLAYING 10" RECORDS**

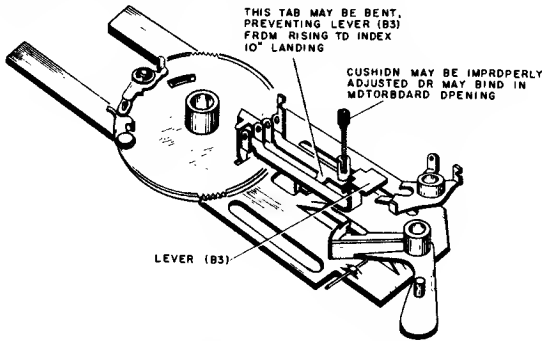

**"WOW" OR TURNTABLE SPEED VARIATION**

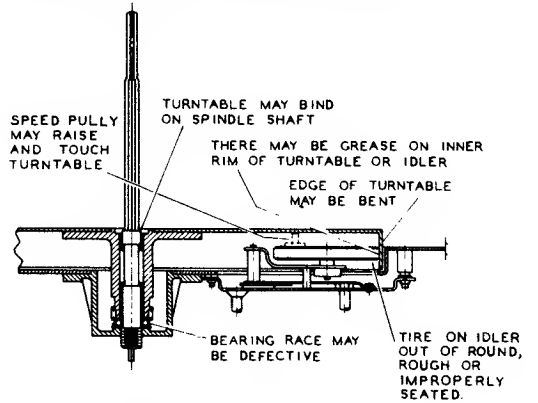

**PREMATURE TRIPPING**

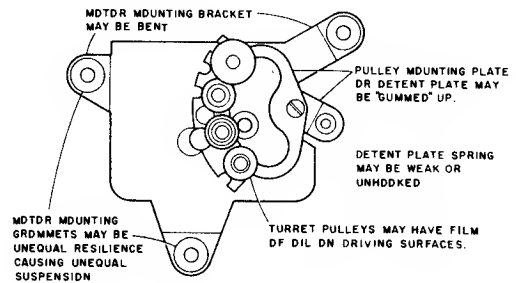
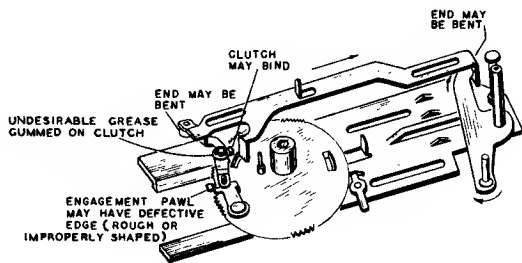

**PICKUP SKIPS GROOVES**

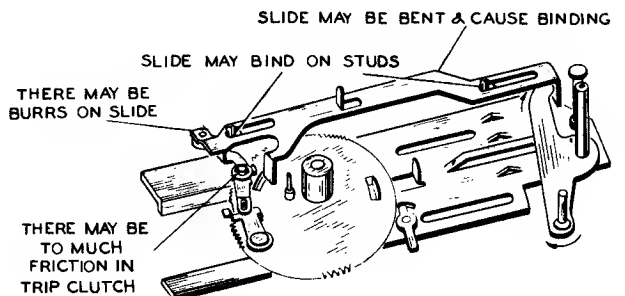
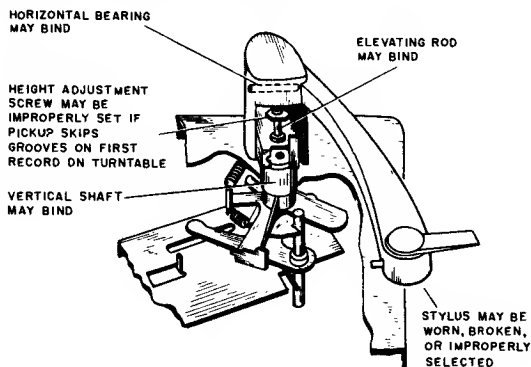

RCA Victor Record Changers RP-205 Series, Continued

CONTROLS

The record changer is provided with a dual control located in the right hand corner of the motor board and a stylus selector control located on the pickup arm.

The outer portion of the dual control provides a means of controlling the operation of the mechanism while the inner control governs the turntable speed.

By turning the outer control to the "ON" position, the turntable starts rotating. By turning the control one step further in a clockwise direction to the "REJ" position and permitting the knob to return to the "ON" position, the complete automatic operation of the mechanism is started.

The mechanism will stop automatically after the last record has been played but if desired, can be stopped by turning the control counter-clockwise to the "OFF" position and placing the pickup on the rest.

The inner or motor speed control makes possible the selection of one of four speeds, by rotating the knob to the proper position.

The speed control should be turned to the "N" position (midway between "45" and "78") to remove the force of the motor shaft against the idler wheel when the changer is not expected to be used for an extended period of time.

The stylus control for models using the ceramic pickup (#100653) has two positions. One position with the control lever to the right ("78" showing) selects the .003" stylus for

78 r.p.m. records, with the lever to the left ("MG" showing) the .001" stylus is selected for 16 $\frac{2}{3}$ , 33 $\frac{1}{3}$  and 45 r.p.m. records.

The stylus control for the variable reluctance pickup used with Model RP-205-3 has two positions (right and left). The arrow on the knob points to the stylus in use.

Two plug-in heads are supplied for use with Model RP-205-1. The head in use is secured to the pickup arm by a thumbscrew on the underside of the arm. One head is equipped with a .001" diamond stylus and is used for playing 16 $\frac{2}{3}$  r.p.m., 33 $\frac{1}{3}$  r.p.m. or 45 r.p.m. records. The other head is equipped with a .003" synthetic sapphire stylus and is used for playing 78 r.p.m. records only.

The removable centerpost is for use with 16 $\frac{2}{3}$  or 45 r.p.m. records having the large centerhole. It must be placed over the center spindle with the word "FRONT" FACING to the FRONT. Care should be exercised in placing and removing centerpost so as to prevent damage to smaller spindle.

A well is provided on the motorboard for storage of the centerpost when not in use. The centerpost may be firmly secured, after placing it in the well, by pushing down until a slight "click" is heard. It may be necessary to twist slightly while pushing down. To remove centerpost from well, twist slightly until centerpost "pops up".

To load or remove records, lift and turn the record stabilizer arm off to the side. After loading, the stabilizer arm should be turned to the center so it rests on the stack of records.

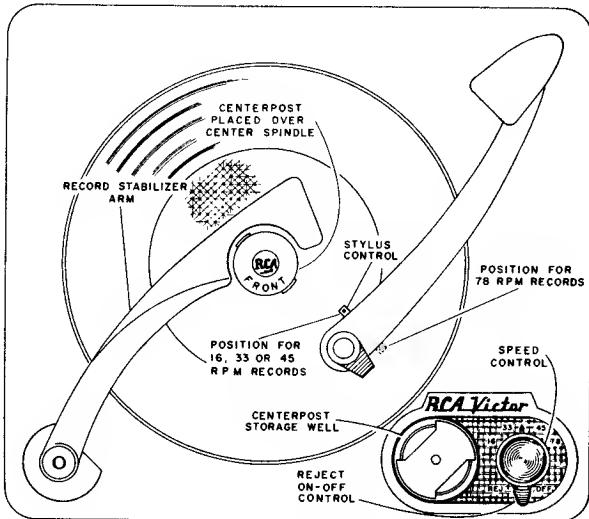

Figure 8—Controls (Ceramic Pickup)

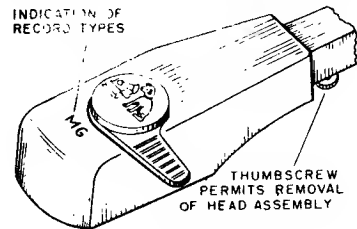

Figure 8A—Moving Coil Pickup

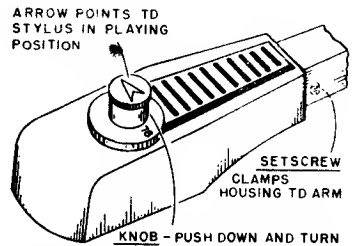

Figure 8B—Variable Reluctance Pickup

STYLUS REPLACEMENT

CERAMIC PICKUP #100653

The dual stylus used in this pickup is held in position by a spring clamp. To remove styli simply lift spring clamp and stylus will drop out. When inserting new stylus make certain the wire bridge holding the stylus assembly is engaging the drive arm to the cartridge element.

VARIABLE RELUCTANCE PICKUP MI-12110-A and MI-12112-A

The dual stylus assembly is held in position by a "C" ring retainer. Remove "C" ring, spring and washer; then push stylus through the cartridge.

The two styli mounted on the stylus assembly are of the "clip-in" type and may be individually replaced.

MOVING COIL PICKUPS #102955 and #102956

The styli used in these pickups are not designed for field replacement.

RCA Victor Record Changers RP-205 Series, Continued

REPLACEMENT PARTS

ILL. NO.	STOCK NO.	DESCRIPTION
		<b>16 2/3 / 45 R.P.M. CENTERPOST</b>
1	79096C	Centerpost—Centerpost assembly complete
1	100499	Cap—Nose cap—red—polystyrene
1	100500	Cap—Nose cap—black—polystyrene
1A	100501	Spring—Nose cap spring, 5/16" wide
2	100498	Spring—Slide return spring, 1 1/8" long, 1/4" wide
3	100494	Slide—Record separators actuator slide
4	100497	Sleeve—Actuating lever mounting sleeve
5 & 6	100495	Lever—Slide actuating pivot lever—L.H. & R.H. (1 set)
7	100493	Knife—Record separator knife (1 set)
8 & 9	100491A	Shelf—Record support shelves—L.H. & R.H. (1 set)
10	100492	Spring—Record support shelf spring
11	101566A	Body—Centerpost body assembly
12	100502	Screw—4.24 x 1 3/8" S.T.
13	100503	Washer—Flat metal washer 1" O.D., .814 I.D., .005" thick
14	101567	Rotor—rotor
15	100504	Spring—Rotor lift spring (coil) 2 3/4 turns
16	100505A	Lift—Rotor lift—black metal
17	100506	Retainer—Rotor lift retainer (12 teeth)

OPERATION OF  
16 2/3—45 R.P.M. CENTERPOST

In the out-of-cycle position (playing), the records with 1 1/2" centerhole rest upon the protruding shelves of the centerpost (knives are retracted).

When the mechanism goes through cycle, the record push-off finger in the 1/4" center spindle pushes against the actuator slide. This slide actuates two pairs of pivot levers. One pair of these levers pull the shelves inward (downward projections of pivot levers extend through long slots of knives and engage in short slots of the shelves). The other pair of levers push the separator knives outward (downward projections of pivot levers engage small holes in knives—long slot of shelves allow freedom of movement).

Two small coil springs push outward on the shelves and thus return them to the normal outward position. A formed metal spring extending up into the nose cap returns the slide to its normal position.

In the normal position the stack of records is supported by the shelves. During cycle the separator knives are extended first and then the shelves are retracted. The knives extend into the opening between the bottom record and the one adjacent; thus supporting all but the bottom record. When the shelves retract the bottom record falls to the turntable.

Careless placement or removal of the centerpost on the center spindle may result in bending of the center spindle. The centerpost should be placed on or removed from the center spindle with a STRAIGHT VERTICAL MOTION. The word "FRONT" should always face to the front of the record changer.

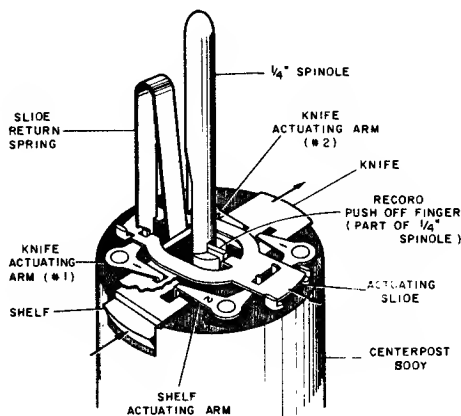

Figure 9—Centerpost Operation

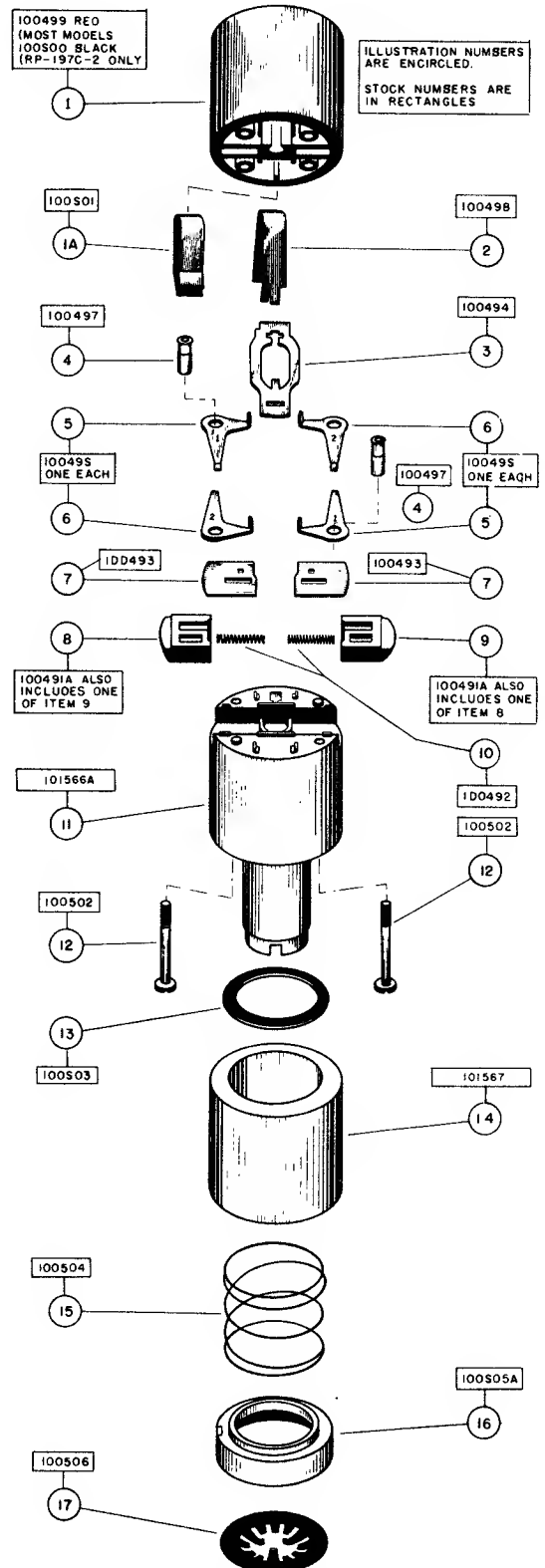

Figure 10—16 2/3—45 r.p.m. Centerpost

RCA Victor Record Changers RP-205 Series, Continued

REPLACEMENT PARTS

ILL. NO.	STOCK NO.	DESCRIPTION
		MOTOR ASSEMBLY Stamped: 936173-1 190 (115 v., 60 cycle) REFER TO FIG. 11
1	102934	Wheel—Idler wheel
2	75433	Washer—Thrust washer
3	102935	Retainer—Hairpin spring retainer for idler wheel
4	102936	Plate—Idler wheel support plate
5	78647	Washer—Flat metal washer for idler wheel support
6	78646	Retainer—Hairpin spring retainer for idler wheel support
7	78648	Link—Idler wheel support link
8	78764	Spacer—Idler support spacer
9	78374	Spring—Idler support spring
10		Screw—Turret pulley guide plate screw
11	102937	Guide—Guide for turret pulley mounting plate
12	102936	Spacer—Spacer for turret pulley mounting guide
13		Nut—Hex. head nut
14	76751	Grommet—Rubber grommet for motor mounting
15	76749	Spring—Spring pulley for motor shaft
16	76755	Spring—Detent spring
17	102940	Plate—Speed pulley mounting plate (less pulleys)
18	102943	Pulley—78 RPM pulley
19	102942	Pulley—45 RPM pulley
20	102941	Pulley—33 1/2 RPM pulley
21	102944	Pulley—16 RPM pulley
22	101584	Washer—Felt washer for turret pulleys
23	75427	Retainer—"C" type retaining ring for speed pulleys
24		Screw—For speed shift mounting plate
25		Washer—Lockwasher
26	102939	Lever—Speed shift lever
27	77134	Collar—Speed shift lever mounting collar (nut)
	102641	Motor—4 speed motor assembly complete—115 volts—60 cycles.

ILL. NO.	STOCK NO.	DESCRIPTION
		MOTOR ASSEMBLY Stamped: 936173-1 107 (115 v., 60 cycle) REFER TO FIG. 12
1	102968	Wheel—Idler wheel
2	78509	Washer—Fiber washer
3	78652	Washer—"C" type retaining washer
4	102969	Plate—Idler plate assembly
5	78517	Link—Idler link
6	78515	Washer—Metal washer
7	78512	Spring—Idler spring
8		Screw—Hold down plate mounting screw (#6-32)
9	102970	Plate—Hold down plate
10	78520	Spring—Shifter latch spring
11	78518	Arm—Pulley plate latch arm
12	78514	Grommet—Motor mounting grommet
13	78519	Spring—Pulley latch spring
14	78528	Washer—Speed pulley fiber washer
15	78525	Pulley—33 1/2 RPM pulley assembly
16	78526	Pulley—45 RPM pulley assembly
17	78527	Pulley—78 RPM pulley assembly
18	102972	Pulley—16 RPM pulley assembly
19	102974	Lever—Speed shift lever
20	78621	Lever—Latch arm lever
21	79967	Sleeve—Sleeve pulley for 60 cycle operation
22	78522	Sleeve—Sleeve pulley for 60 cycle operation
23	102973	Retainer—Pulley retainer ("C" ring)
	102971	Plate—Speed pulley mounting plate (less pulleys)
	102541	Motor—4 speed motor assembly complete—115 volts—60 cycles

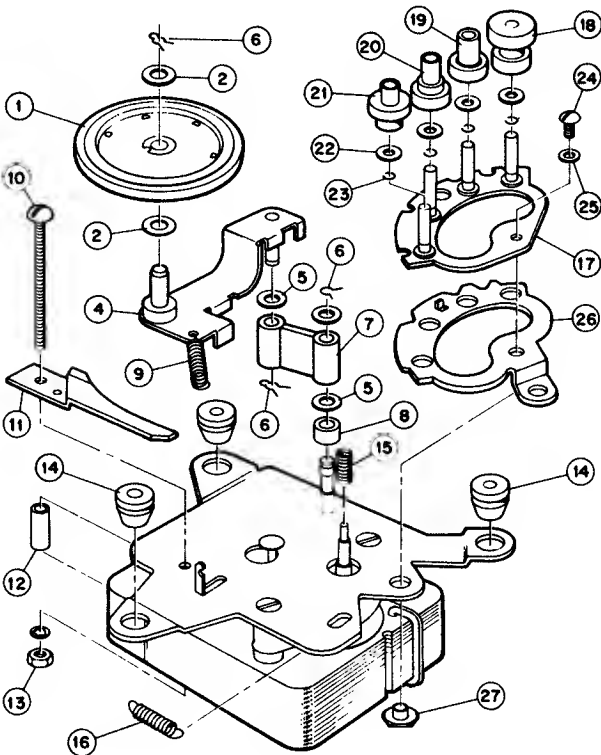

Figure 11—Motor Assembly Stamped 936173-1 190

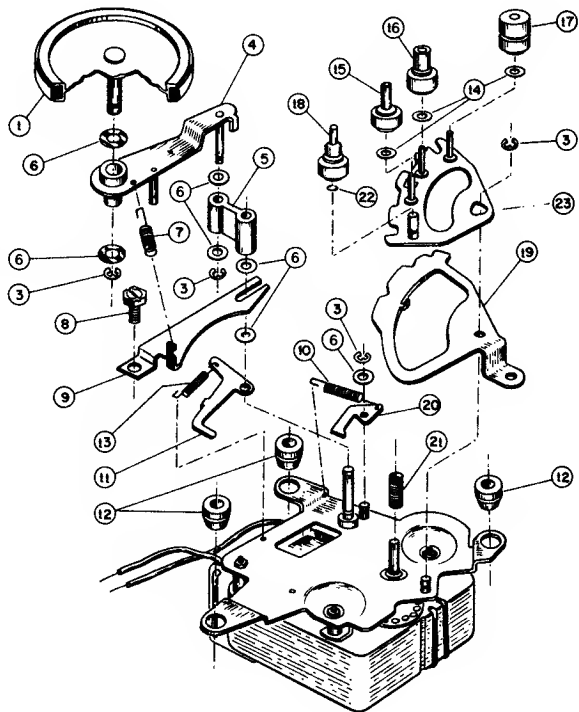

Figure 12—Motor Assembly Stamped 936173-1 107

RCA Victor Record Changers RP-205 Series, Continued

REPLACEMENT PARTS

ILL. NO.	STOCK NO.	DESCRIPTION
<b>MOTOR ASSEMBLY</b>		
Stamped: 971592-1 107 115/230 v. 60 cycle 972592-2 107 115/230 v. 50 cycle REFER TO FIGURE 12		
Same as listed for motor stamped 936173-1 107 except:		
17	100989	Spring—Spring sleeve for 50-cycle operation
17	100988	Spring—Spring sleeve for 60-cycle operation
	102900	Motor—115v./230v., 60-cycle motor complete
		Motor—115v./230v., 50-cycle motor
		Use 102900 Motor and 100989 Spring
<b>MOTOR ASSEMBLY</b>		
Stamped: 971584-1 115 volt, 60 cycle REFER TO FIGURE 13		
1	102934	Wheel—Idler wheel
2	75433	Washer—Flat metal washer for idler wheel mounting
3	102935	Retainer—Hairpin spring retainer for idler wheel
4	102936	Plate—Idler wheel support plate
5	78374	Spring—Idler wheel tension spring
6	78648	Link—Idler wheel support link
7	78647	Washer—Flat metal washer for idler support
8	78646	Retainer—Hairpin spring retainer for idler wheel mounting plate & support
9	78764	Spacer—Idler support spacer
10	102937	Guide—Guide for turret pulley mounting plate
11	.....	Screw—Turret pulley mounting plate screw
12	.....	Washer—Lockwasher
13	102943	Pulley—78 RPM turret pulley
14	102942	Pulley—45 RPM turret pulley
15	102941	Pulley—33½ RPM turret pulley
16	102957	Pulley—16½ RPM turret pulley
17	101564	Washer—Felt washer for turret pulleys
18	75427	Retainer—Pulley retainer ("C" ring) for turret pulleys
19	.....	Screw—Round head screw for pulley mounting plate
20	102940	Plate—Turret pulley mounting plate
21	102958	Lever—Speed shift lever
22	102960	Sleeve—Sleeve pulley for motor shaft (16½ r.p.m. operation)
23	102959	Pulley—Motor shaft pulley—less set screw
24	78767	Screw—Set screw for motor shaft pulley
25	.....	Screw—Flat head screw for motor mounting plate
26	.....	Screw—Round head machine screw for motor mounting plate
27	76751	Grommet—Rubber grommet for motor mounting plate
28	.....	Washer—Lockwasher for motor mounting plate
29	77134	Collar—Speed shift lever collar (nut)
30	76755	Spring—Detent spring
31	102961	Plate—Motor mounting plate only
	102919	Motor—Motor assembly complete—115 volt, 60 cycle—4 pole, 4 speed
		115 volt, 50 cycle conversion parts
22	103026	Sleeve—Sleeve pulley for motor shaft (16½ r.p.m. operation)—replaces #102960
23	103027	Pulley—Motor shaft pulley—less setscrew—replaces #102959
	79249	Resistor—Flexible wire-wound resistor, 60 ohms, ±10%, 5 watt (used in series with motor winding)

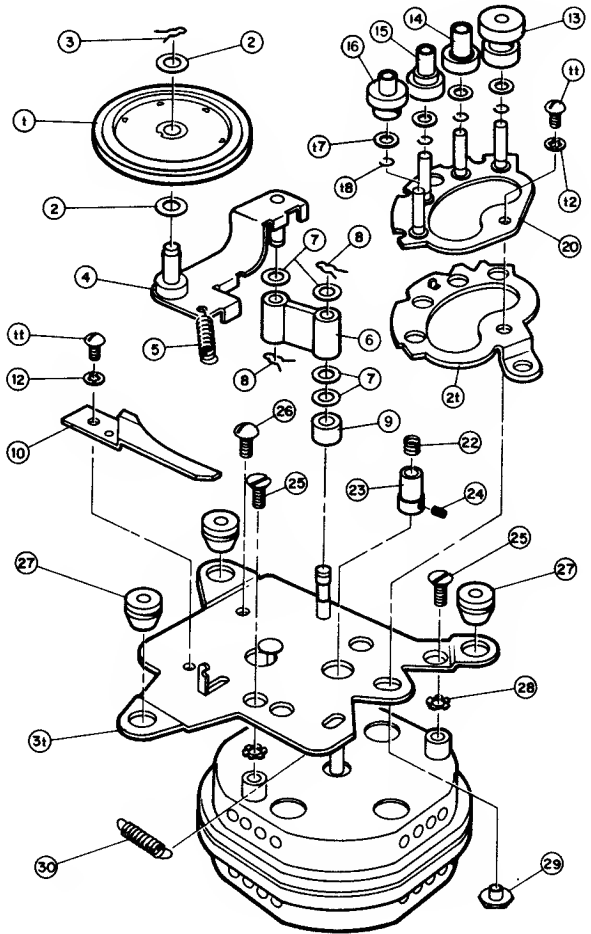

Figure 13—Four-Pole Motor Assembly (Stamped 971584-1)

REPLACEMENT PARTS

ILL. NO.	STOCK NO.	DESCRIPTION
1	102524	Arm—Stabilizer arm assembly—complete with shaft, pin and gold finish cap—antique white—for all models except RP-205-1
1	102931	Arm—Stabilizer arm assembly complete with shaft, pin and gold finish cap—satin brass—for RP-205-1
1A	102525	Cap—Aluminum cap—polished gold finish—for stabilizer arm
1B	100994	Ring—"O" type rubber cushion ring for stabilizer arm.
2	102540	Support—Stabilizer arm support—satin gold finish—for all models except RP-205-1
2	102928	Support—Stabilizer arm support—lustrous aluminum finish—for RP-205-1
3	78708	Spring—Return spring for stabilizer arm.
4	.....	Washer—Flat washer for stabilizer arm shaft. (5/16" O.D. x .188" I.D. x .0825")
5	33726	Washer—"C" type retaining washer. (.406" O.D. x .125" I.D.)
6	102535	Turntable—Metal turntable—antique white enamel—less support and mat—for RP-205-2, RP-205A-1, RP-205A-2
6	102927	Turntable—Metal turntable—charcoal grey—with rubber mat, brass center disc and turntable support—for RP-205-1 and RP-205-3
6	102963	Turntable—Metal turntable—charcoal grey with rubber mat, brass center disc and turntable support—for RP-205-4

6A	102536	Support—Turntable support and pinion complete with brass bearing for turntable Stock No. 102535
6B	.....	Nut—#8-32 hex nut for mounting turntable support
6C	102537	Mat—Rubber mat for turntable Stock No. 102535
7	78654	Ring—Retaining ring for turntable assembly
8	78720	Washer—Felt washer for turntable thrust bearing #78660 (2 req'd)
9	78660	Bearing—Thrust bearing for turntable
10	79242A	Spindle—Spindle assembly
11	102533	Wire—Reject operating wire
12	74337	Nut—Speed nut for switch & reject lever assembly Ill. #79
13	78659	Pin—Bearing pin for landing selector levers Ill. #88 & #64
14	78747	Spring—Coil spring for motorboard assembly (.200" O.D., .531" free length, 13 turns)
15	78709	Spring—Return spring for landing selector lever
16	102530	Link—Reject link with studs
17	78649	Washer—Flat washer for pickup arm pivot shaft
18	35969	Washer—"C" type retaining washer for pickup arm lever Ill. #71. (.500" O.D., .183" I.D.)
19	102528	Knob—Speed control knob and shaft assembly
20	102527	Lever—"On-Off Rej." control lever and shaft assembly
21	102539	Motorboard—Motorboard assembly complete with stabilizer support, arm rest, cable clamps, and all welded and/or staked parts—satin gold finish—for all models except RP-205-1

RCA Victor Record Changers RP-205 Series, Continued

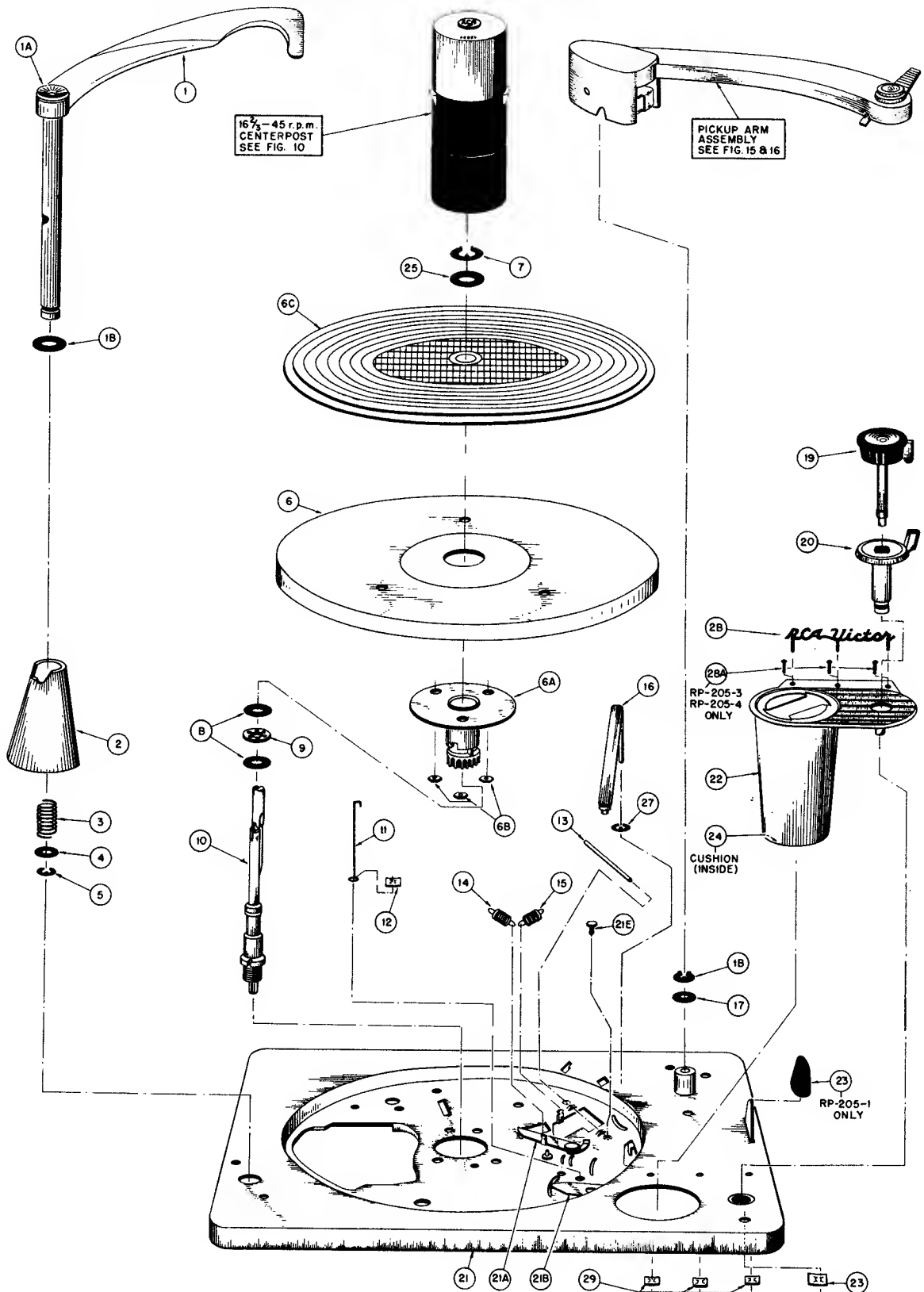

Figure 14A—Exploded View Showing Mechanism Parts Above Motor Board

VOLUME R-17, MOST-OFTEN-NEEDED 1957 RADIO SERVICING INFORMATION

RCA Victor Record Changers RP-205 Series, Continued

REPLACEMENT PARTS

ILL. NO.	STOCK NO.	DESCRIPTION
21	102924	Motorboard-Motorboard assembly complete with stabilizer support, arm rest, cable clamps, and all welded end/or staked parts-lustrous aluminum finish-for RP-205-1
21A	.....	Lever-(pt. of Motorboard)
21B	102544	Lever-Switch actuating lever with mounting stud (Pt. of Motorboard)
21C	78669	Lever-Pickup arm latch lever assembly (Part of Motorboard)
21D	.....	Screw-H.H.S.T. #4 x 1/4"
21E	.....	Screw-S.T.F.T. hd. #8 x 3/4" (Pt. of Motorboard)
21F	.....	.....
22	102526	Escutcheon-Polystyrene control escutcheon & centerpost well-antique white with gold markings-for all models except RP-205-1
22	102929	Escutcheon-Polystyrene control escutcheon and centerpost well-metalized gold & charcoal grey with gold markings-for RP-205-1
23	74340	Nut-Speednut, retainer for control escutcheon
24	102536	Cushion-Foam rubber pad-antique white-for centerpost well
25	103164	Washer-Black neoprene washer
26	101199	Bumper-Rubber insulating bumper for pickup arm rest-for RP-205-1
27	33726	Washer-"C" type retaining washer (2 req'd) for link Ill. #16
28	77033	Nameplate-"RCA Victor" nameplate-gold finish.-for RP-205-2, RP-205A-1 and RP-205A-2
28	102925	Nameplate-"RCA Victor" nameplate-charcoal gray-for RP-205-1
28A	102962	Pin-Retaining pin for escutcheon-brass-for RP-205-3 and RP-205-4 (3 req'd)
29	77013	Nut-Speednut, retainer for nameplate or for retaining pins (3 req'd)
30	78688	Lever-Reject lever arm assembly complete with stud
31	76221	Washer-"C" type retaining washer for control lever Ill. #20
32	33726	Washer-"C" type retaining washer (.406" O.D. x .125" I.D.)
33	102926	Rod-Motor speed selector rod for RP-205-1, RP-205-3 and RP-205-4
33	102534	Rod-Motor speed selector rod for RP-205-2, RP-205A-1 and RP-205A-2
34	33139	Grommet-Rubber grommet for motor speed shift lever
35	102531	Lever-Motor speed shift lever
36	35969	Washer-"C" type retaining washer for knob shaft (.500" O.D. x .183" I.D.)
37	78688	Spring-Return spring for pickup arm latch (.200" O.D. x 718" free length)
36	78658	Lever-Actuating lever for pickup arm latch
39	78651	Washer-"C" type retaining washer
40	78712	Spring-Index lever return spring
41	100723	Lever-Index lever assembly-chrome plated-12" records landing selection
42	.....	Nut-#6-32 Nut for mtg. index lever Ill. #41 (2 req'd)
43	78656	Bracket-Spindle mtg. bracket assembly complete with stud
44	100342	Nut-1/2"-32 retaining nut for spindle Ill. #10
45	78670	Arm-Spindle operating arm assembly
46	79092	Washer-Flat metal washer for spindle mtg. bracket Ill. #43 (3/16" O.D. x .158" I.D.)
47	33726	Washer-"C" type retaining washer (.406" O.D. x .125" I.D.)
46	78711	Spring-Return spring for spindle operating arm
49	78657	Lever-Spindle reset lever
50	78694	Pin-Pivot pin for spindle reset lever
51	78661	Washer-"C" type retaining ring for pivot pin Ill. #50 (2 req'd)
52	78745	Spring-Actuating spring for reset lever
53	33726	Washer-"C" type retaining washer (.406" O.D. x .125" I.D.) (3 req'd)
53A	75749	Washer-Flat washer for motor mounting (3 req'd)
54	33136	Grommet-Rubber grommet for motor speed selector rod
55	78674	Lever-Shut-off lever assembly
86	.....	Screw-#8 x 3/8" hex head S.T. screw for shut-off lever assembly Ill. #55
57	78681	Spring-Shut-off lever spring
58	78675	Arm-Transfer arm for shut-off mechanism
59	78714	Spring-Return spring for transfer arm
80	78679	Wire-Shut-off wire
61	35969	Washer-"C" type retaining washer for transfer arm Ill. #58 (.500" O.D. x .183" I.D.)
62	78676	Switch-Muting switch assembly
63	.....	Screw-H.H.S.T. #8 x 3/8" screw for muting switch
64	76301	Switch-"On-Off" switch-SFST.
65	78661	Lever-Landing selector lever
86	78713	Spring-Return spring for pickup arm return lever
67	78699	Spring-Return spring for pickup arm return lever actuating lever
68	78655	Lever-Pickup arm return lever assembly
89	78724	Lever-Actuating lever assembly for pickup arm return
70	78653	Ring-Retaining ring for pickup arm return actuating lever Ill. #69

ILL. NO.	STOCK NO.	DESCRIPTION
71	79091	Lever-Pickup arm lever
72	78672	Rod-Pickup arm lift rod
73	78699	Spring-Return spring for switch shut-off link
74	78695	Link-Switch shut-off link assembly
75	78651	Washer-"C" type retaining washer for switch shut-off link bracket Ill. #76
76	78664	Bracket-Switch shut-off link bracket
77	.....	Nut-#6-32 nut for mtg. switch shut-off link bracket Ill. #76 (2 req'd)
78	78710	Spring-Return spring for switch and reject lever
79	102529	Lever-Reject & switch control pivot lever with studs
80	102532	Link-Control link for "On-Off-Rej."
81	100157	Washer-Flat washer for mounting trip slide lever Ill. #89
82	35969	Washer-"C" type retaining washer for reject control pivot lever Ill. #79
83	78689	Lever-Landing selector lever
84	78690	Lever-Index lever for 10" records-with adjustable cushion
86	100913	Cushion-Rubber cushion & screw assembly for index lever (Ill. #84)
86	78721	Washer-Flat washer for landing control bearing pin Ill. #13 (3 req'd)
87	78691	Gear-Cycling gear-less pawl levers
87A	78651	Washer-"C" type retaining washer
87B	79240	Washer-Flat washer for trip pawl pressure spring
87C	78727	Spring-Trip pawl pressure spring
87D	78725	Lever-Trip pawl actuating lever
87E	78726	Lever-Trip pawl intermediate lever
86	35969	Washer-"C" type retaining washer for spindle mounting bracket Ill. #43 (.500" O.D. x .183" I.D.)
89	78688	Lever-Trip slide lever
90	78719	Washer-Flat washer for mounting trip slide lever Ill. #89
91	33726	Washer-"C" type retaining washer for trip slide lever Ill. #89 (2 req'd) (.406" O.D. x .125" I.D.)
92	79794	Slide-Cycling slide assembly
93	.....	Wire-Steel wire for slide (.059" dia. x 2 1/4")
94	75749	Washer-Flat washer for slide assembly (79794) (2 req'd)
95	33726	Washer-"C" type retaining washer (.406" O.D. x .125" I.D.) (2 req'd)
96	78705	Spring-Actuating spring for escape shut-off lever (Part of Ill. #92)
97	.....	Washer-#6 flat washer (3 req'd) for slide mounting
98	.....	Lockwasher-Ext. #6 for slide mounting (7 req'd)
99	.....	Screw-H.H. #6-32 x 3/16" screw for slide mounting (2 req'd)
100	74431	Washer-Spring retaining washer for eccentric stud (Part of Ill. #92)
101	78685	Stud-Eccentric stud for drop adjustment (Part of Ill. #92)
102	79352	Spring-Formed wire spring for slide assembly
103	100735	Support-Spindle bearing support
104	.....	Screw-#6-32 x 5/16" screw for mounting support Ill. #103
105	78653	Ring-Retaining ring for landing selecting lever Ill. #65
106	77586	Washer-"C" type retaining washer for link Ill. #74
107	100987	Spring-Tension spring for pickup arm latch actuating lever Ill. #36
108	100986	Plate-Spacer plate under switch shut-off link bracket Ill. #76
<b>MISCELLANEOUS</b>		
74545	.....	Cable-Shielded audio cable (66 in.) with pin plug-for RP-205-3 and RP-205-4
73805	.....	Capacitor-Fixed, paper, .0047 mf, ±20%, 1000 v.-for RP-205A-1 and RP-205A-2
79149	.....	Capacitor-Fixed, paper 0.1 mf, ±20%, 600 v. (part of click filter)-for RP-205-1, RP-205-3 and RP-205-4
100211	.....	Connector-Closed end connector (small) for power leads
101825	.....	Connector-Closed end connector (large) for power leads
30868	.....	Connector-2-Contact female connector for power leads-for Models 7-HF-4Q and 7-HF-5Q
30870	.....	Connector-2-Contact male connector for power leads-for Models 7-HF-2 and 7-HF-3
100510	.....	Connector-4-Contact male connector for power leads-for Models 7-HF-4 and 7-HF-5
70392	.....	Cord-Power cord (6 ft.) with standard two prong plug-for RP-205-3 and RP-205-4
31048	.....	Plug-Single-pin plug for audio cable
74192	.....	Plug-3-prong plug for audio cable
502068	.....	Resistor-Fixed, composition, 86 ohm, ±10%, 1/2 watt (part of click filter)-for RP-205-1, RP-205-3 and RP-205-4
32827	.....	Switch-Voltage selection switch (117 v./234 v.)-for RP-205A-1 and RP-205A-2
101741	.....	Clip-Pickup arm retaining clip-for RP-205-6 only
<b>MOUNTING HARDWARE</b> (as supplied with RP-205-3 and RP-205-4)		
76894	.....	Nut-Spring nut
78840	.....	Spring-Conical spring
79094	.....	Stud-Mounting stud
78642	.....	Washer-Fiber washer



RCA Victor Record Changers RP-205 Series, Continued

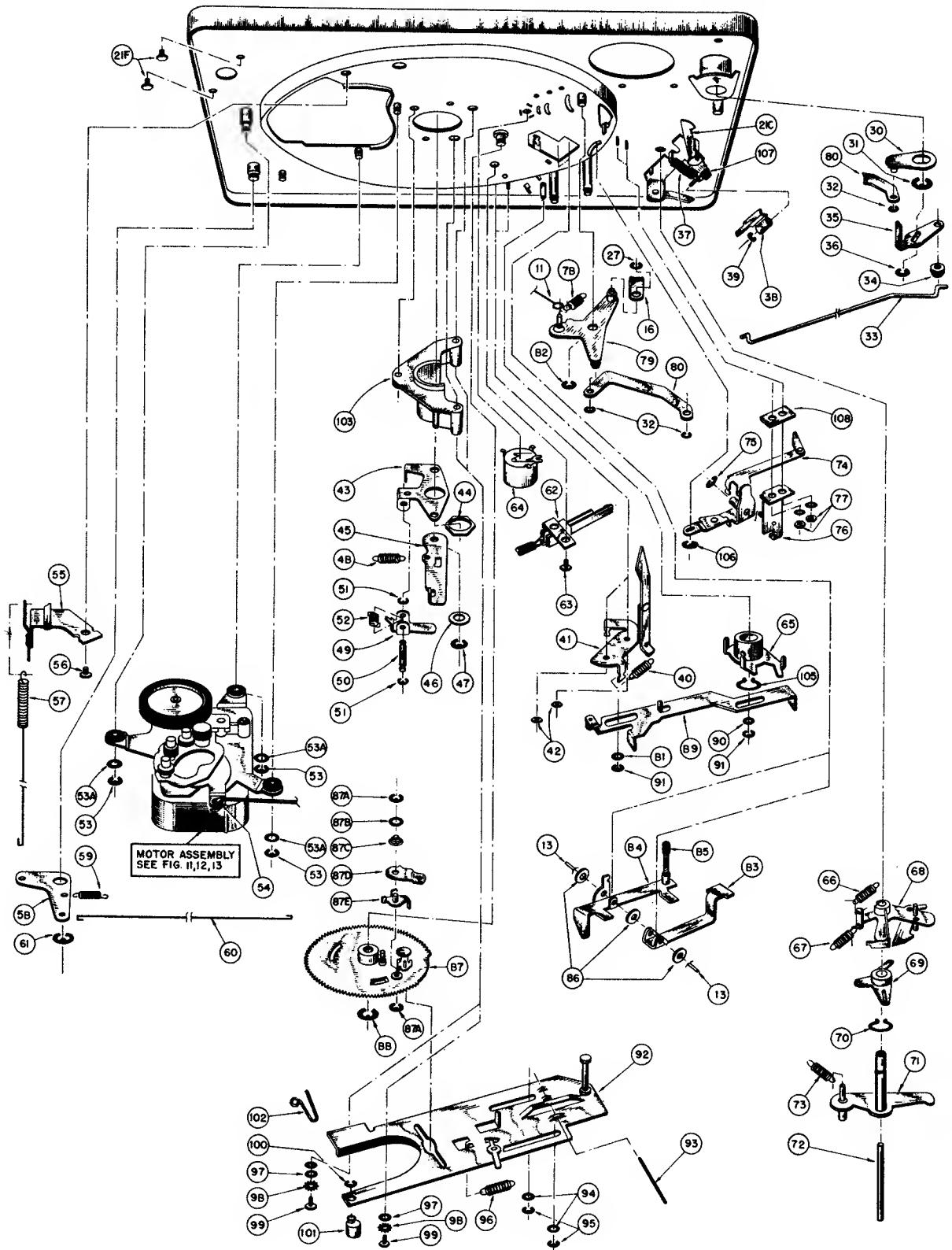

Figure 14B—Exploded View Showing Parts Below Motor Board

RCA Victor Record Changers RP-205 Series, Continued

REPLACEMENT PARTS

ILL. NO.	STOCK NO.	DESCRIPTION	ILL. NO.	STOCK NO.	DESCRIPTION
		<b>PICKUP &amp; ARM ASSEMBLIES</b> For: RP-205-2 RP-205-6 RP-205A-1 RP-205A-2	7	79449	Cable-Pickup shielded cable complete with terminals
1	102473	Arm-Pickup arm shell only, with counterbalance spring retainer-aluminum-antique white	8	74337	Nut-Speed nut to hold cable (2 req'd)
3	102542	Emblem-Trademark emblem-black over polished brass-for RP-205-2	9	102474	Pivot-Bearing for pivot shaft
3	102902	Monogram-"RCA" trademark monogram-for RP-205A-1 and RP-205A-2	10	102475	Shaft-Pivot shaft
4	102543	Lift-Pickup arm lift, aluminum-polished gold finish	11	78736	Spring-Spring for height adjustment screw (6 turns)
5	100653	Pickup-Ceramic pickup with dual stylus	12	78740	Screw-Hex. hd. #6-32 height adjustment screw
5A	78827	Stylus-Dual stylus assembly with two synthetic sapphire styli	13	101265	Spring-Counterbalance spring
6	74410	Screw-Pickup mounting screw-#4-40 fillister head	14	102472	Bracket-Mounting bracket for pickup arm
			15	100999	Spring-Landing adjustment screw spring (4 turns)
			16	78732	Collar-Pickup arm mounting collar-less screw
			17	79245	Screw-#10-32 set screw for pickup arm collar
			18	101270	Nut-Split nut for pickup arm landing adjustment
			19	—	Washer-Flat metal washer, bearing for landing adjustment nut (2 req'd)
				101741	Chip-Pickup arm retaining chip-for RP-205-6 only

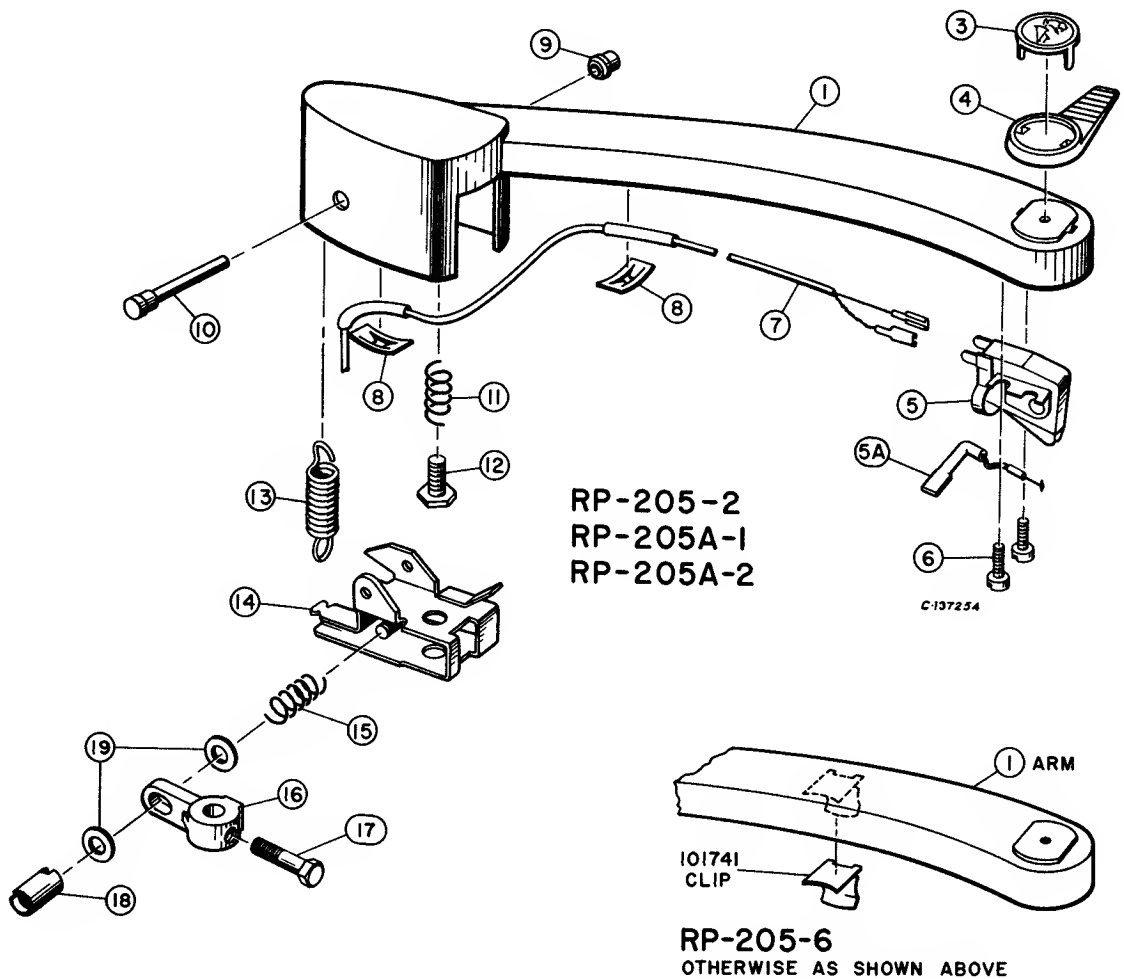

Figure 15-Pickup & Arm Assembly for RP-205-2, RP-205-6, RP-205A-1 and RP-205A-2

RCA Victor Record Changers RP-205 Series, Continued

REPLACEMENT PARTS

ILL. NO.	STOCK NO.	DESCRIPTION	ILL. NO.	STOCK NO.	DESCRIPTION
<b>PICKUP &amp; ARM ASSEMBLIES</b> For: RP-205-1 RP-205-3 (MI-12807-A) RP-205-4 (MI-12820-B)					
1	102930	Arm—Pickup arm shell only—less detachable pickup housing—with counterbalance spring retainer—charcoal gray—for RP-205-1	3	100653	Pickup—Ceramic pickup with dual synthetic sapphire stylus—for RP-205-4
1	102966	Arm—Pickup arm shell only—less detachable pickup housing—with counterbalance spring retainer—charcoal gray—for RP-205-3	3A	MI-12111-A	Stylus—Stylus assembly for MI-12110-A pickup—complete with 1-mil diamond and 3-mil synthetic sapphire clip-in stylii
1	102964	Arm—Pickup arm shell only—less detachable pickup housing—with counterbalance spring retainer—antique white—for RP-205-4	3A	MI-12113-A	Stylus—Stylus assembly for MI-12112-A pickup—complete with 1-mil and 3-mil synthetic sapphire clip-in stylii
1A	100747	Screw—#6-32 pickup head retaining thumbscrew—for RP-205-1	3AA	101672	Stylus—“Clip in” 3-mil synthetic sapphire stylus for MI-12110-A & MI-12112-A pickups
1A	78767	Screw—#6-32 x 1/8" lg. pickup head retaining setscrew—for RP-205-3 and RP-205-4	3AB	211951	Stylus—“Clip-in” 1-mil diamond stylus for MI-12110-A pickup
1B	101271	Connector—2 contact female connector—pickup arm to pickup head—for RP-205-1	3AB	101671	Stylus—“Clip-in” 1-mil synthetic sapphire stylus—for MI-12112-A pickup
2	102920	Housing—Pickup head housing—charcoal gray—with lift (less pickup & emblem)—for RP-205-1	3A'	78827	Stylus—Duel synthetic sapphire stylus—for RP-205-4
2	102967	Housing—Pickup head housing—charcoal gray—for RP-205-3	4	78772	Spring—Tension spring for mounting of MI-12111-A and MI-12113-A stylus assemblies
2	102965	Housing—Pickup head housing—antique white—for RP-205-4	5	78773	Washer—Flat metal washer for mounting of MI-12111-A and MI-12113-A stylus assemblies
2A	102542	Emblem—Trademark emblem—for RP-205-1	6	78774	Washer—“C” washer for mounting of MI-12111-A and MI-12113-A stylus assemblies
2A	100923	Monogram—Trademark monogram—for RP-205-4	7	100581	Screw—#4-40 x 5/16" fil. hd. pickup mounting screw (2 req'd)—for RP-205-1
2B	103029	Escutcheon—Stylus indicator escutcheon—for RP-205-3	7	100745	Screw—#4-40 x 1/4" fil. hd. pickup mounting screw (2 req'd)—for RP-205-3
2C	100563	Cover—Ornamental cover for pickup head—for RP-205-3	7	74410	Screw—#4-40 x 3/16" fil. hd. pickup mounting screw (2 req'd)—for RP-205-4
2D	100564	Connector—2-contact male connector for pickup (less wire & terminals)—for RP-205-1	8	100742	Cable—Pickup shielded cable complete with ground terminal—for RP-205-1
2E	100562	Ring—Connector retaining ring—for RP-205-1	8	100741	Cable—Pickup shielded cable with terminals for RP-205-3
2F	103028	Decalcomania—“MG” decalcomania—for RP-208-1	8	79449	Cable—Pickup shielded cable with terminals for RP-205-4
2F	100912	Decalcomania—“78” RPM decalcomania—for RP-205-1	9	100748	Knob—Stylus selector knob—for RP-205-3
2G	101786	Plate—Counterbalance plate for 3-mil pickup head—for RP-205-1	10	74337	Nut—Speednut, retainer for pickup cable (2 req'd)
3	102958	Pickup—Pickup for “45” “33” “16” with 1-mil diamond stylus—for RP-205-1	11	78741	Pivot—Bress pivot bearing
3	102955	Pickup—Pickup for “78” with 3-mil synthetic sapphire stylus—for RP-205-1	12	78742	Shaft—Pivot shaft
3	MI-12110-A	Pickup—Reluctance pickup complete with 1-mil diamond & 3-mil synthetic sapphire stylii, mounting screws & knob—for RP-205-3	13	78738	Spring—Spring for height adjustment screw
3	MI-12112-A	Pickup—Reluctance pickup complete with 1-mil & 3-mil synthetic sapphire stylii, mounting screws & knob—for RP-205-3	14	78740	Spring—Hex. hd. #6-32 height adjustment screw
			15	100758	Spring—Counterbalance spring—for RP-205-1
			15	101265	Spring—Counterbalance spring—for RP-205-3
			16	78734	Spring—Counterbalance spring—for RP-205-4
			17	100999	Bracket—Mtg. bracket assembly for pickup arm
			18	78732	Spring—Landing adjustment screw spring
			18A	79245	Collar—Pickup arm mtg. collar—less screw
			19	101270	Nut—Split nut for pickup arm landing adjustment
			20		Washer—Flat metal washer—bearing for split nut landing adjustment (2 req'd)

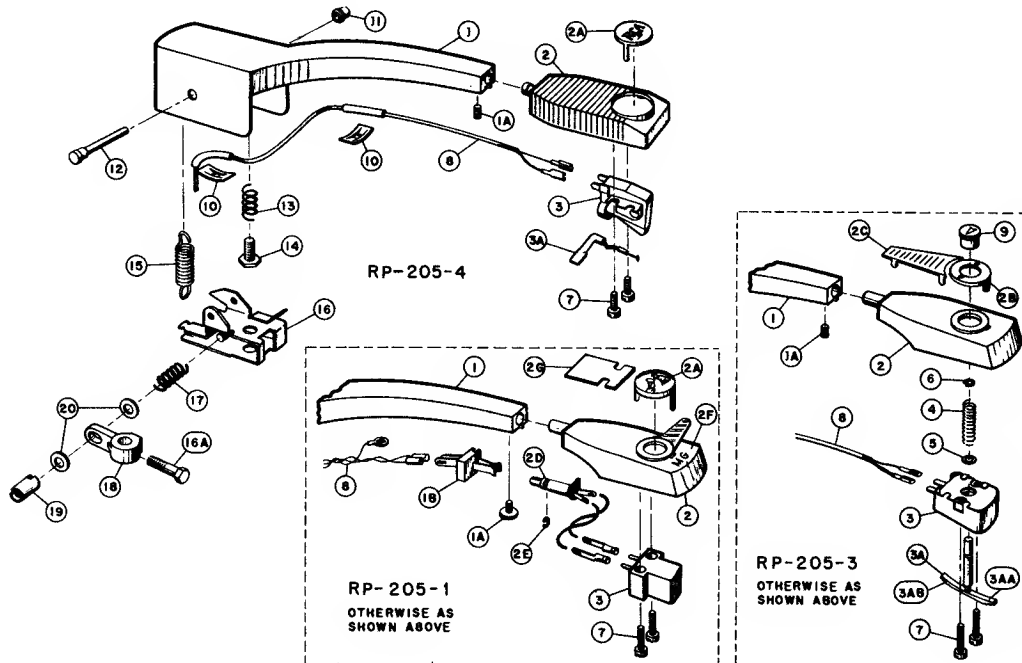

Figure 16—Pickup & Arm Assembly for RP-205-1, RP-205-3 and RP-205-4

RCA Victor Record Changers RP-205 Series, Continued

REMOVAL OF TURNTABLE

The turntable retaining ring (Illust. #7) must be removed before the turntable can be lifted off. Special pliers to remove this type of ring are made by Waldes-Kohinoor, Inc. 47-16 Austel Place, Long Island City, New York.

If the special tool is not available, the retaining ring can be easily removed by using two pointed tools such as awls or ice picks.

When replacing the turntable, it will be necessary to push inward on the idler wheel, that contacts turntable rim, before the turntable will lower to original position. This is best done by pushing with a piece of cardboard or a thin wood stick. Turn the turntable clockwise after idler wheel is pushed inward.

SELECTION OF OPERATING VOLTAGE (RP-205A-1, RP-205A-2)

Remove the turntable as described above, move the VOLTAGE CHANGE SWITCH to "117" for 105-125 volts or "234"

for 210-250 volts to correspond with the available power supply. Replace the turntable using the procedure outlined above.

50 60-CYCLE CONVERSION

Remove the turntable as described above, remove SPRING SLEEVE from motor driveshaft and replace with the specified SPRING SLEEVE for the frequency of the available power supply. Hold motor driveshaft stationary and turn SPRING SLEEVE clockwise when installing. Use care to prevent distortion of spring or damage to motor driveshaft. Replace the turntable using the procedure outlined above.

NOTES.—Motors stamped 936173-1 190 are not recommended for 50-cycle operation.

The 4-pole motor (stamped 971584-1) used on RP-205-1, RP-205-3 and RP-205-4, require a change in the solid sleeve pulley (used for 78, 45 and 33 1/3 r.p.m.) in addition to the change of the spring sleeve (used for 16 2/3 r.p.m.). In addition, a 60 ohm resistor is used in series with the windings of these motors when converted for operation on 50 cycles.

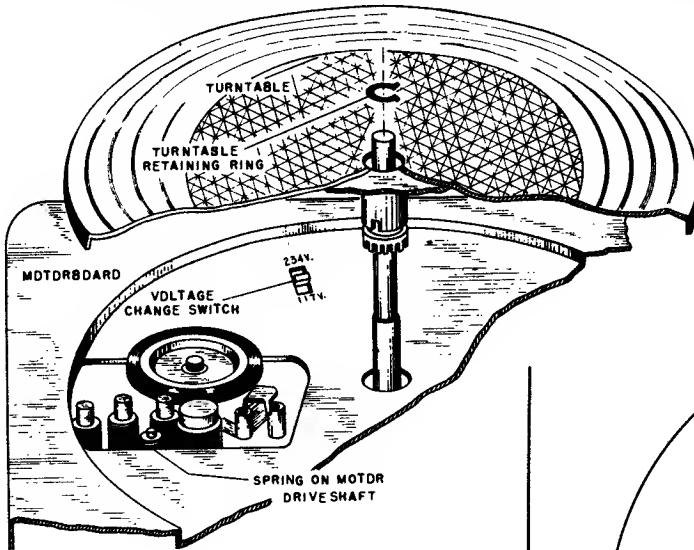

Figure 18—Wiring Diagram for Dual-Voltage Motors

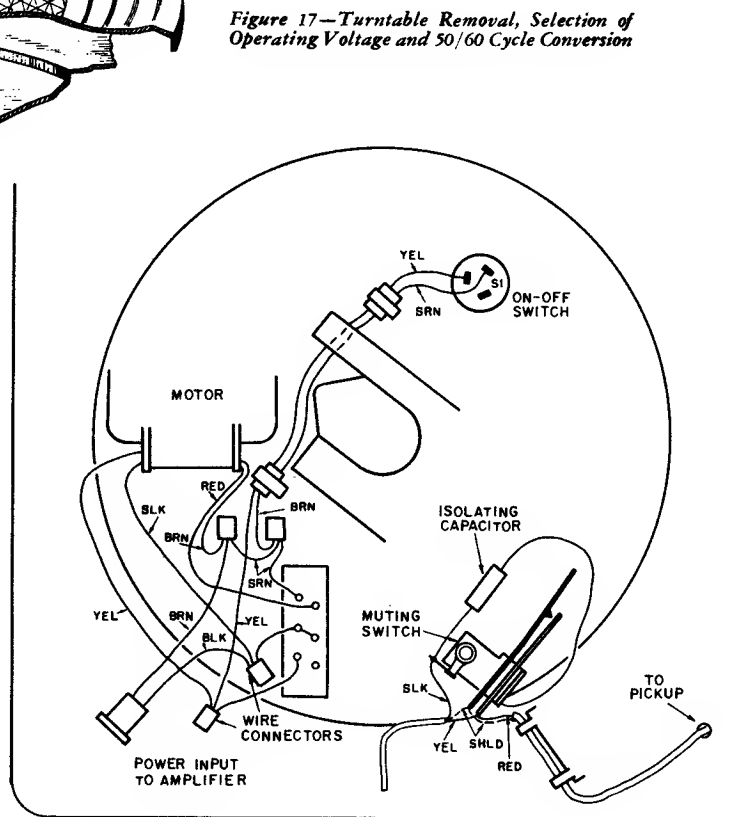

Figure 17—Turntable Removal, Selection of Operating Voltage and 50/60 Cycle Conversion

STYLUS FORCE

The stylus force used with #100653 ceramic pickup is 7 to 9 grams. This pickup is used on RP-205-2, RP-205-4, RP-205-6, RP-205A-1 and RP-205A-2.

The stylus force used with variable reluctance pickups MI-12110-A and MI-12112-A is 7 to 9 grams. These pickups are designed for use on RP-205-3.

The stylus force used with moving coil pickup #102956

(1-mil stylus) is 6 to 8 grams. The stylus force used with moving coil pickup #102955 (3-mil stylus) is 10 to 14 grams. The 3-mil pickup head assembly contains a lead weight to attain the desired stylus force. These pickups are used on RP-205-1.

No provision is made for field adjustment of stylus force. The counterbalance spring to be used on a particular model of record changer is selected to give the desired stylus force.



RAYTHEON MANUFACTURING COMPANY

6RT1 CHASSIS

MODELS: T-150-1, T-150-2, T-150-3, T-150-4, & T-150-5

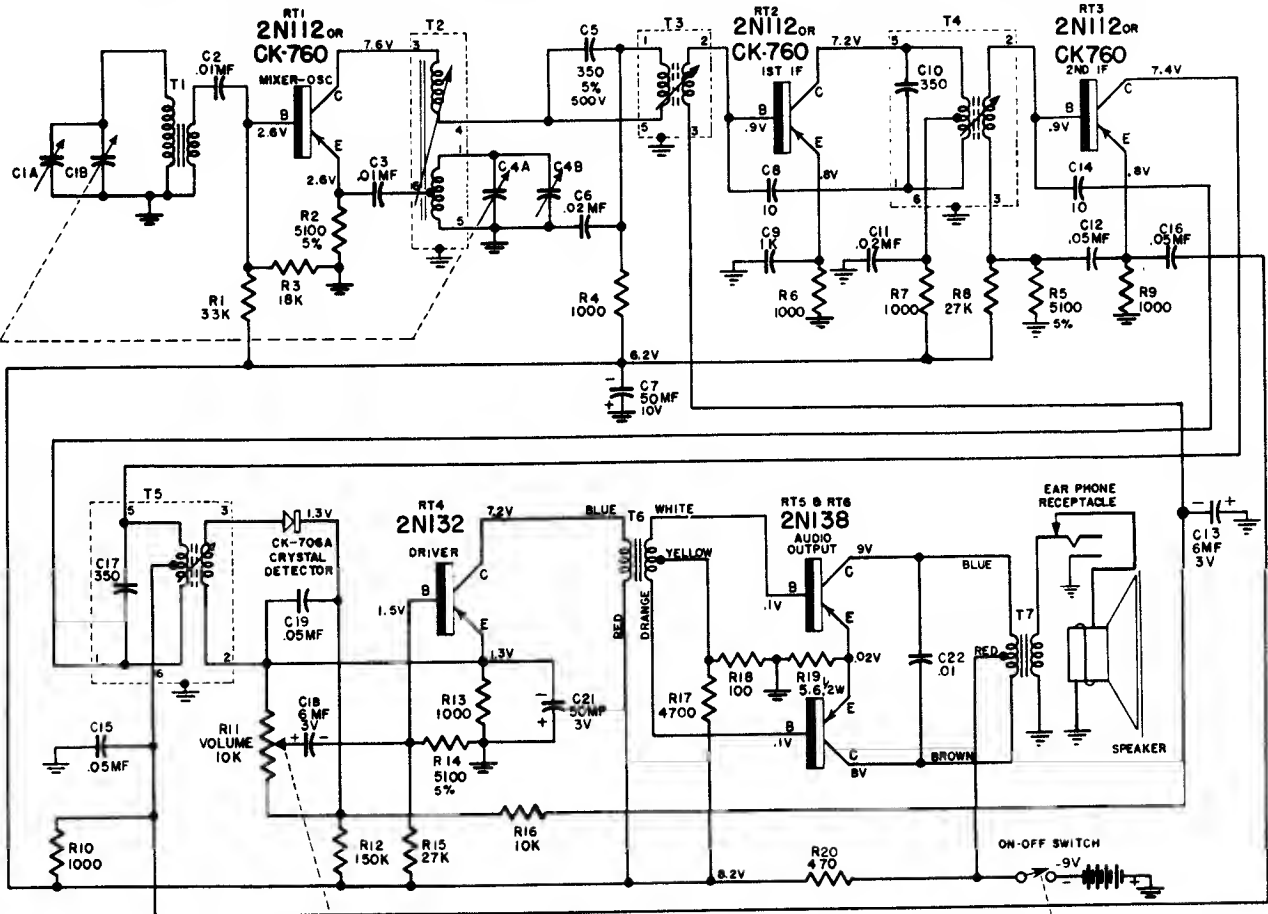

R17 changed from 4700 ohm to 3900 ohm, 1/4 watt, 10%.

**BATTERY REPLACEMENT**

The battery should be the first component checked when the radio is presented for service, since the battery voltage decreases with use and age. The battery voltage should be checked at the battery cable connections with the receiver turned on, and after at least five minutes of operation. Batteries have a tendency to reactivate (re-charge) when not in use, and a true test of the batteries capabilities can not be determined until sufficient current has been drawn from the battery. If the battery is found to be dead, the receiver should be checked for a short circuit before the replacement battery is installed. Disconnect battery and measure resistance with an ohmmeter at the battery cable connections. Ohmmeter will indicate approximately 2100 ohms with positive lead to chassis, approximately 170 ohms with negative lead to chassis and approximately 3200 ohms with all transistors out of circuit with either meter lead to chassis. Battery replacement should be performed when the sound output is noticed to be muffled or distorted with a decrease in total output.

**NOTES**

RESISTOR VALUES ARE IN OHMS, 1/4 WATT, 10% TOLERANCE, UNLESS OTHERWISE SHOWN

CAPACITOR VALUES ARE IN MICRO-MICROFARADS, UNLESS OTHERWISE SHOWN DC WORKING VOLTAGE IS 25V UNLESS OTHERWISE SHOWN

DC VOLTAGE READINGS TAKEN WITH VTVM, NO SIGNAL IN INPUT AND BATTERY VOLTAGE - 9VDC. VOLTAGES WILL VARY WITH TRANSISTOR CHANGES. ALL VOLTAGES ARE NEGATIVE.

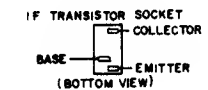
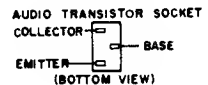
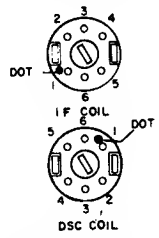
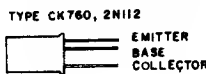
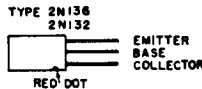

**OHMMETER READINGS**

When using an ohmmeter to check continuity and resistance readings, caution must be observed. It is important to know the internal battery voltage of the ohmmeter as damage could result due to excessive voltage being applied to the circuit by the ohmmeter.



RAYTHEON MANUFACTURING COMPANY

7RT4 CHASSIS

MODEL T-2500

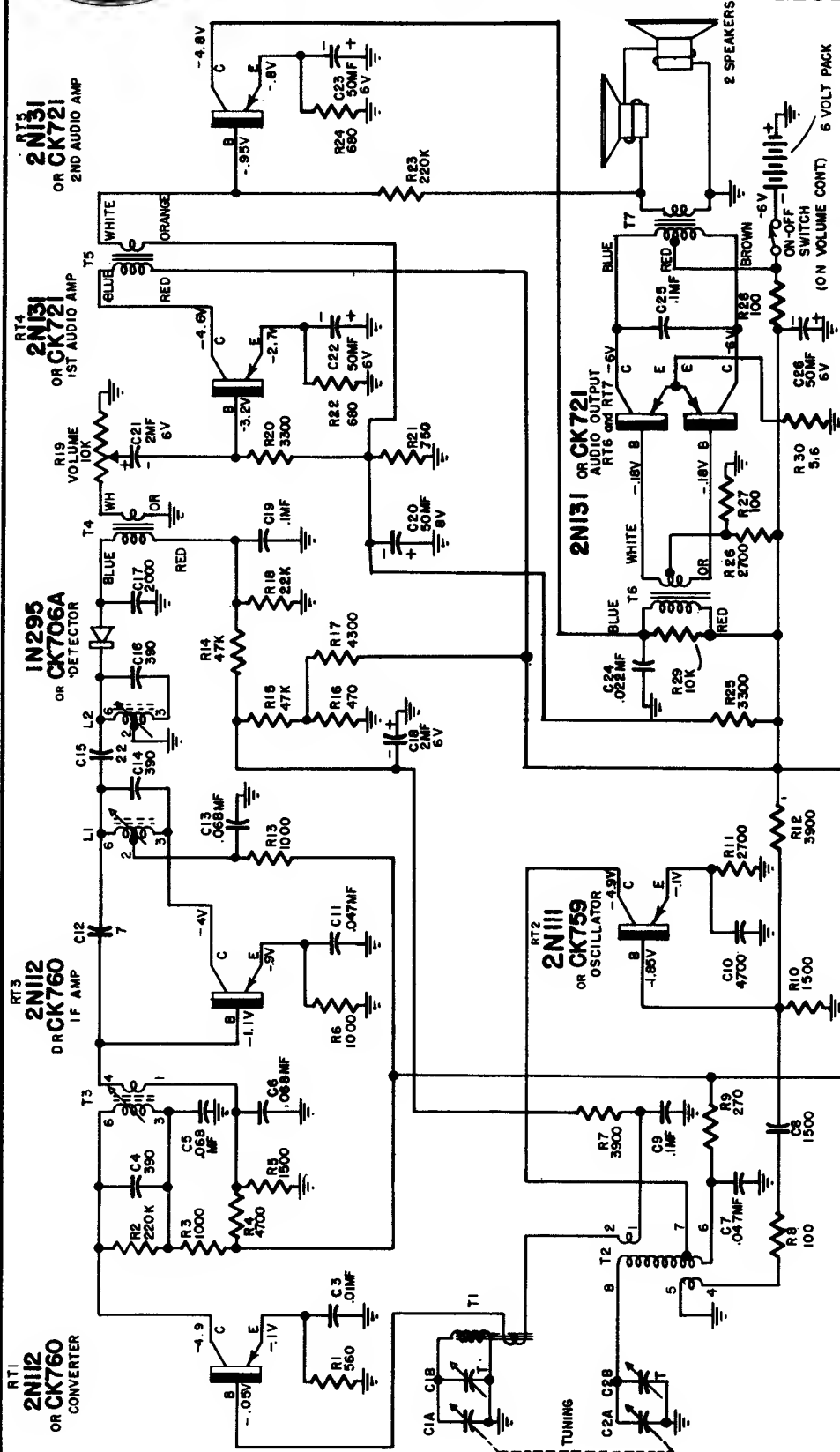

**SPECIFICATIONS**

- Power Supply ..... 6 volts D.C.
- Frequency Range ..... 540 to 1600 KC.
- Intermediate Frequency ..... 455 KC.
- Selectivity ..... At 1000 KC, 52. KC at 1000 x signal
- Sensitivity ..... 200 u.v. per meter
- Power Output ..... 100 m. w.
- Speakers ..... (Dual) 5/4" P.M., v.c. Impedance 8 ohms.

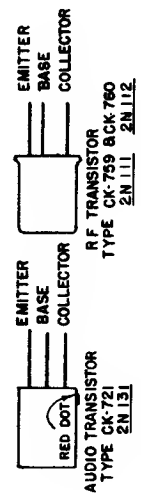

If a transistor is suspected of being defective, substitution will be the only reliable check. Note that sockets are provided for the converter and oscillator transistors while the remaining transistors are soldered in place.

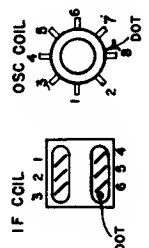

UNLESS OTHERWISE SHOWN, RESISTOR VALUES ARE IN OHMS AND 1/2 WATT.  
CAPACITOR VALUES ARE IN MICRO-MICROFARADS UNLESS OTHERWISE SHOWN.  
DC VOLTAGE READINGS TAKEN WITH VTVM, NO SIGNAL INPUT AND BATTERY VOLTAGE -6VDC. VOLTAGES WILL VARY WITH TRANSISTOR CHANGES.

# SEARS, ROEBUCK and CO.

CHASSIS NUMBER 528.46500

MODEL 7018

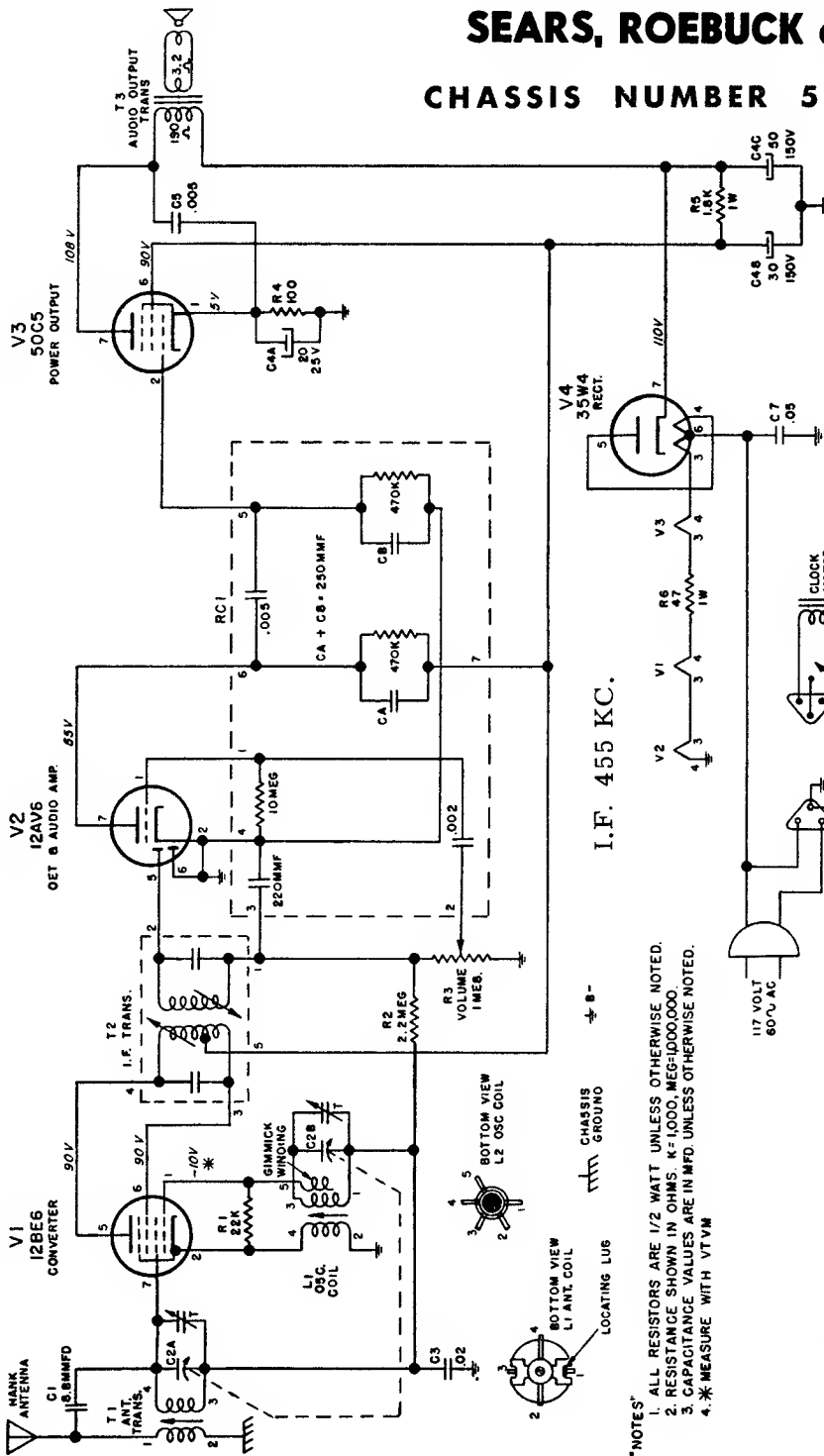

I.F. 455 KC.

- RESISTORS**  
(All resistors 1/2 w., 10% unless otherwise noted)
- R1 60-22302 22K ohm, 20%
  - R2 60-22502 2.2 megohm, 20%
  - R3 24-237 1 megohm, VOLUME
  - R4 60-10102 100 ohm, 20%
  - R5 60-18211 1.8K ohm, 1 w.
  - R6 60-47011 47 ohm, 1 w.
  - RC1 13-10-3 Couplate (PC-159)

- \*NOTES\***
1. ALL RESISTORS ARE 1/2 WATT UNLESS OTHERWISE NOTED.
  2. RESISTANCE SHOWN IN OHMS. K=1,000, MEG=1,000,000.
  3. CAPACITANCE VALUES ARE IN MFD. UNLESS OTHERWISE NOTED.
  4. \* MEASURE WITH VTVM



BOTTOM VIEW OF TUBE SOCKETS SHOWING TERMINAL NUMBERING

SCHEMATIC LOCATION	PART NUMBER	DESCRIPTION
C1	20-27-0	Tubular, Gimmick, 6.8 mmfd., 500 v., 10%
C2 A & B	19-252	Variable, TUNING
C3, C6	16-20343	Tubular, .02 mfd., 400 v.
C4 A, B, & C	18-211-2	Electrolytic, 20 mfd., 25 v., (A); 30 mfd., 150 v., (B); 50 mfd., 150 v., (C)
C5	15-50216	Disc, .005 mfd., 500 v., GP
C7	16-50343	Tubular, .05 mfd., 400 v.

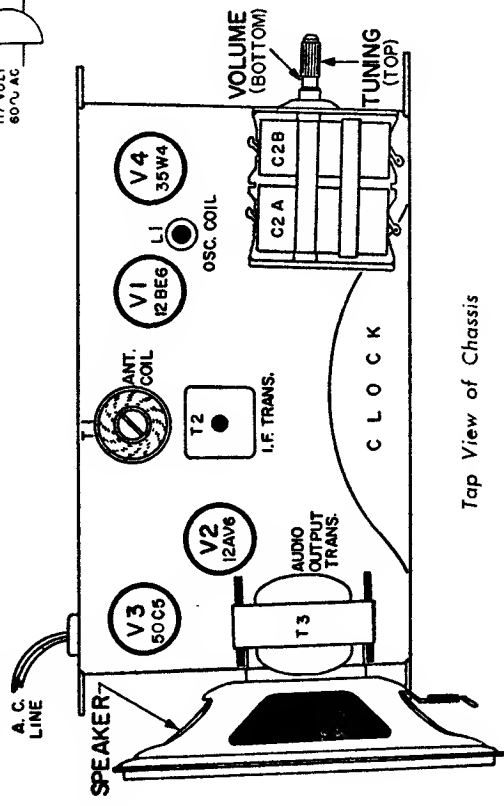

# SEARS, ROEBUCK and CO.

## CHASSIS NUMBER 528.46600

Model 7020, 7021, 7022

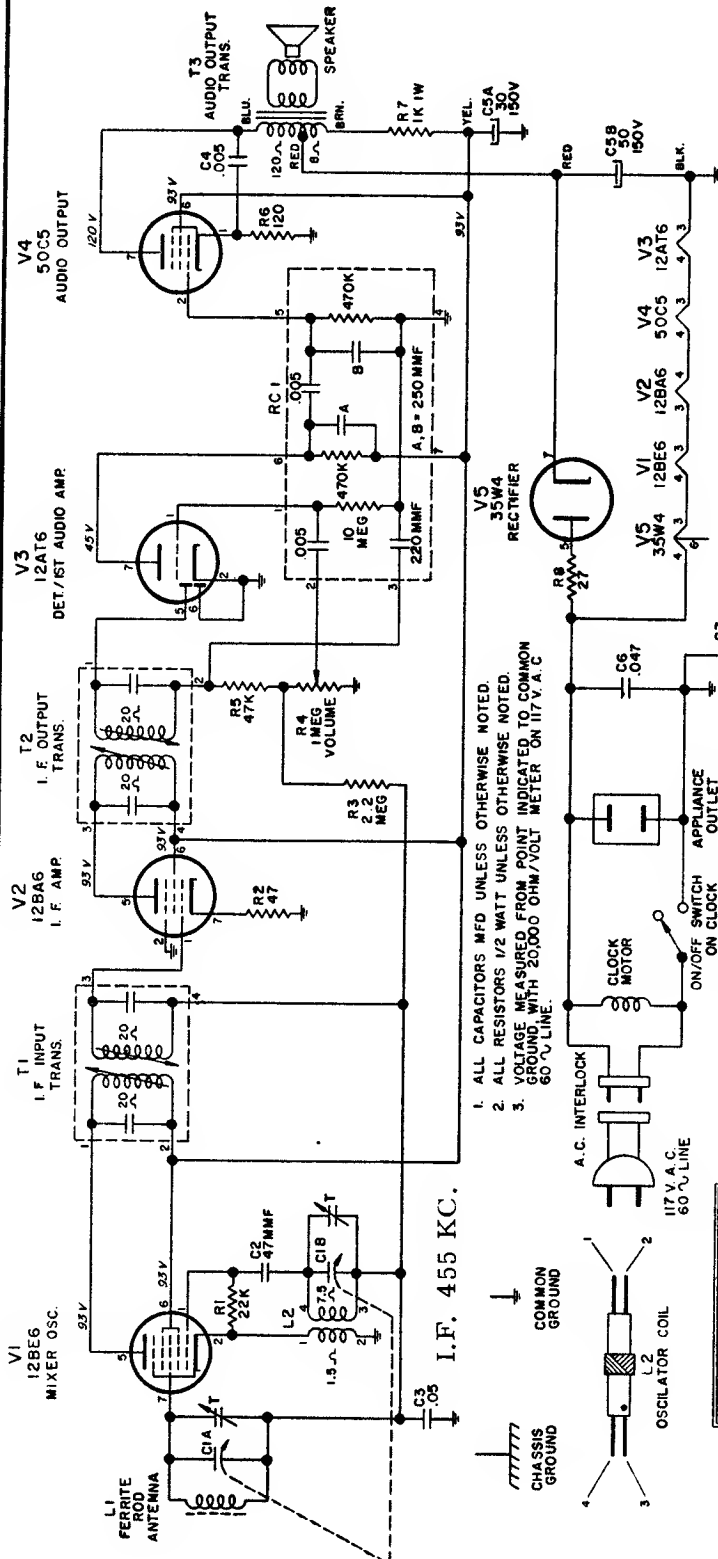

1. ALL CAPACITORS MFD UNLESS OTHERWISE NOTED.
2. ALL RESISTORS 1/2 WATT UNLESS OTHERWISE NOTED.
3. VOLTAGE MEASURED FROM POINT INDICATED TO COMMON 60 V. A.C.

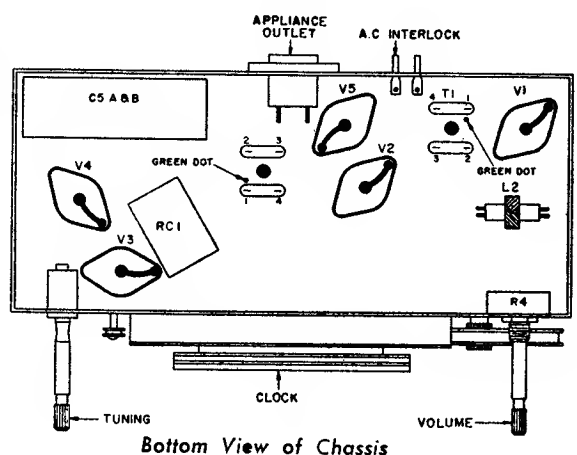
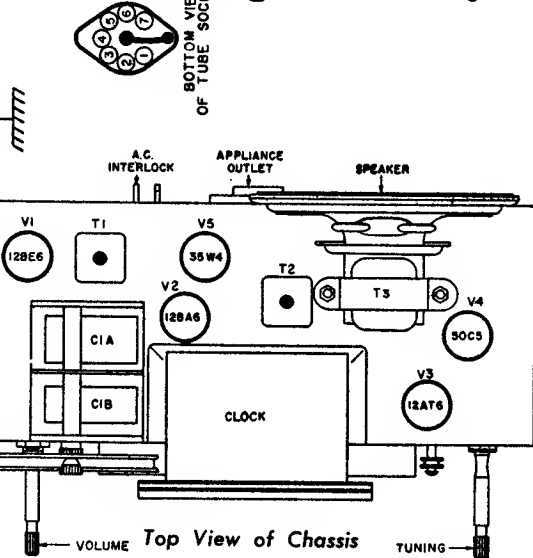
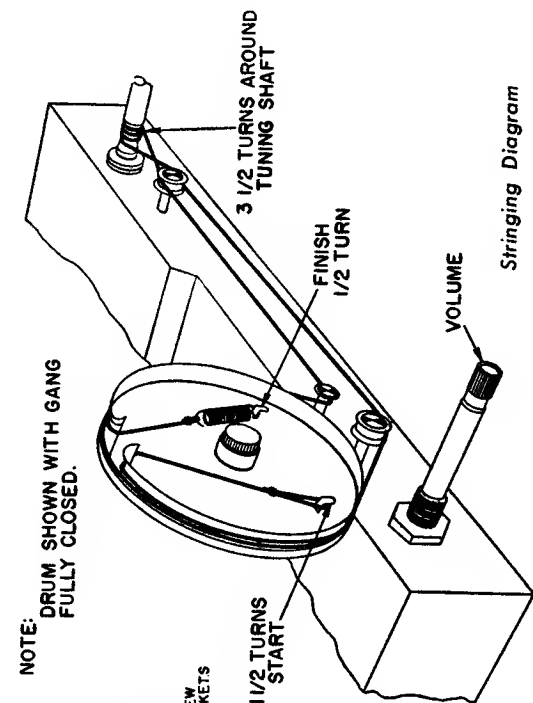



# SEARS, ROEBUCK and CO.

## SILVERTONE PORTABLE RADIO CHASSIS NUMBER 528.48000

### MODEL 7222

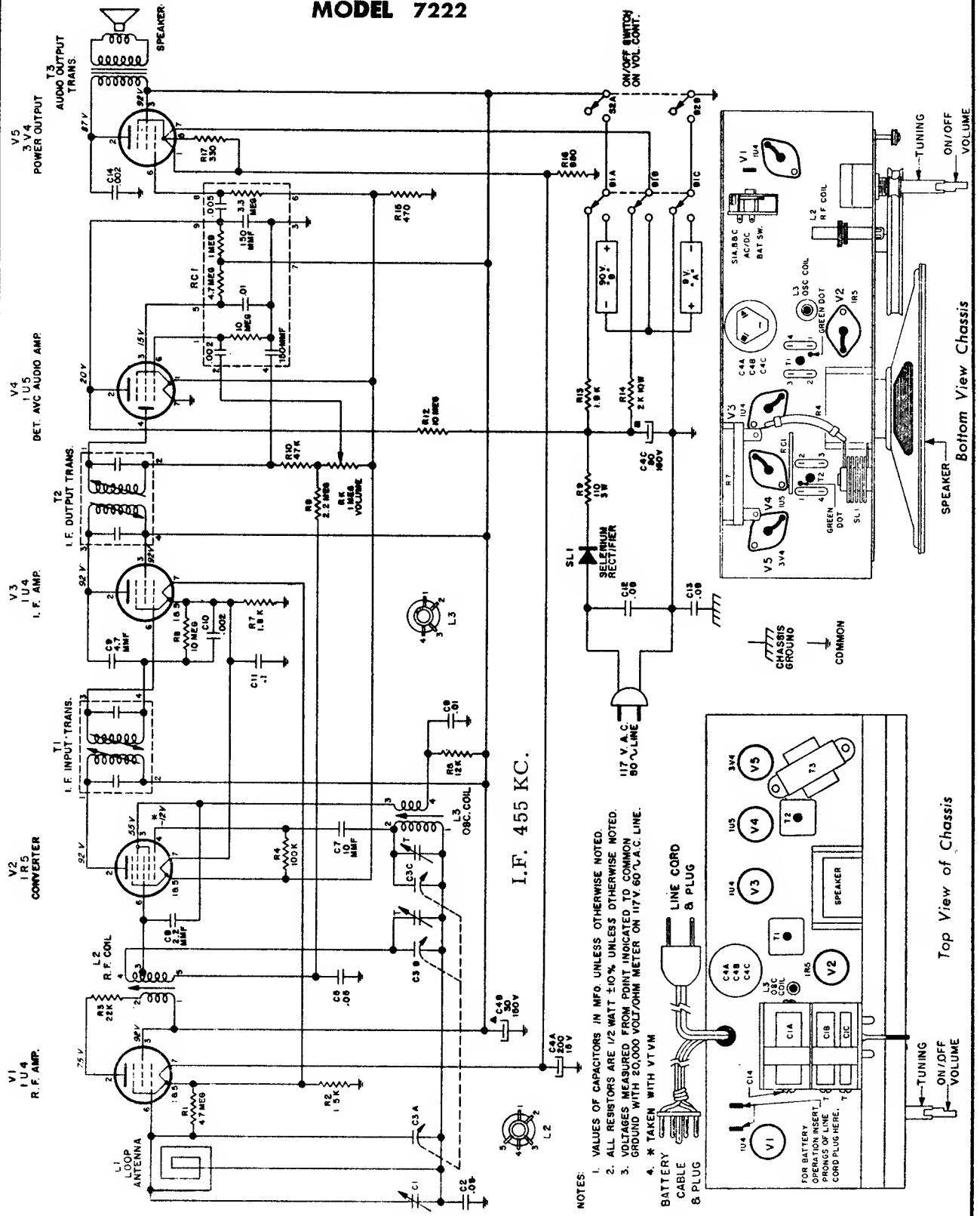

- NOTES:
1. VALUES OF CAPACITORS IN MFD. UNLESS OTHERWISE NOTED.
  2. ALL RESISTORS ARE 1/2 WATT ±10% UNLESS OTHERWISE NOTED.
  3. VOLTAGES MEASURED FROM POINT INDICATED TO COMMON GROUND WITH 20,000 VOLT/OHM METER ON 117V 60°C.A.C. LINE.
  4. \* TAKEN WITH VTVM

# SEARS, ROEBUCK and CO.

SILVERTONE CALENDAR CLOCK-RADIO CHASSIS NUMBER 528.46700

528.46701

MODEL NUMBERS

7025  
7026  
7027

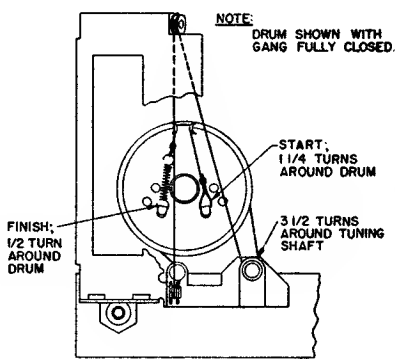

Dial Stringing Diagram

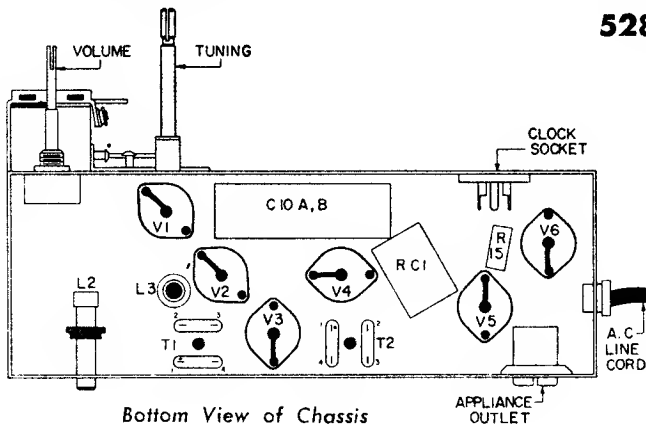

Bottom View of Chassis

I.F. 455 KC.

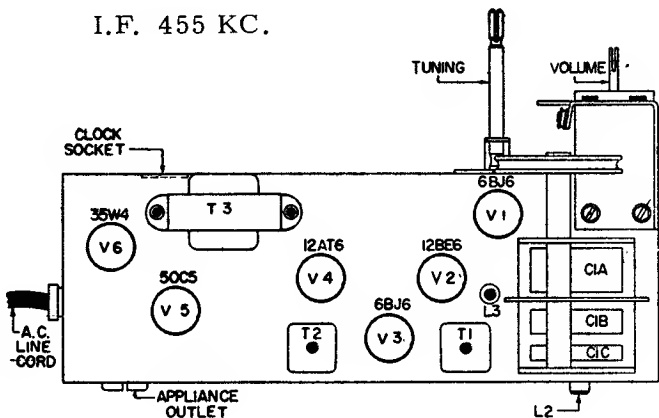

Top View of Chassis

SCHEMATIC LOCATION	PART NUMBER	DESCRIPTION
--------------------	-------------	-------------

### CAPACITORS

C1 A, B, & C	19-23-3	Variable, TUNING (Inc. Drum)
C2, C11	16-50343	Tubular, .05 mfd., 400 v.
C3	16-50323	Tubular, .05 mfd., 200 v
C4	15-470168	Disc, 47 mmfd., 500 v., N3300
C9	15-50217	Disc, .005 mfd., 500 v., GMV
C10 A & B	18-11-2	Electrolytic, 30-70 mfd., 150 v.
C12	20-447-1	Tubular, .047 mfd, 400 v. (Special, No Substitute)

### TRANSFORMERS AND COILS

L1	82-108	Coil, Ant. Loop and Back
L2	10-5-1	Coil, R.F.
L3	10-4-4	Coil, Oscillator
T1	10-45-2	Transformer, I.F. Input
T2	10-46-2	Transformer, I.F. Output
	83-421	Clip, I.F. Mtg. (2)
T3	80-312	Transformer, Audio Output

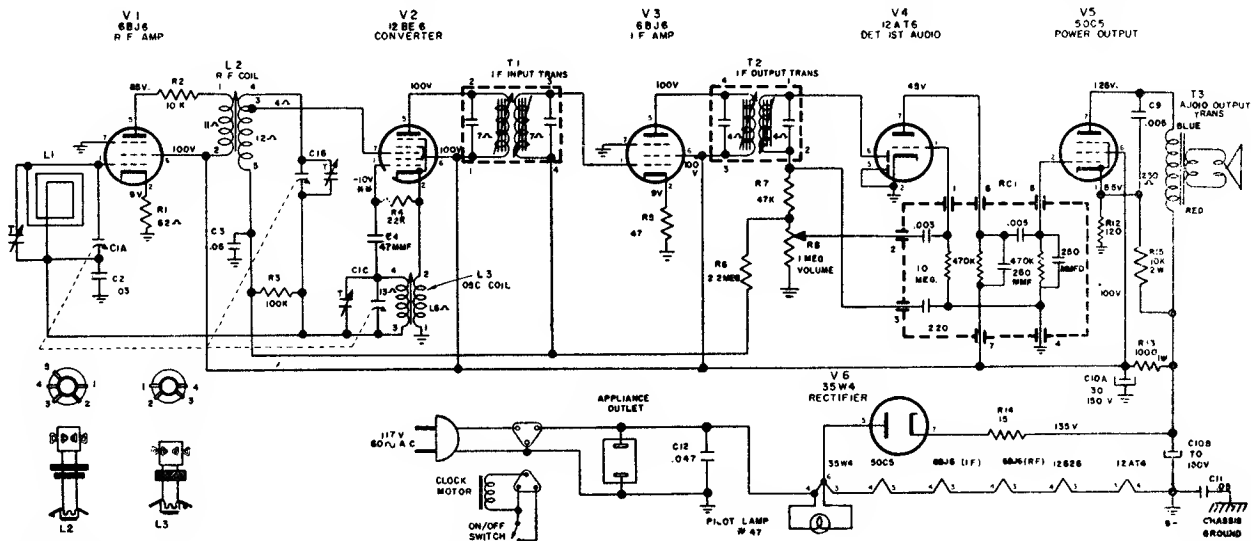

### NOTES

- VALUES OF CAPACITORS IN MFD UNLESS OTHERWISE NOTED
- ALL RESISTORS 1/2 WATT UNLESS OTHERWISE NOTED

- VOLTAGES MEASURED FROM POINT INDICATED TO COMMON GROUND WITH 20,000 OHM/VOLT METER ON HTV, A.C., 80 V. LINE
- \* TAKEN WITH VTVM

SPARTAN DIVISION  
THE MAGNAVOX COMPANY

# CHASSIS CR-734

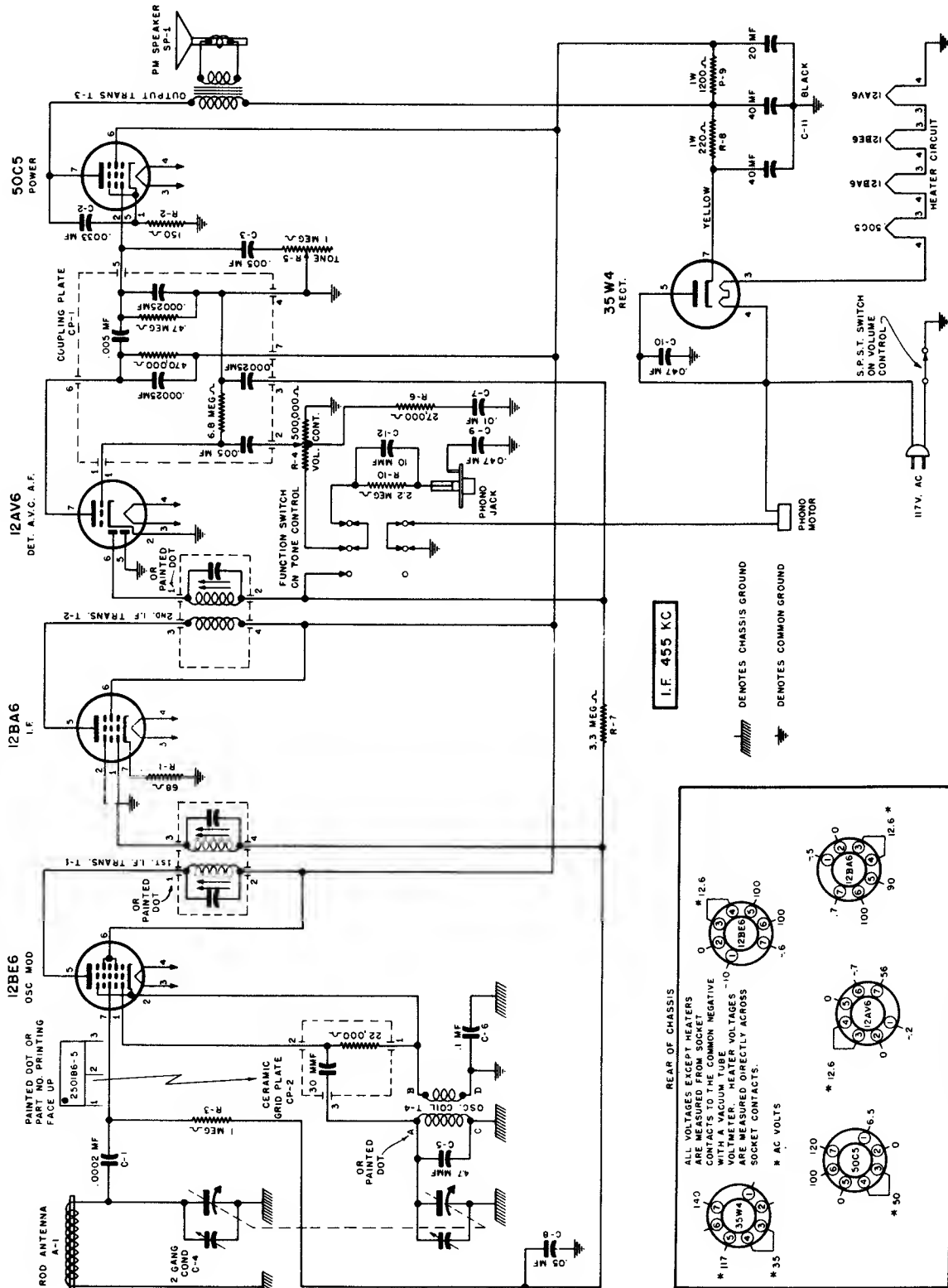

I.F. 455 KC

/// DENOTES CHASSIS GROUND  
⚡ DENOTES COMMON GROUND

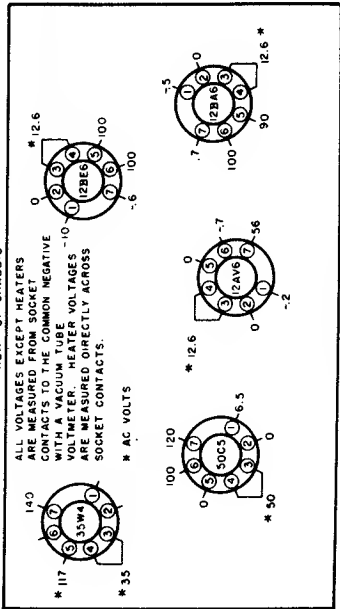

SYLVANIA ELECTRIC PRODUCTS INC.

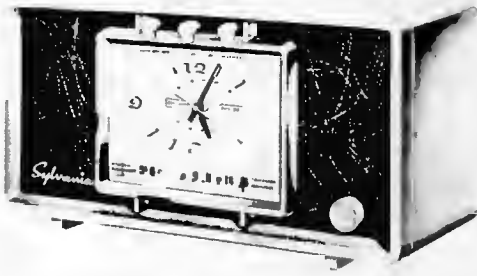

**CHASSIS: I-602-9**  
**MODELS: 2302**

- SCHEMATIC NOTES:**
1. Voltages measured on operating meter. All AC voltages 117 V AC and signal input kept to minimum.
  2. Coil resistances are average values and are taken with component connected in circuit.
  3. Voltages or resistance readings are not to be taken on small or widely variable values.
  4. Intermediate frequency 455 KC.
  5. Combined values of X and Y equals 100 McF.

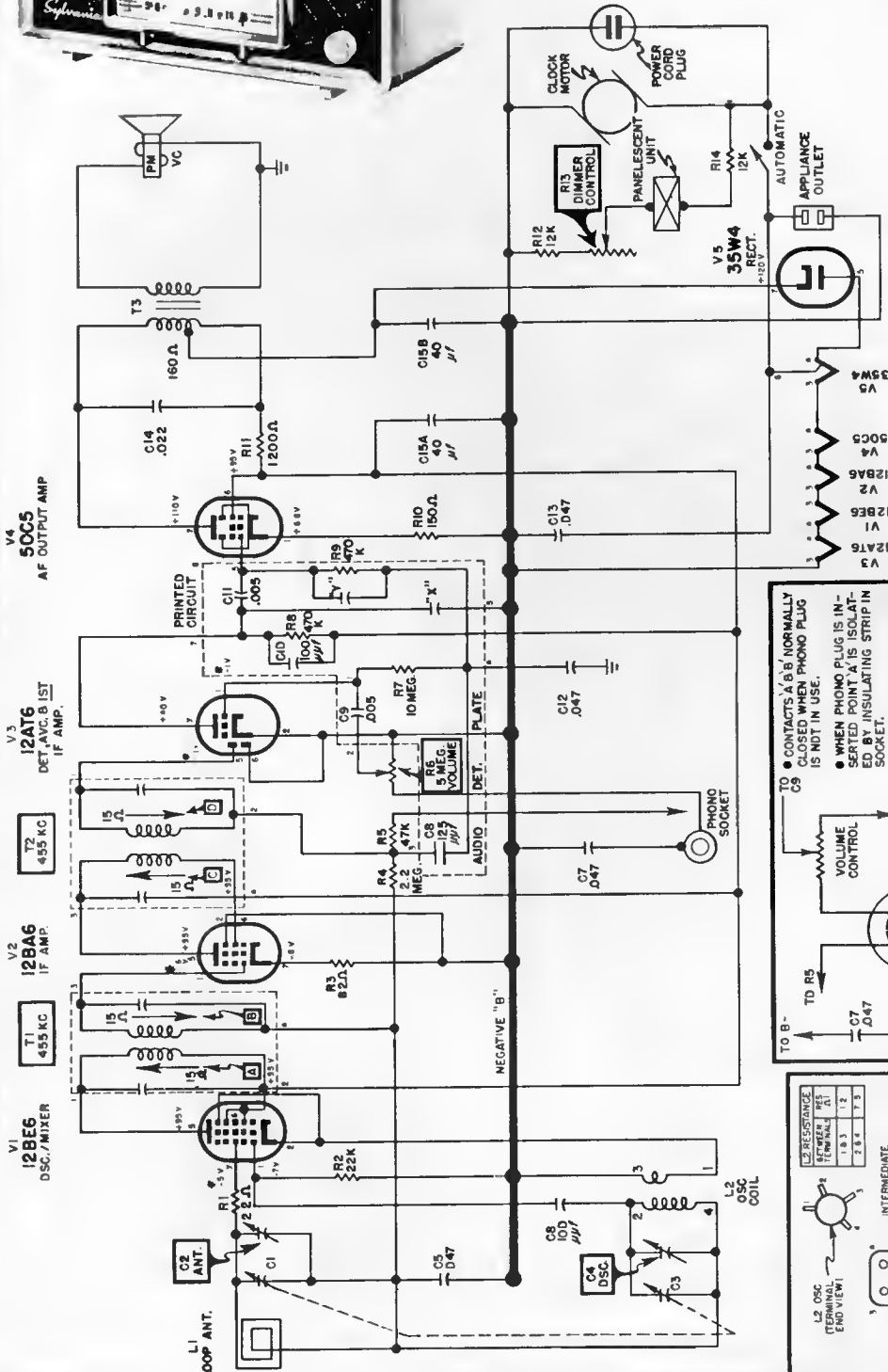

**CHASSIS-REMOVAL**

- Disconnect power cord from AC outlet.
- Remove clock control, tuning and volume knobs.
- Remove (3) chassis bolts underneath cabinet.
- Slide chassis, clock and backcover from cabinet.

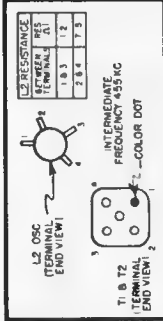
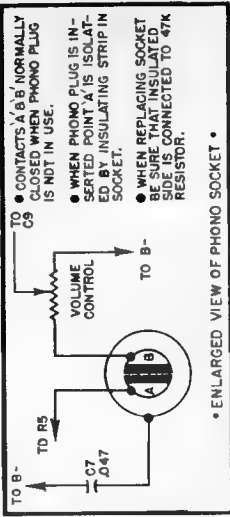

**SCHEMATIC DIAGRAM—SYLVANIA RADIO CHASSIS NO. I-602-9**

VOLUME R-17, MOST-OFTEN-NEEDED 1957 RADIO SERVICING INFORMATION

SYLVANIA Chassis 1-607-5, -6, Models 2101, 2202

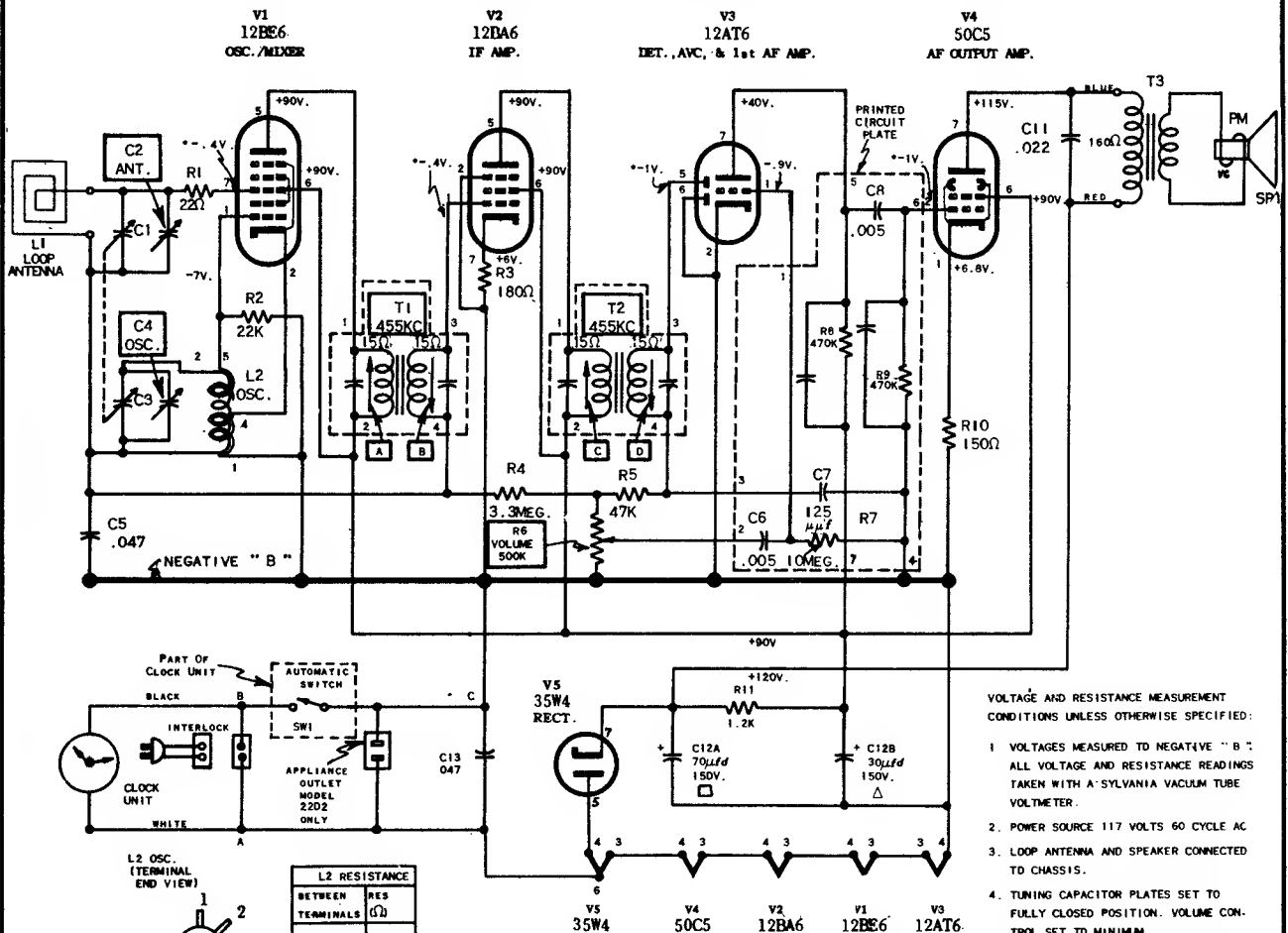

VOLTAGE AND RESISTANCE MEASUREMENT CONDITIONS UNLESS OTHERWISE SPECIFIED:

1. VOLTAGES MEASURED TO NEGATIVE "B". ALL VOLTAGE AND RESISTANCE READINGS TAKEN WITH A SYLVANIA VACUUM TUBE VOLTMETER.
2. POWER SOURCE 117 VOLTS 60 CYCLE AC
3. LOOP ANTENNA AND SPEAKER CONNECTED TO CHASSIS.
4. TUNING CAPACITOR PLATES SET TO FULLY CLOSED POSITION. VOLUME CONTROL SET TO MINIMUM.
5. VOLTAGE AND RESISTANCE VALUES SHOWN ARE AVERAGE READINGS. VARIATIONS MAY BE NOTED DUE TO NORMAL PRODUCTION TOLERANCES.
6. VOLTAGE AND RESISTANCE READINGS ARE NOT SHOWN WHERE TOO SMALL.
7. VOLTAGE READINGS MARKED "..." ARE WIDELY VARIABLE, DEPENDENT UPON SIGNAL CONDITIONS.

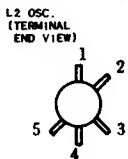
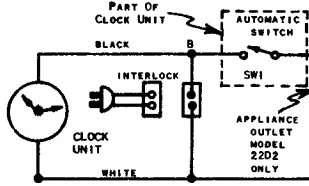

L2 RESISTANCE	
BETWEEN TERMINALS	RES (Ω)
2 & 3	7.5
4 & 1	1.0



**CHASSIS: 1-607-5, -6  
MODELS: 2101, 2202**

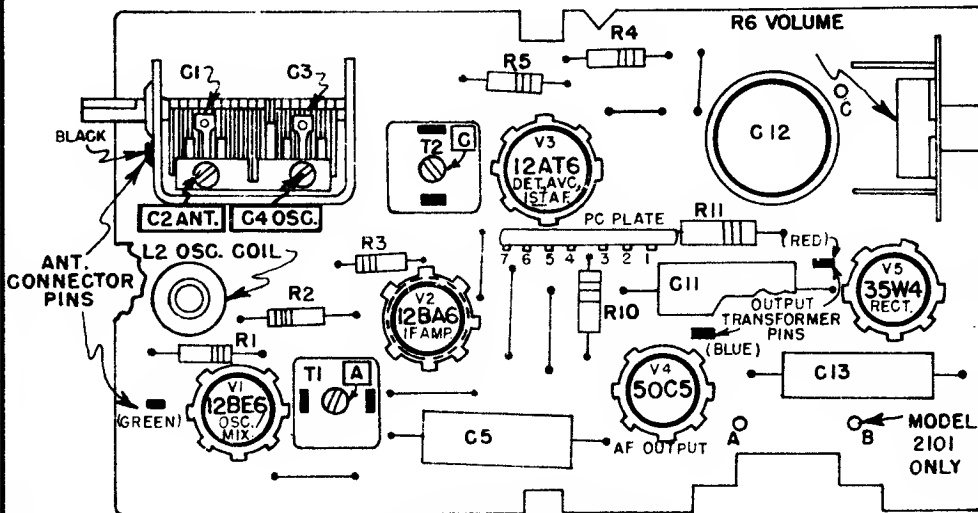

PARTS LAYOUT - TOP

METHOD OF HOOKING UP 117V. POWER INPUT TO CHASSIS WHEN CHASSIS IS REMOVED.

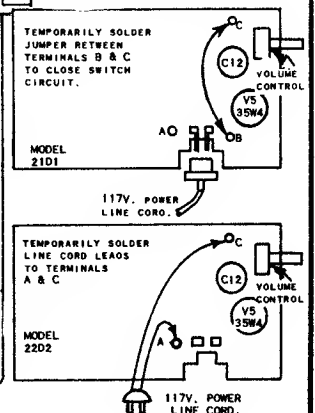

SYLVANIA Chassis 1-615-1, -2, Models 1202, 2301

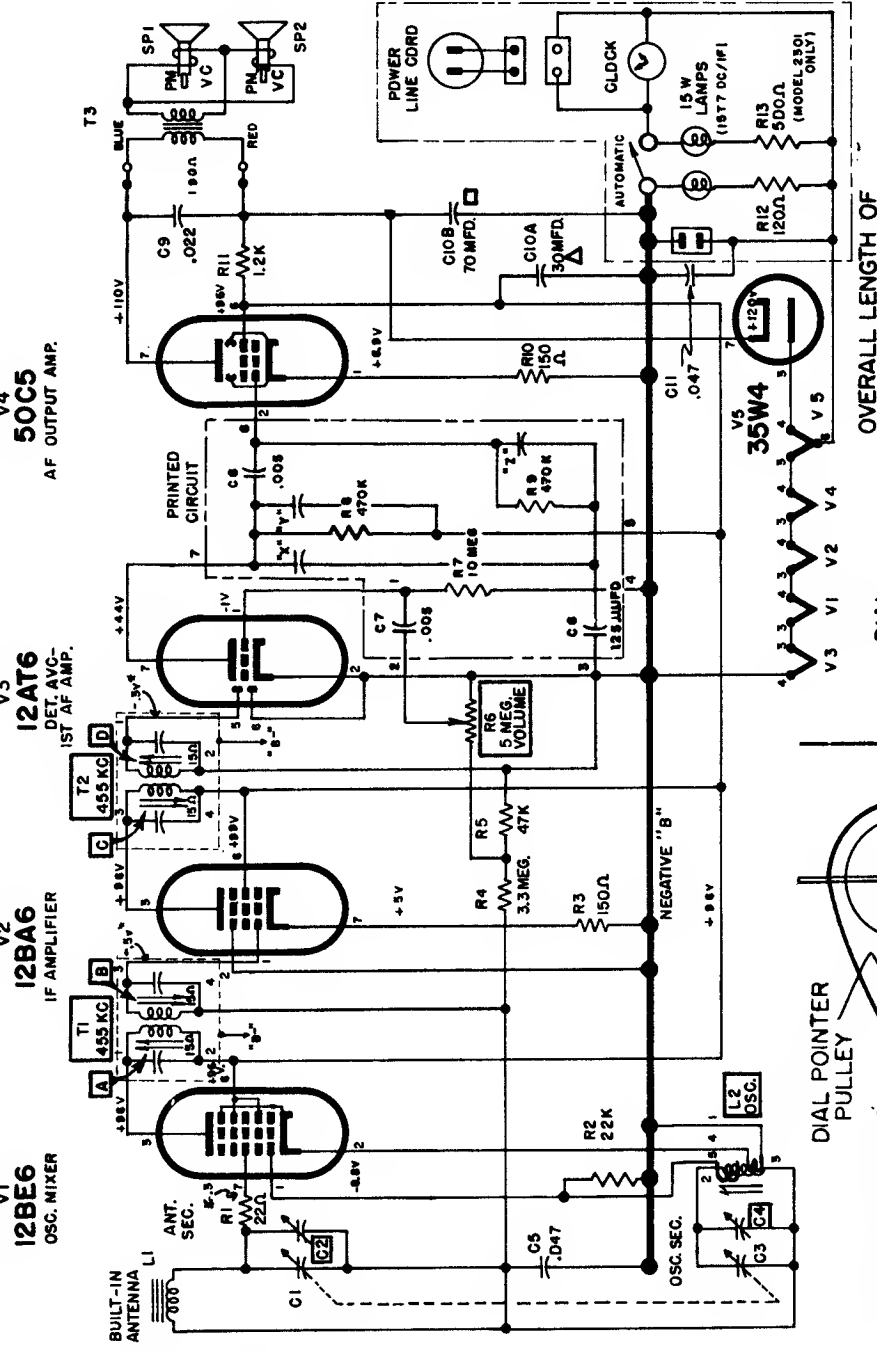
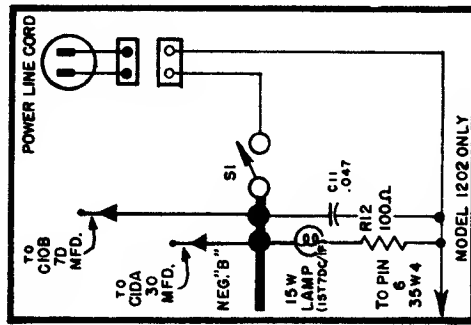
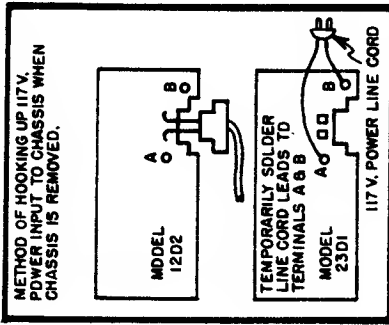

VOLTAGE READINGS MARKED ..... ARE WIDELY VARIABLE, DEPENDENT UPON SIGNAL CONDITIONS. SUM OF 'X', 'Y', AND 'Z' CAPACITORS IS 100 MMFD.

L2 RESISTANCE BETWEEN RES. TERMINALS (Ω)	RES. VALUE
2 & 3	7.0
4 & 1	1.0

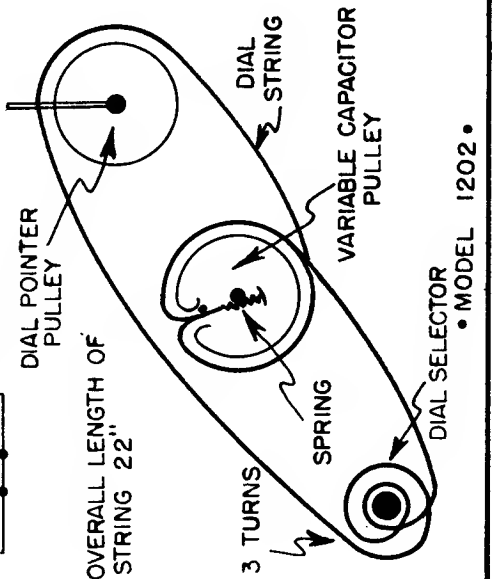
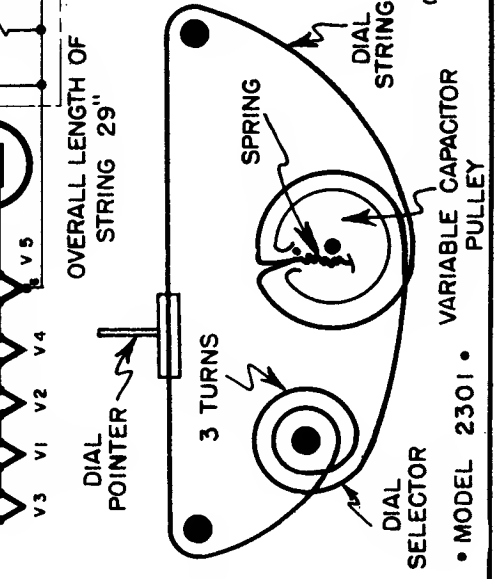
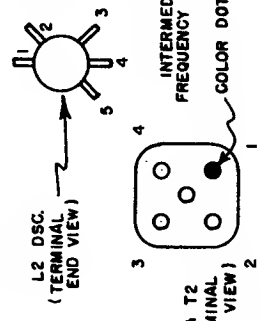

SYLVANIA ELECTRIC PRODUCTS INC.

**CHASSIS: 1-612-1**  
**MODELS: 3401 SERIES**

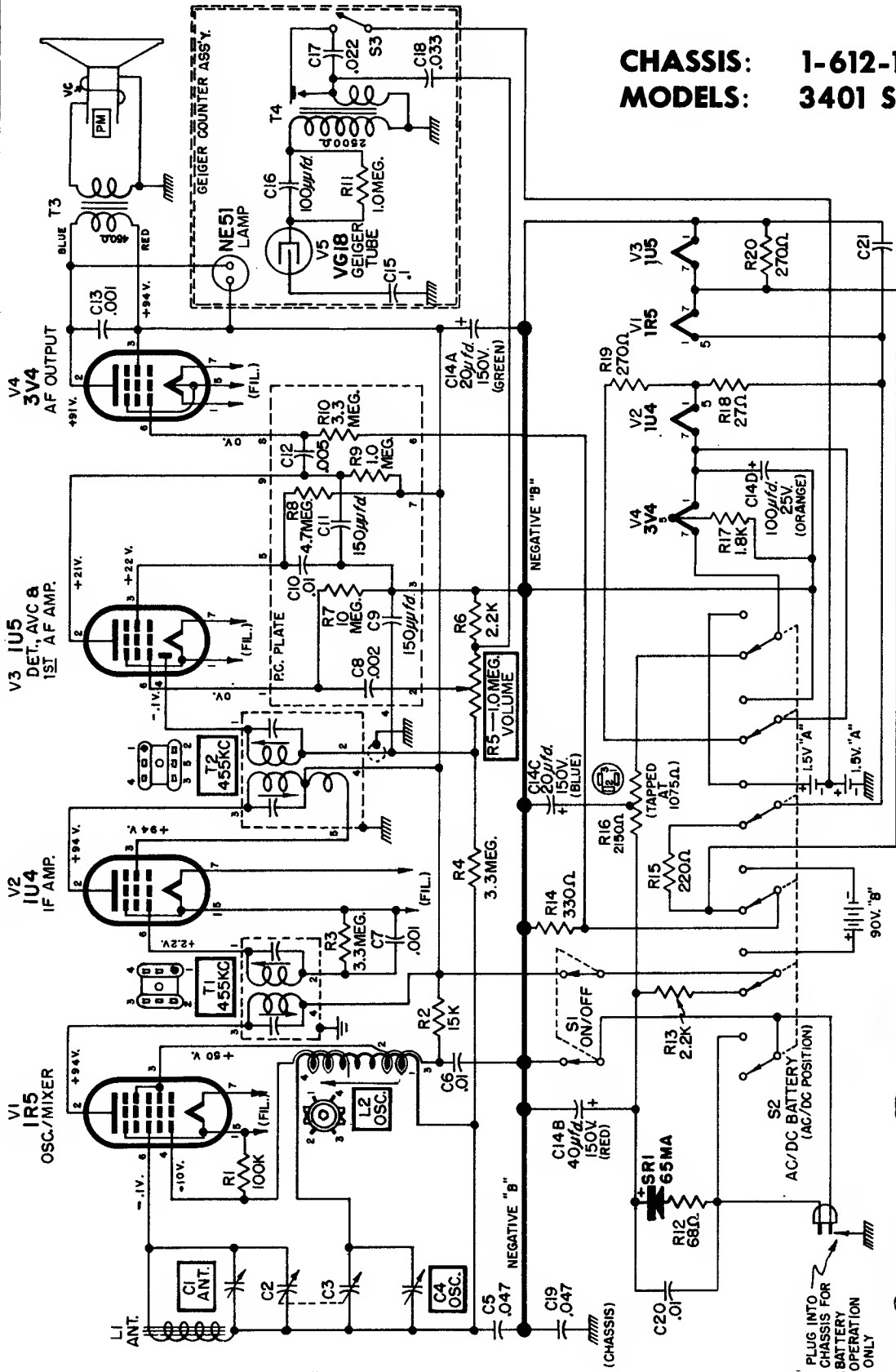

**SCHEMATIC DIAGRAM: SYLVANIA RADIO CHASSIS 1-612-1**

- SCHEMATIC NOTES:**
1. VOLTAGE MEASURED TO NEGATIVE USING SYLVANIA POLYMER METER POSITION, LINE VOLTAGE 117V AC AND SIGNAL INPUT KEPT TO MIN.
  2. COIL RESISTANCES ARE AVERAGE VALUES AND ARE TAKEN WITH COMPONENT CONNECTED IN CIRCUIT.
  3. VOLTAGE OR RESISTANCE READINGS ARE NOT SHOWN WHERE TOO SMALL OR WIDELY VARIABLE.
  4. INTERMEDIATE FREQUENCY 455KC.
  5. SYMBOL  DESIGNATES CONNECTION TO CHASSIS METAL.

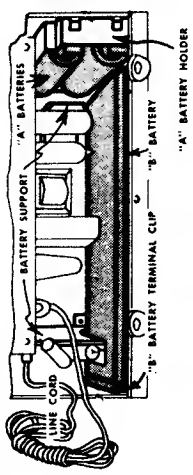

**SYLVANIA**  
RADIO & TELEVISION

**CHASSIS: 1-612-2**

**MODELS: 3202-3304-3303 SERIES**

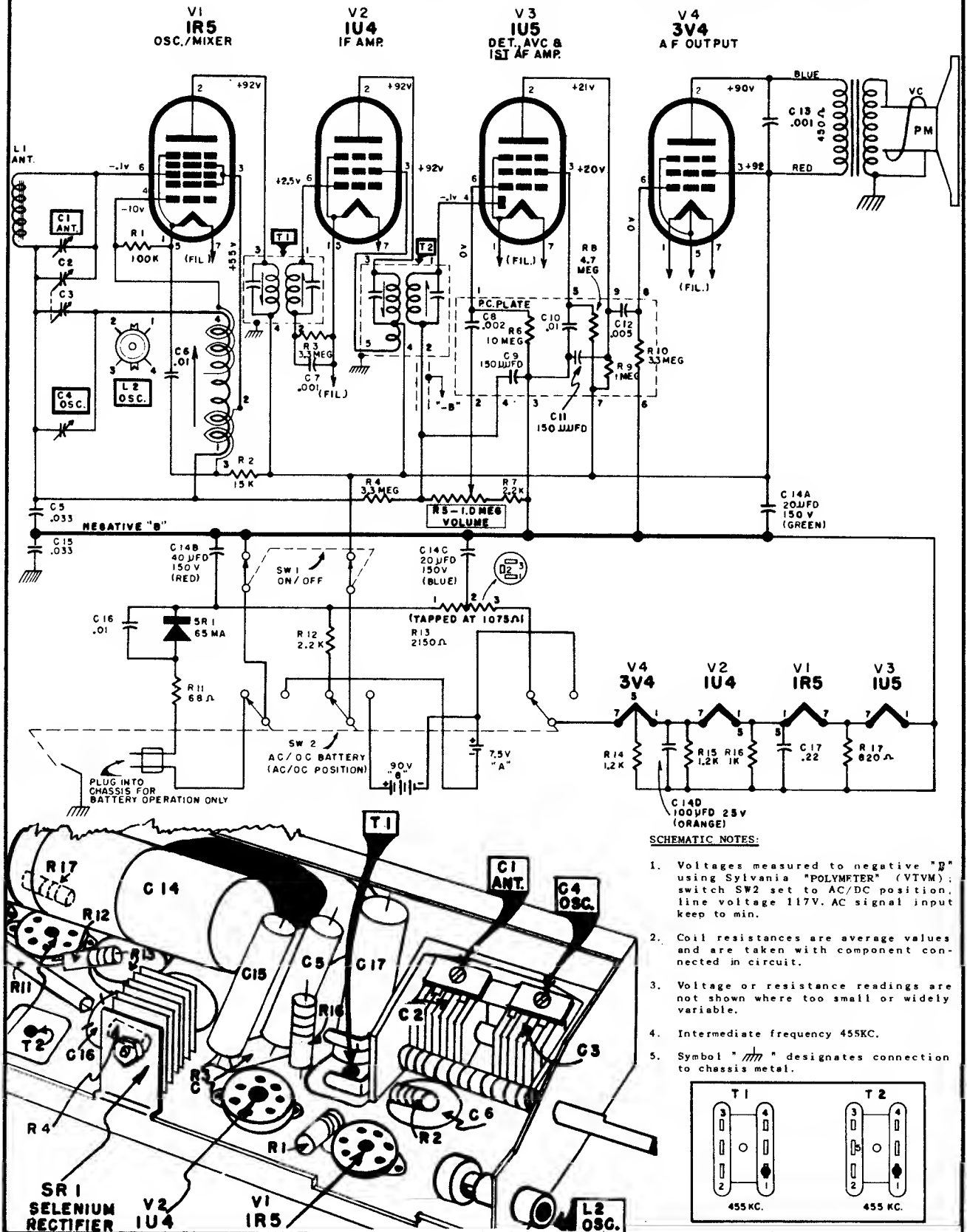



# TRAVLER

## Model 55C42, 55C46

These two models are almost identical electrically. The circuit of Model 55C42 shown below will also apply to 55C46. Separate tube and trimmer location diagrams are shown. Alignment procedure is identical for both models.

Remove the chassis from the cabinet for alignment. A signal generator is required having the following frequencies: 455 KC, 535 KC, 1400 KC, 1630 KC. An output meter should be connected across the speaker.

**FIRST STEP:** Connect the hot lead from the generator to the ANT. section of the gang condenser through a .1 MFD. condenser. The ground lead from the generator must be connected to "B" minus under the chassis. Turn the gang condenser to complete minimum capacity. Set the generator to 455 KC. Adjust the movable iron cores in the IF cans. The IF adjustments are made in the top and in the bottom of the cans. Adjust the cores until a maximum reading is noted on the output meter.

The volume control of the receiver should be turned to maximum during the IF and all subsequent alignment and the generator output as low as possible to prevent the AVC from working and giving false readings.

**SECOND STEP:** With the leads from the generator still connected as in IF alignment, adjust the generator to 1630 KC. Make sure that the gang condenser is turned to complete minimum capacity. Adjust the generator to 1630 KC and adjust the oscillator trimmer of the receiver until the signal is tuned in. Next, turn the gang condenser to complete maximum capacity. Adjust the generator to 535 KC, then adjust the iron core in the end of the oscillator coil until the signal is tuned in. It may be well to recheck the 1630 KC setting to make sure that the adjustment of the iron core has not shifted the frequency.

**THIRD STEP:** Remove the generator leads from the gang condenser and the chassis. Loosely couple the generator to the antenna by laying the hot generator lead near the loop antenna. Set the generator at 1400 KC and tune in the 1400 KC signal on the receiver. Adjust the ANT. trimmer until a maximum signal is noted on the output meter.

No further adjustment should be necessary as the coils and gang condenser in this receiver have been specially handled at the factory to insure proper alignment at the lower frequencies.

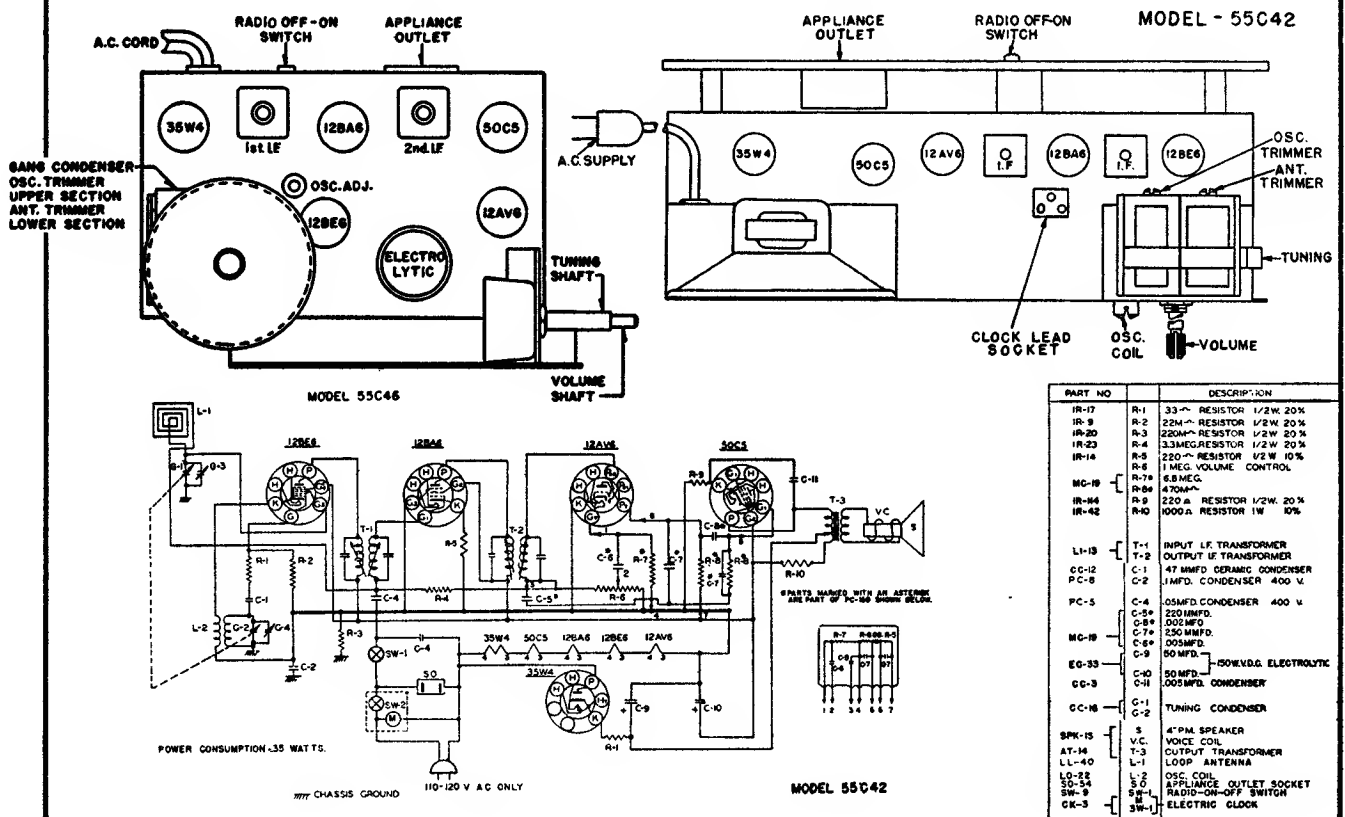

# TRAVLER Model 65C45

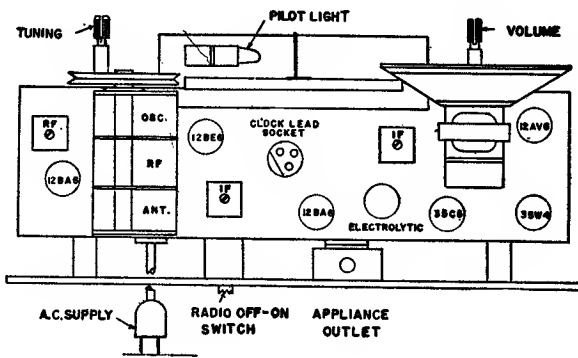
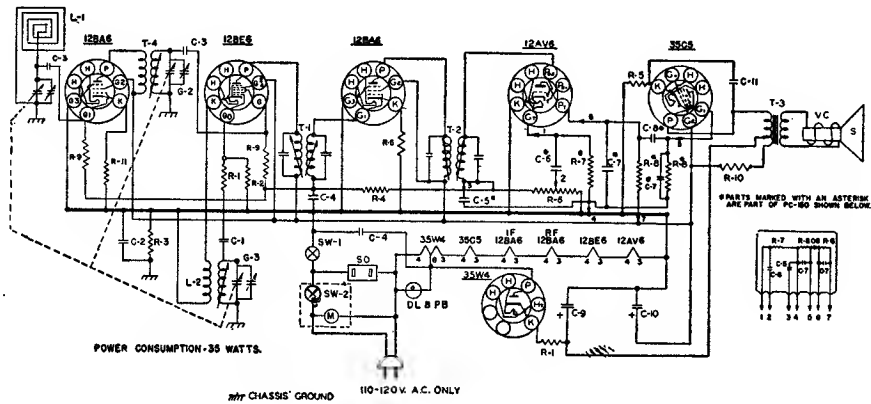

PART NO	DESCRIPTION	PART NO	DESCRIPTION
IR-17	R-1 33 $\Omega$ RESISTOR 1/2W. 20%	CC-12	C-1 47 MMFD CERAMIC CONDENSER
IR-9	R-2 22M $\Omega$ RESISTOR 1/2W. 20%	PC-8	C-2 1MFD. CONDENSER 400 V.
IR-20	R-3 220M $\Omega$ RESISTOR 1/2W. 20%	CC-33	C-3 220 M MFD. CONDENSER
IR-23	R-4 3.3MEG RESISTOR 1/2W. 20%	PL-5	C-4 0.5MFD. CONDENSER 400 V.
IR-14	R-5 220 $\Omega$ RESISTOR 1/2 W. 20%	C-5*	C-5 220 MMFD.
VC-6B	R-6 1 MEG. VOLUME CONTROL	C-6*	C-6 0.02MFD.
MC-19	R-7 6.8MEG.	C-7*	C-7 250 MMFD.
	R-8 470M $\Omega$	C-8*	C-8 0.05MFD.
IR-11	R-9 1MEG. RESISTOR 1/2W. 20%	EC-33	C-9 50 MFD. -150WV.D.C. ELECTROLYTIC
IR-42	R-10 1000 $\Omega$ RESISTOR 1W. 80%	CC-3	C-10 50 MFD.
IR-36	R-11 100 $\Omega$ RESISTOR 1/2W. 20%	CC-19	C-11 100 MFD. CONDENSER
LR-1	T-1 I.F. TRANSFORMER	CC-19	C-12 47 MMFD. CONDENSER
LI-13	T-2 O.U.T.P.U.T. I.F. TRANSFORMER	CC-19	C-13 50 MFD.
			C-14 100 MFD. CONDENSER
			C-15 47 MFD.
			C-16 100 MFD. CONDENSER
			C-17 47 MFD.
			C-18 100 MFD. CONDENSER
			C-19 47 MFD.
			C-20 100 MFD. CONDENSER
			C-21 47 MFD.
			C-22 100 MFD. CONDENSER
			C-23 47 MFD.
			C-24 100 MFD. CONDENSER
			C-25 47 MFD.
			C-26 100 MFD. CONDENSER
			C-27 47 MFD.
			C-28 100 MFD. CONDENSER
			C-29 47 MFD.
			C-30 100 MFD. CONDENSER
			C-31 47 MFD.
			C-32 100 MFD. CONDENSER
			C-33 47 MFD.
			C-34 100 MFD. CONDENSER
			C-35 47 MFD.
			C-36 100 MFD. CONDENSER
			C-37 47 MFD.
			C-38 100 MFD. CONDENSER
			C-39 47 MFD.
			C-40 100 MFD. CONDENSER
			C-41 47 MFD.
			C-42 100 MFD. CONDENSER
			C-43 47 MFD.
			C-44 100 MFD. CONDENSER
			C-45 47 MFD.
			C-46 100 MFD. CONDENSER
			C-47 47 MFD.
			C-48 100 MFD. CONDENSER
			C-49 47 MFD.
			C-50 100 MFD. CONDENSER
			C-51 47 MFD.
			C-52 100 MFD. CONDENSER
			C-53 47 MFD.
			C-54 100 MFD. CONDENSER
			C-55 47 MFD.
			C-56 100 MFD. CONDENSER
			C-57 47 MFD.
			C-58 100 MFD. CONDENSER
			C-59 47 MFD.
			C-60 100 MFD. CONDENSER
			C-61 47 MFD.
			C-62 100 MFD. CONDENSER
			C-63 47 MFD.
			C-64 100 MFD. CONDENSER
			C-65 47 MFD.
			C-66 100 MFD. CONDENSER
			C-67 47 MFD.
			C-68 100 MFD. CONDENSER
			C-69 47 MFD.
			C-70 100 MFD. CONDENSER
			C-71 47 MFD.
			C-72 100 MFD. CONDENSER
			C-73 47 MFD.
			C-74 100 MFD. CONDENSER
			C-75 47 MFD.
			C-76 100 MFD. CONDENSER
			C-77 47 MFD.
			C-78 100 MFD. CONDENSER
			C-79 47 MFD.
			C-80 100 MFD. CONDENSER
			C-81 47 MFD.
			C-82 100 MFD. CONDENSER
			C-83 47 MFD.
			C-84 100 MFD. CONDENSER
			C-85 47 MFD.
			C-86 100 MFD. CONDENSER
			C-87 47 MFD.
			C-88 100 MFD. CONDENSER
			C-89 47 MFD.
			C-90 100 MFD. CONDENSER
			C-91 47 MFD.
			C-92 100 MFD. CONDENSER
			C-93 47 MFD.
			C-94 100 MFD. CONDENSER
			C-95 47 MFD.
			C-96 100 MFD. CONDENSER
			C-97 47 MFD.
			C-98 100 MFD. CONDENSER
			C-99 47 MFD.
			C-100 100 MFD. CONDENSER

PART NO	DESCRIPTION
BPK-41	S 4" P.M. SPEAKER
	V-C VOICE COIL
	T-3 OUTPUT TRANSFORMER
LL-42	L-1 LOOP ANTENNA
LD-21	L-2 OSC. COIL
SO-54	SO APPLIANCE OUTLET SOCKET
SW-9	SW-1 RADIO ON-OFF SWITCH
CK-4	M ELECTRIC CLOCK
	SW-2
OL-9	DL DIAL LIGHT SOCKET
PB-1	PB 47 PILOT LIGHT BULB

Remove the chassis from the cabinet for alignment. A signal generator is required having the following frequencies: 455 KC, 540 KC, 600 KC, 1400 KC, 1610 KC. An output meter should be connected across the speaker.

**FIRST STEP:** Connect the hot lead from the generator to the RF. section of the gang condenser through a .1 MFD. condenser. The ground lead from the generator must be connected to "B" minus under the chassis. Turn the gang condenser to complete minimum capacity. Set the generator to 455 KC. Adjust the movable iron cores in the IF cans. The IF adjustments are made in the top and in the bottom of the cans. Adjust the cores until a maximum reading is noted on the output meter.

The volume control of the receiver should be turned to maximum during the IF and all subsequent alignment and the generator output as low as possible to prevent the AVC from working and giving false readings.

**SECOND STEP:** With the leads from the generator still connected as in IF alignment, adjust the generator to 1610 KC. Make sure that the gang condenser is turned to complete minimum capacity. Adjust the oscillator trimmer of the receiver until the signal is tuned in. Next, turn the gang condenser to complete maximum capacity. Adjust the generator to 540 KC., then adjust the iron core in the end

of the oscillator coil until the signal is tuned in. It may be well to recheck the 1610 KC. setting to make sure that the adjustment of the iron core has not shifted the frequency.

**THIRD STEP:** Remove the hot lead of the generator from the RF. section of the gang and connect this lead to the ANT. section of the gang. Set the generator to 1400 KC. Turn the gang condenser and tune in the signal. Adjust the RF. trimmer for maximum signal. Set the generator to 600 KC. and turn the gang condenser until the signal is tuned in. Adjust the iron core in the top of the RF. can until a maximum signal is noted. It may be well to re-check the 1400 KC. setting to make sure that the 600 KC. adjustment has not effected the 1400 KC. setting.

**FOURTH STEP:** Remove the generator leads from the gang condenser and the chassis. Loosely couple the generator to the antenna by laying the hot generator lead near the loop antenna. Set the generator at 1400 KC. and tune in the 1400 KC. signal on the receiver. Adjust the ANT. trimmer and RF. trimmer until a maximum signal is noted on the output meter.

No further adjustment should be necessary as the coils and gang condenser in this receiver have been specially handled at the factory to insure proper alignment at the lower frequencies.

# UNITED MOTORS Chevrolet Model 987573

(Continued on page 156, over)

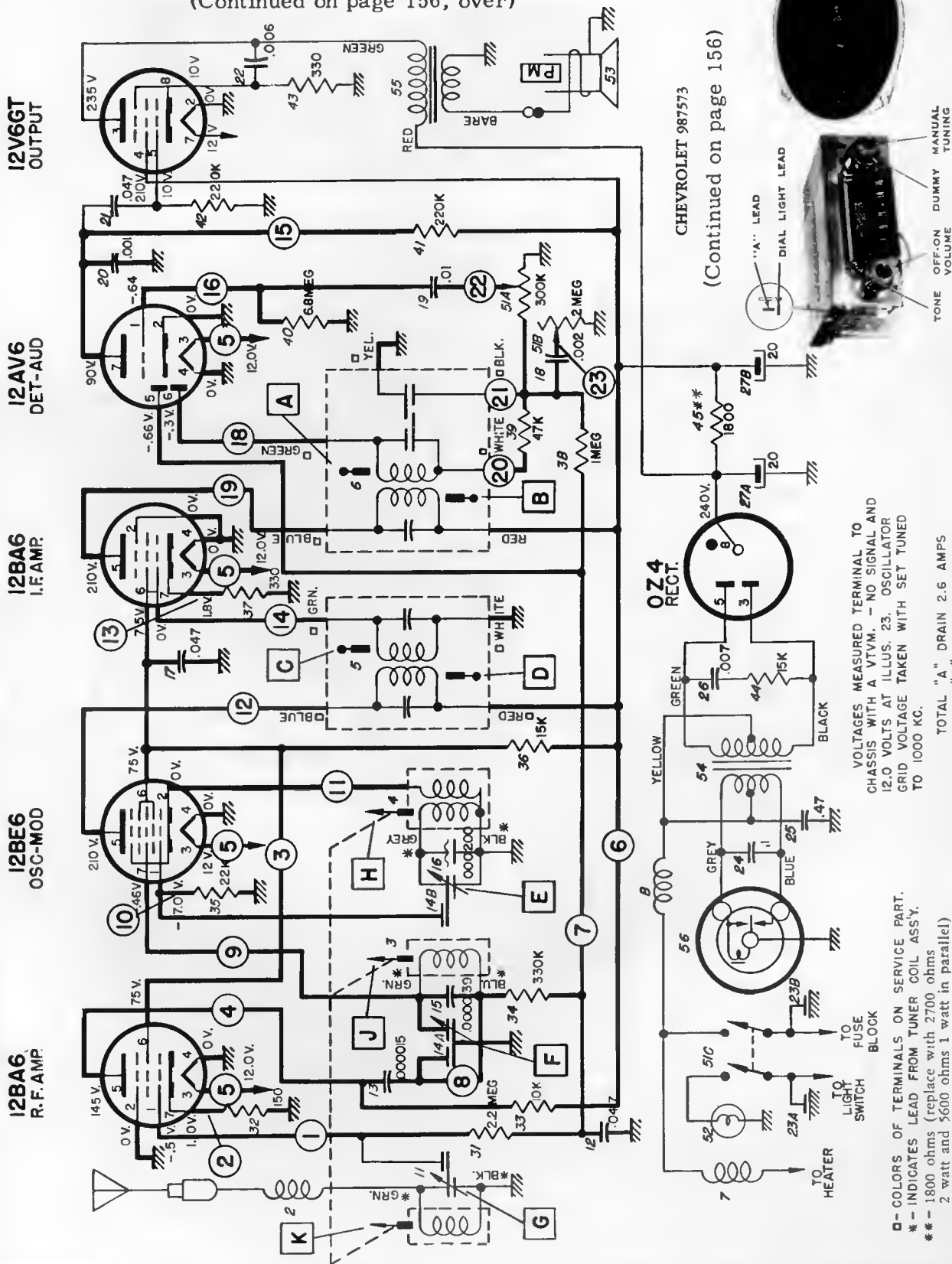

CHEVROLET 987573  
(Continued on page 156)

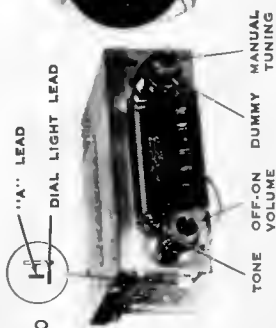

VOLTAGES MEASURED TERMINAL TO CHASSIS WITH A VTVM. - NO SIGNAL AND 12.0 VOLTS AT ILLUS. 23. OSCILLATOR GRID VOLTAGE TAKEN WITH SET TUNED TO 1000 KC.

TOTAL "A" DRAIN 2.6 AMPS  
TOTAL "B" DRAIN 52 MA.

□ - COLORS OF TERMINALS ON SERVICE PART.  
\* - INDICATES LEAD FROM TUNER COIL ASS'Y.  
\*\* - 1800 ohms (replace with 2700 ohms 2 watt and 5600 ohms 1 watt in parallel)

**UNITED MOTORS**

**Chevrolet Model 987573**  
(con't.)

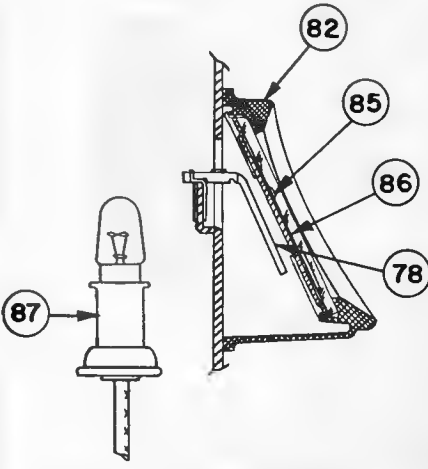

ESCUTCHEON CROSS SECTION

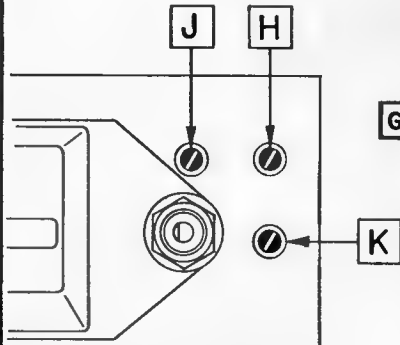

IRON CORE ALIGNMENT

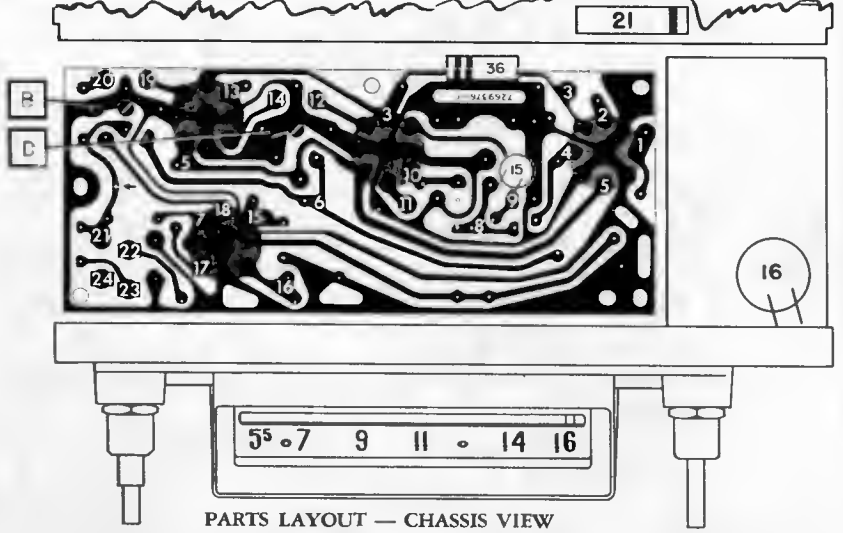

PARTS LAYOUT — CHASSIS VIEW

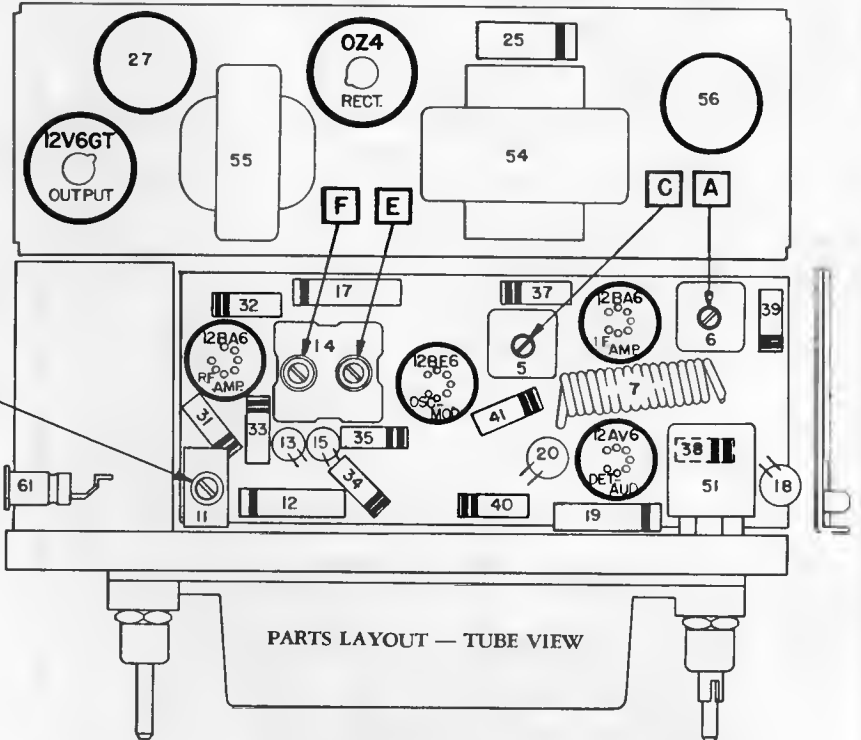

PARTS LAYOUT — TUBE VIEW

**ALIGNMENT**

Steps	Series Capacitor or Dummy Antenna	Connect Signal Generator to	Signal Generator Frequency	Tune Receiver to	Adjust in Sequence For Max. Output
1	0.1 Mfd.	12BE6 Grid (Pin #7)	262 KC	High Frequency Stop	A, B, C, D
2	0.000068 Mfd.	Antenna Connector	1615 KC	High Frequency Stop	*E, F, G
3	0.000068 Mfd.	Antenna Connector	600 KC	Signal Generator Signal	J, K
4	0.000068 Mfd.	Antenna Connector	1615 KC	High Frequency Stop	F, G
5	0.000068 Mfd.	Antenna Connector	900 KC	Signal Generator Signal	**

\*Before making this adjustment check mechanical setting of oscillator core "H." The rear of the core should be 1 1/8" from the mounting end of the coil form. (This measurement is readily made by inserting a suitable plug in the mounting end of the coil form.) Core adjustment should be made with a non-metallic screw driver.

\*\*Tune in 1100 KC signal and adjust pointer on the dial cord so that the pointer is on the 1100 KC mark of the dial. This setting is to give the correct relationship between the pointer and dial when the radio is installed in a car.

With the radio installed and the car antenna plugged in adjust the antenna trimmer "G" for maximum volume with the radio tuned to a weak station between 600 and 1000 KC (see sticker on case.)

UNITED MOTORS

Chevrolet Pushbutton Model 987575

(Continued on page 158, over)

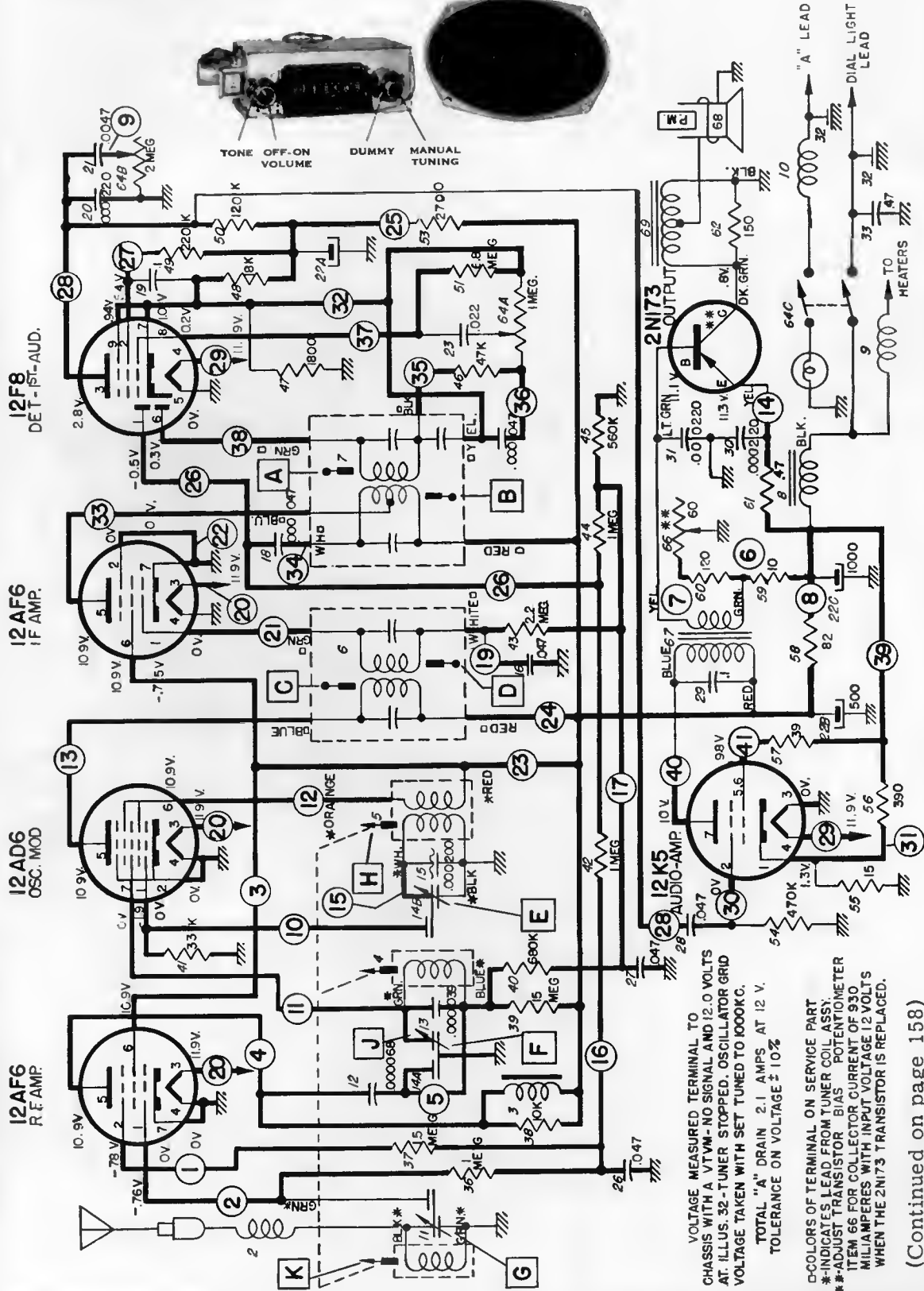
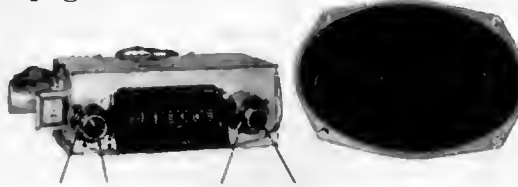

VOLTAGE MEASURED TERMINAL TO CHASSIS WITH A VTVM - NO SIGNAL AND 12.0 VOLTS AT ILLUS. 32 - TUNER STOPPED, OSCILLATOR GRID VOLTAGE TAKEN WITH SET TUNED TO 1000KC.  
TOTAL "A" DRAIN 2.1 AMPS. AT 12 V.  
TOLERANCE ON VOLTAGE ± 10%

COLOURS OF TERMINAL ON SERVICE PART \*INDICATES LEAD FROM TUNER COIL ASSY. \*\*ADJUST TRANSISTOR BIAS POTENTIOMETER ITEM 66 FOR COLLECTOR CURRENT OF 930 MILLIAMPERES WITH INPUT VOLTAGE 12 VOLTS WHEN THE 2N173 TRANSISTOR IS REPLACED.

(Continued on page 158)

RADIO BLOWS FUSES

If the radio blows fuses, check for a shorted transistor. If the transistor is O.K., check for a short in the radio A supply circuit.

Signal trace, using isolated (capacitor in lead) signal generator or "signal tracer." A strong audio signal injected at the 12K5 tube plate, pin #7, should be heard in the case of a dead radio. (A quick check of the audio stage can be made with the radio warmed up by pulling out the 12K5 tube and listening for a "click". If the "click" is heard the transistor stage is working.)

UNITED MOTORS Chevrolet 987575 (Continued from page 157)

TROUBLE SHOOTING THE OUTPUT STAGE

A quick way to determine that the 2N173 is conducting can be made by checking the collector voltage, from transistor case to the radio case. If no voltage is present the transistor is not conducting or the transistor heat radiator is grounded to the radio case. If the voltage at the collector is higher than listed the transistor is conducting too heavily (check with milliammeter) or the output transformer is open. The amount of current the transistor conducts is determined by the voltages at each element, the resistor in the base and emitter circuits, the input transformer secondary resistance, and the transistor itself. The most common defect in the transistor is an internal

short between emitter and collector. To check for this, use the following procedure:

1. Unsolder base and emitter leads from the circuit.
2. Set ohmmeter on the "R x 1" scale (no other scale should be used).
3. Place negative lead of ohmmeter (polarity refers to internal ohmmeter battery) on collector, and positive lead on the emitter.
4. The transistor is shorted if reading is "O".

If a transistor is replaced, the "bias" adjustment should be made for the new transistor. Insert a milliammeter in the collector lead and adjust the bias control for a collector current of 930 ma.

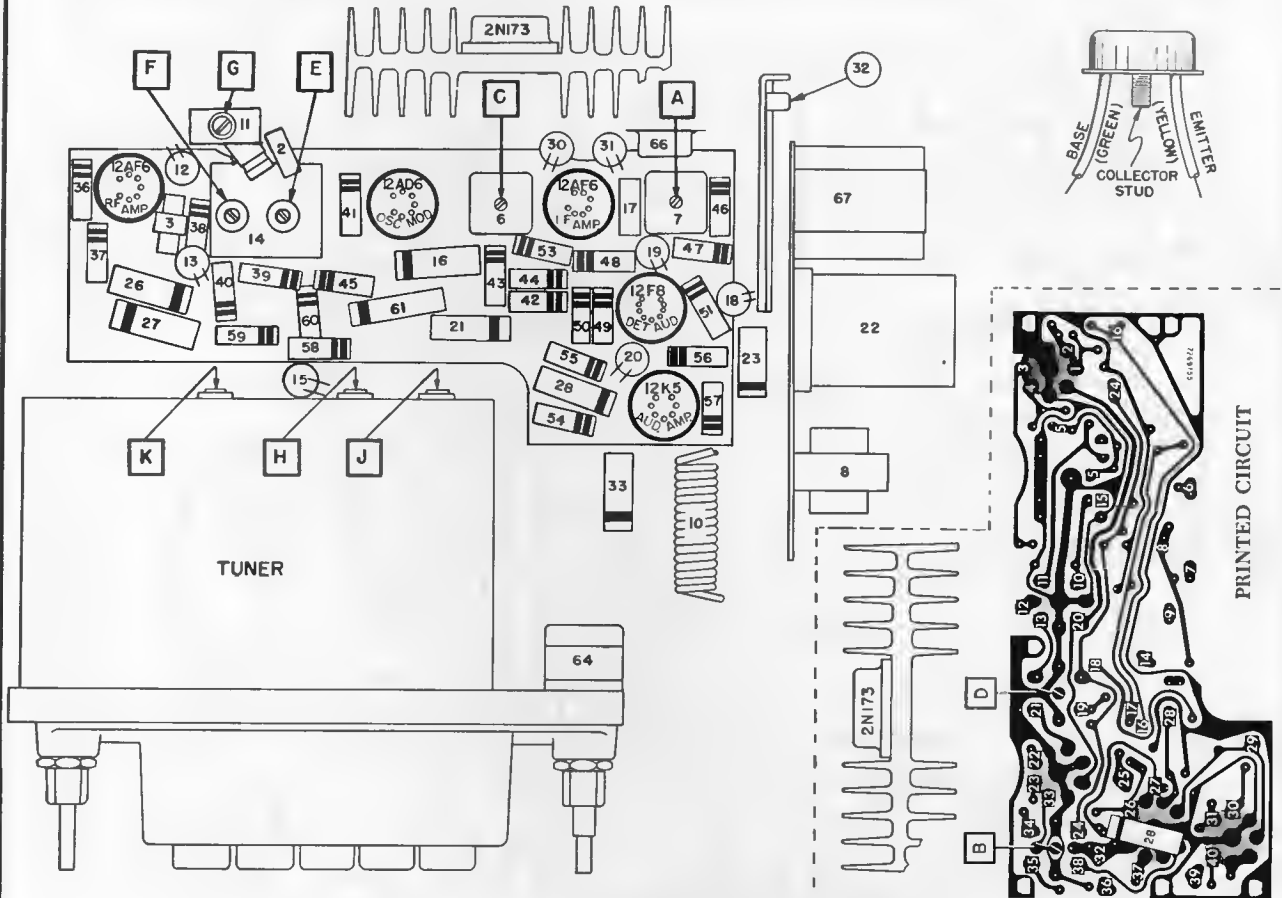

PARTS LAYOUT—TUBE VIEW

ALIGNMENT PROCEDURE

Steps	Series Capacitor or Dummy Antenna	Connect Signal Generator to	Signal Generator Frequency	Tune Receiver to	Adjust in Sequence For Max. Output
1	0.1 Mfd.	12AD6 Grid (Pin #7)	262 KC	High Frequency Stop	A, B, C, D
2	0.000068 Mfd.	Antenna Connector	1615 KC	High Frequency Stop	*E, F, G
3	0.000068 Mfd.	Antenna Connector	640 KC	Signal Generator Signal	J, K
4	0.000068 Mfd.	Antenna Connector	1615 KC	High Frequency Stop	F, G
5	0.000068 Mfd.	Antenna Connector	900 KC	Signal Generator Signal	L**

\*Before making this adjustment check mechanical setting of oscillator core "H." The rear of the core should be 1 5/8" from the mounting end of the coil form. (This measurement is readily made by inserting a suitable plug in the mounting end of the coil form.) Core adjustment should be made with a non-metallic screw driver.

\*\*L is the pointer adjustment which is on the connecting link, between the pointer assembly and core guide bar.

It should be adjusted so that when looking directly at the dial the pointer is on the 1100 KC mark. This setting is to give the correct relationship between the pointer and the dial when the radio is installed in a car.

With the radio installed and the car antenna plugged in adjust the antenna trimmer "G" for maximum volume with the radio tuned to a weak station between 600 and 1000 KC (see sticker on case.)

UNITED MOTORS - CHEVROLET MODEL 987693

(Continued on page 160, over)

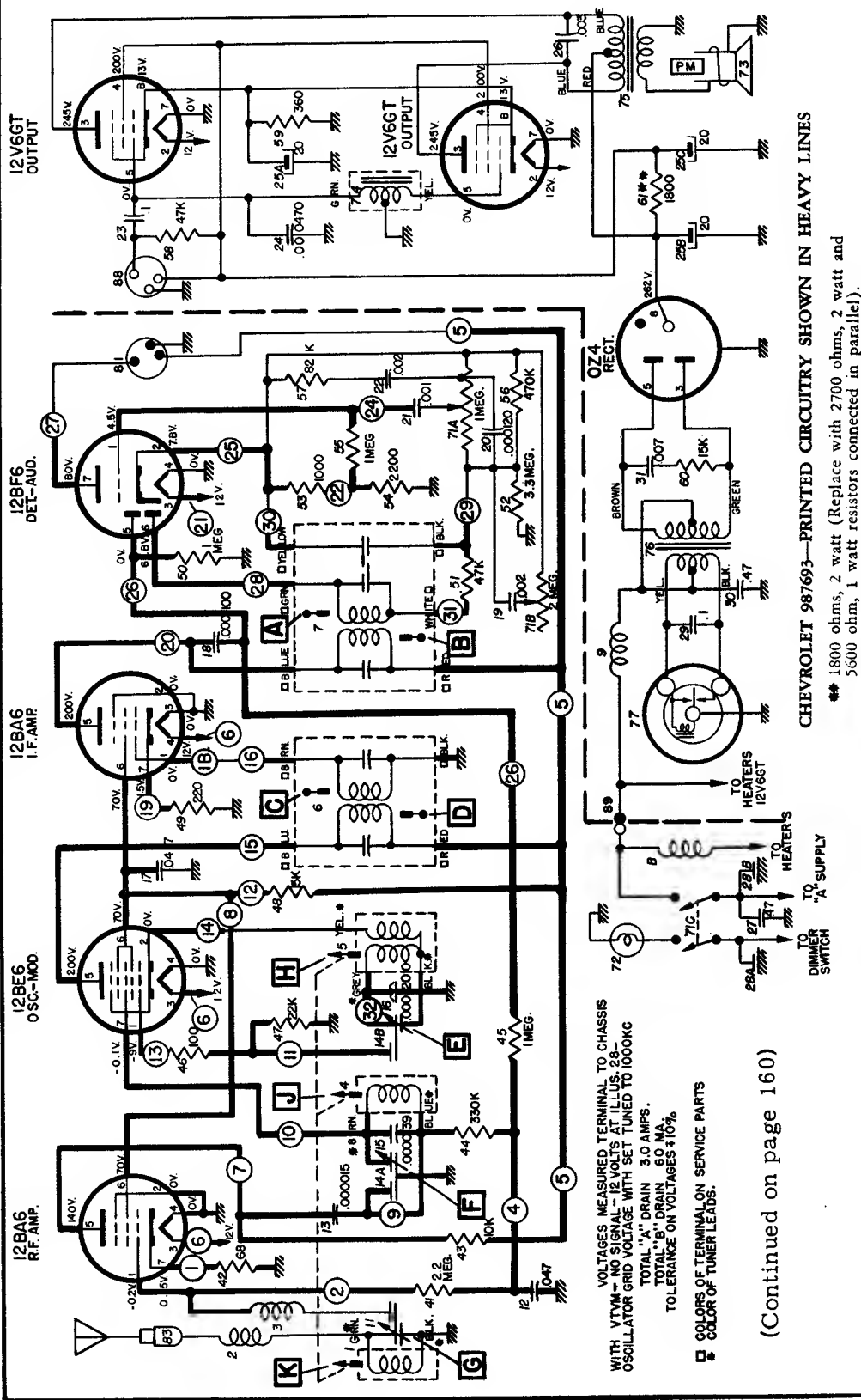

CHEVROLET 987693—PRINTED CIRCUITRY SHOWN IN HEAVY LINES

\*\* 1800 ohms, 2 watt (Replace with 2700 ohms, 2 watt and 5600 ohm, 1 watt resistors connected in parallel).

VOLTAGES MEASURED TERMINAL TO CHASSIS  
 WITH VTVM—NO SIGNAL—12 VOLTS AT ILLUS. 28—  
 OSCILLATOR GRID VOLTAGE WITH SET TUNED TO 1000 KC.  
 TOTAL "A" DRAIN 3.0 AMPS.  
 TOTAL "B" DRAIN 60 MA.  
 TOLERANCE ON VOLTAGES ±10%  
 TOLERANCE ON VOLTAGES ±10%  
 COLOR OF TUNER LEADS.

(Continued on page 160)

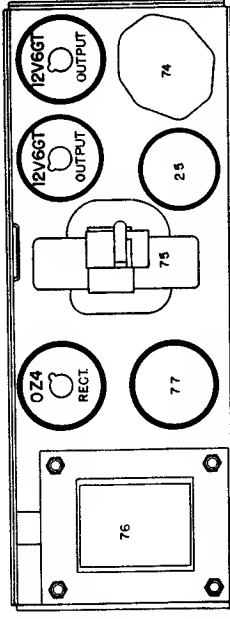

PARTS LAYOUT—TUBE VIEW (POWER SUPPLY)

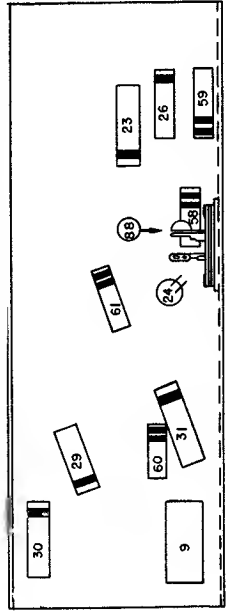

PARTS LAYOUT—CHASSIS VIEW (POWER SUPPLY)

ANTENNA TRIMMER COMPENSATION—For Antennas Between 0.000050 - 0.000090 Mfd.  
 TUNING RANGE—540-1600 KC.

PUSH BUTTON SETUP PROCEDURE  
 Pull Push Button to the left and out. Tune in desired station manually. Push button all the way in.

UNITED MOTORS Chevrolet 987693

(Continued from page 159)

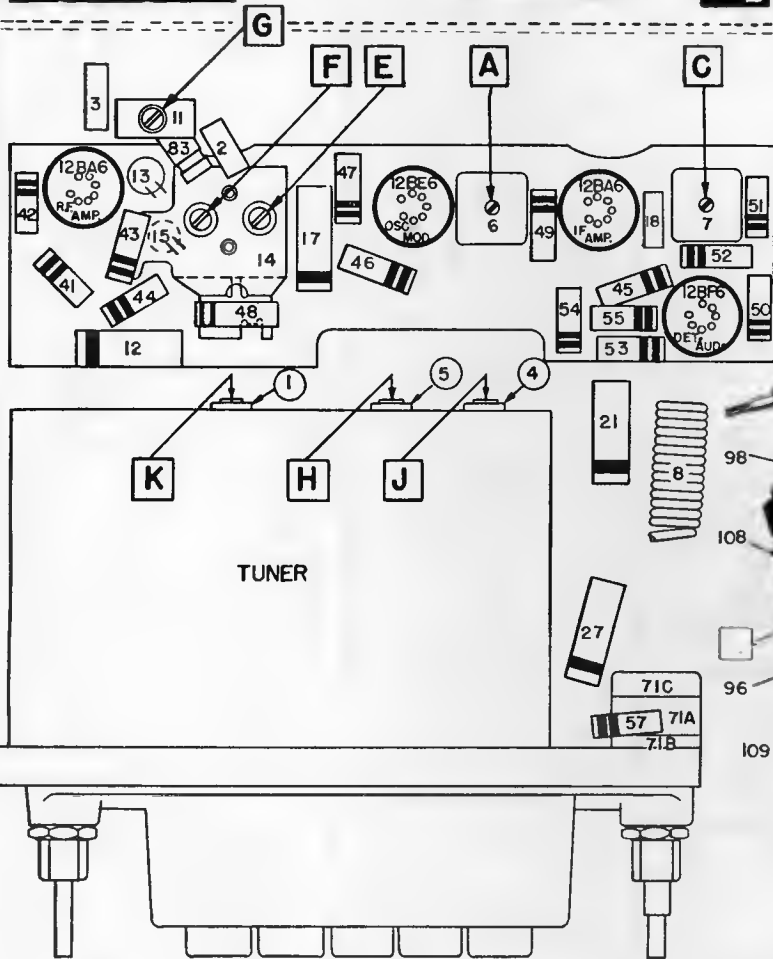
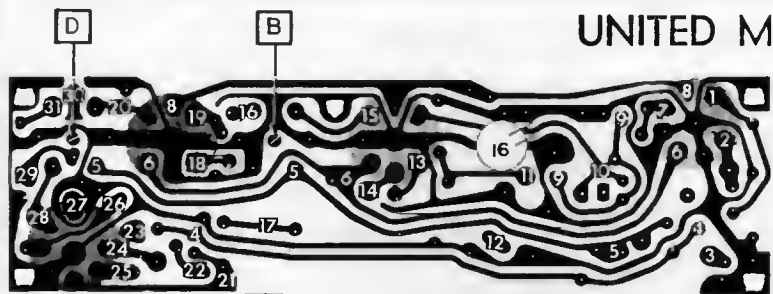

PARTS LAYOUT—TUBE VIEW

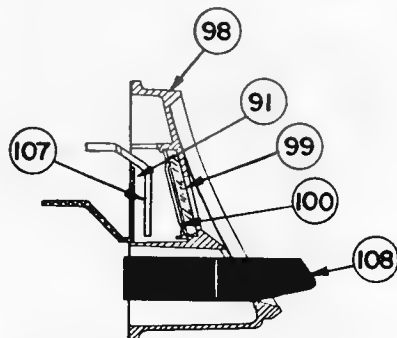

ESCUTCHEON CROSS SECTION

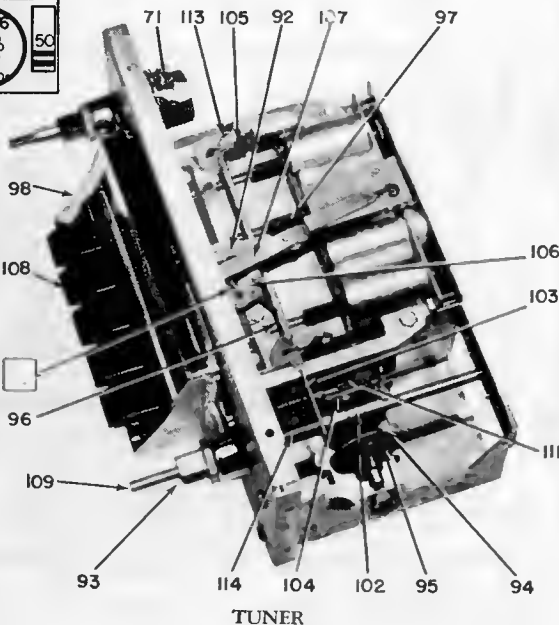

TUNER

ALIGNMENT PROCEDURE

Steps	Series Capacitor or Dummy Antenna	Connect Signal Generator to	Signal Generator Frequency	Tune Receiver to	Adjust in Sequence For Max. Output
1	0.1 Mfd.	12BE6 Grid (Pin #7)	262 KC	High Frequency Stop	A, B, C, D
2	0.000068 Mfd.	Antenna Connector	1615 KC	High Frequency Stop	*E, F, G
3	0.000068 Mfd.	Antenna Connector	600 KC	Signal Generator Signal	J, K
4	0.000068 Mfd.	Antenna Connector	1615 KC	High Frequency Stop	F, G
5	0.000068 Mfd.	Antenna Connector	900 KC	Signal Generator Signal	L**

\*Before making this adjustment check mechanical setting of oscillator core "H." The rear of the core should be 1 1/2" from the mounting end of the coil form. (This measurement is readily made by inserting a suitable plug in the mounting end of the coil form.) Core adjustment should be made with a non-metallic screw driver.

\*\*L is the pointer adjustment screw which is on the connecting link, between the pointer assembly and core guide bar (See tuner Dwg.). It should be adjusted so that when looking directly at the dial the pointer is on the 1000 KC mark. This setting is to give the correct relationship between the pointer and the dial when the radio is installed in a car. With the radio installed and the car antenna plugged in adjust the antenna trimmer "G" for maximum volume with the radio tuned to a weak station between 600 and 1000 KC (see sticker on case.)



# UNITED MOTORS 12V PONTIAC MODEL 988623

(Continued on page 162, over)

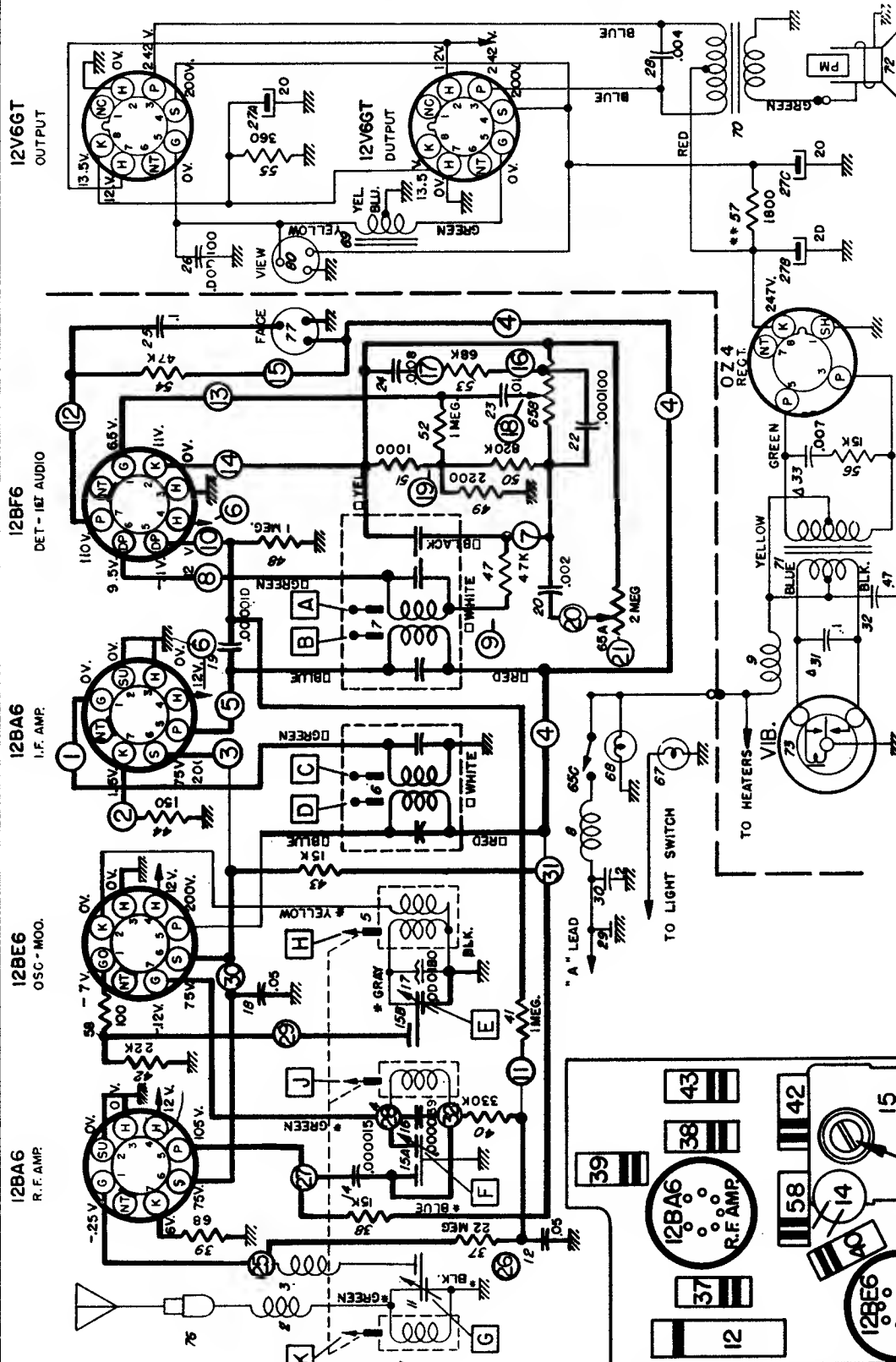

□ - COLORS OF TERMINALS ON SERVICE PARTS

- \* - INDICATES LEADS FROM TUNER COIL ASS'Y
- \* - 1800 Ohms (Replace with 2700 ohms, 2 Watt and 5600 Ohms, 1 Watt in parallel)
- Δ - SOME RADIOS HAVE ILLUSTRATION 31 OMITTED AND USE A .006 MFD. BUFFER (ILLUST. 33)
- K - INDICATES THOUSAND FOR RESISTOR VALUES.

TUBE SOCKETS SHOWN FROM TERMINAL VIEW, VOLTAGES MEASURED TERMINAL TO CHASSIS WITH A VTVM. NO SIGNAL AND 12.0 VOLTS AT ILLUS. 29, OSCILLATOR GRID VOLTAGE TAKEN WITH SET TUNED TO 1000 KC

TOTAL "A" DRAIN 3.3 AMP.  
 TOTAL "B" DRAIN 65 MA.  
 TOLERANCE ON VOLTAGES ± 10%

UNITED MOTORS PONTIAC MODEL 988623

(Continued)

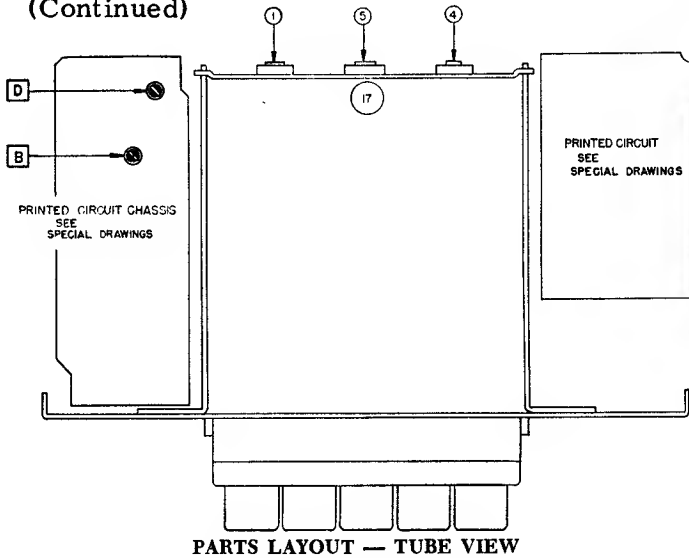

PARTS LAYOUT — TUBE VIEW

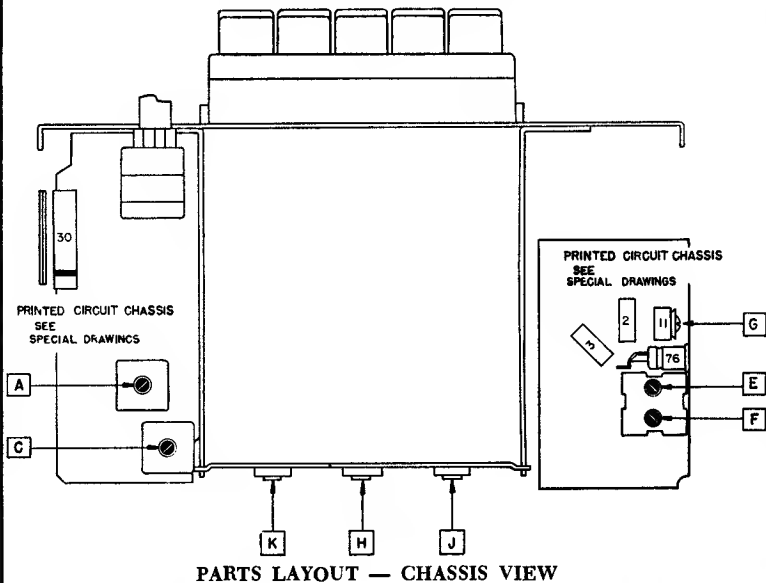

PARTS LAYOUT — CHASSIS VIEW

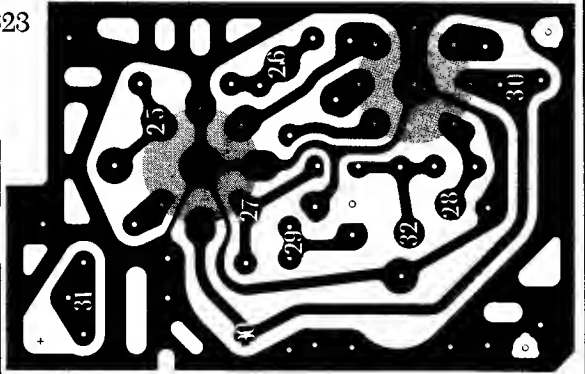

PRINTED CIRCUIT CHASSIS  
OSC. - MOD.  
and  
R. F. STAGE

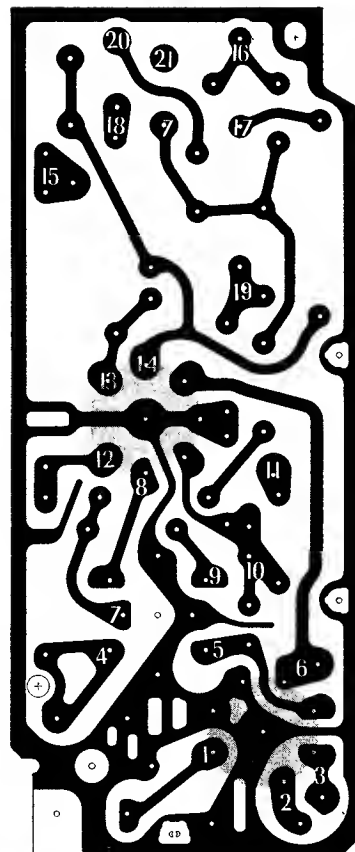

PRINTED CIRCUIT CHASSIS  
Detector—1st Audio  
and  
I.F. Stage

Steps	Series Capacitor or Dummy Antenna	Connect Signal Generator to	Signal Generator Frequency	Tune Receiver to	Adjust in Sequence For Max. Output
1	0.1 Mfd.	12BE6 Grid (Pin #7)	262 KC	High Frequency Stop	A, B, C, D
2	0.000082 Mfd.	Antenna Connector	1615 KC	High Frequency Stop	*E, F, G
3	0.000082 Mfd.	Antenna Connector	1000 KC	Signal Generator Signal	J, K
4	0.000082 Mfd.	Antenna Connector	1615 KC	High Frequency Stop	F, G
5	0.000082 Mfd.	Antenna Connector	900 KC	Signal Generator Signal	Illus. # 79**

\*Before making this adjustment check mechanical setting of oscillator core "H." The rear of the core should be 1 3/32" from the mounting end of the coil form. (This measurement is readily made by inserting a suitable plug in the mounting end of the coil form.) Core adjustment should be made with an insulated screw driver.

\*\*Illus. # 79 is the pointer adjustment screw which is on the connecting link, between the pointer assembly and core guide bar. It should be adjusted so that when looking directly at the dial the pointer is on the 900 KC mark. This setting is to give the correct relationship between the pointer and the dial when the radio is installed in a car.

With the radio installed and the car antenna plugged in adjust the antenna trimmer "G" for maximum volume with the radio tuned to a weak station between 600 and 1000 KC (see sticker on case.)

# Westinghouse

Models H-574T4, H-575T4, H-576T4, H-577T4,  
Using Chassis Assembly V-2239-2

## ALIGNMENT

While making the following adjustments, keep the volume control set for maximum output and the signal generator output attenuated to weakest useable signal level.

Step	Connect Signal Generator to -	Signal Generator Frequency	Radio Dial	Connect V.T.V.M. Across Voice Coil and Adjust for Maximum Output -
1	Stator of ant. tuning capacitor (A) through a 200 mmf capacitor	455 kc.	minimum capacity	Top and bottom slugs of T2 and T1 in order given
2	Radiated signal	1625 kc.	minimum capacity	Oscillator trimmer (D)
3	Radiated signal	1400 kc.	1400 kc.	Antenna trimmer (B)

- NOTE:  
1. ALL CAPACITANCE VALUES IN MFD AND ALL RESISTANCE VALUES IN OHMS UNLESS OTHERWISE STATED.  
2. ALL VOLTAGES MEASURED FROM B - USING A V.T.V.M. - LINE VOLTAGE SET AT 117 V A.C. READINGS SHOULD BE AS SHOWN  $\pm 20\%$ .  
3. CHASSIS GROUND  $\text{---}$   
COMMON B -  $\text{---}$

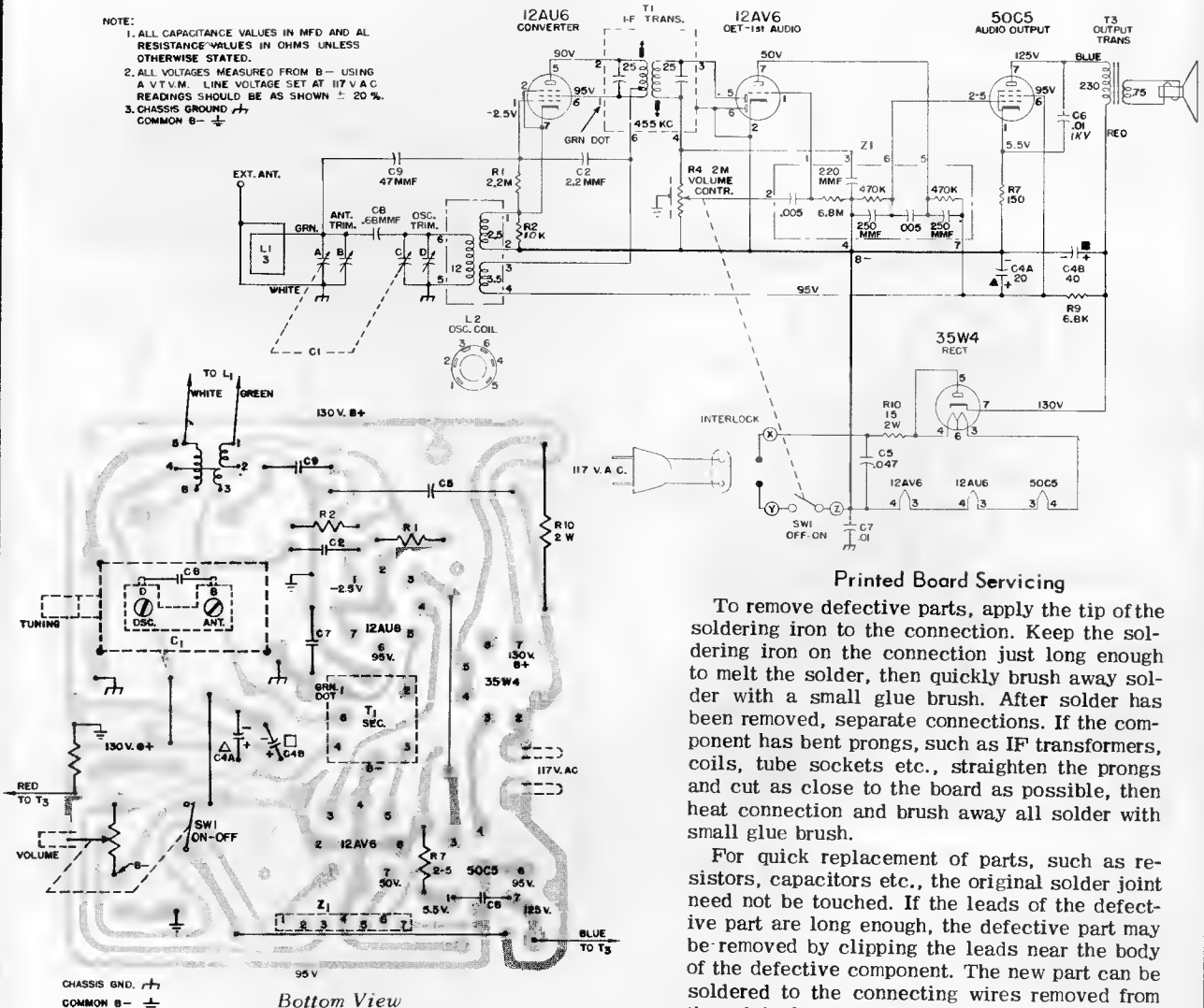

### Printed Board Servicing

To remove defective parts, apply the tip of the soldering iron to the connection. Keep the soldering iron on the connection just long enough to melt the solder, then quickly brush away solder with a small glue brush. After solder has been removed, separate connections. If the component has bent prongs, such as IF transformers, coils, tube sockets etc., straighten the prongs and cut as close to the board as possible, then heat connection and brush away all solder with small glue brush.

For quick replacement of parts, such as resistors, capacitors etc., the original solder joint need not be touched. If the leads of the defective part are long enough, the defective part may be removed by clipping the leads near the body of the defective component. The new part can be soldered to the connecting wires removed from the original part.

The printed board is held secure in the cabinet by a top and bottom channel molded into the cabinet. Located above the tuning shaft and concealed by the tuning knob is a single screw (No. 6/32-5/8") which mounts the printed board to the front of the cabinet.

To remove the printed board from the cabinet, remove the front control knobs then remove the screw mounting the printed board to the front of the cabinet. Remove the two self-tapping screws, interlock and back cover. The printed board can now be removed from the cabinet.

# Westinghouse

Models H-499T5B, H-500T5B, H-501T5B,  
H-503T5B, H-551T5B, Chassis V-2259-2

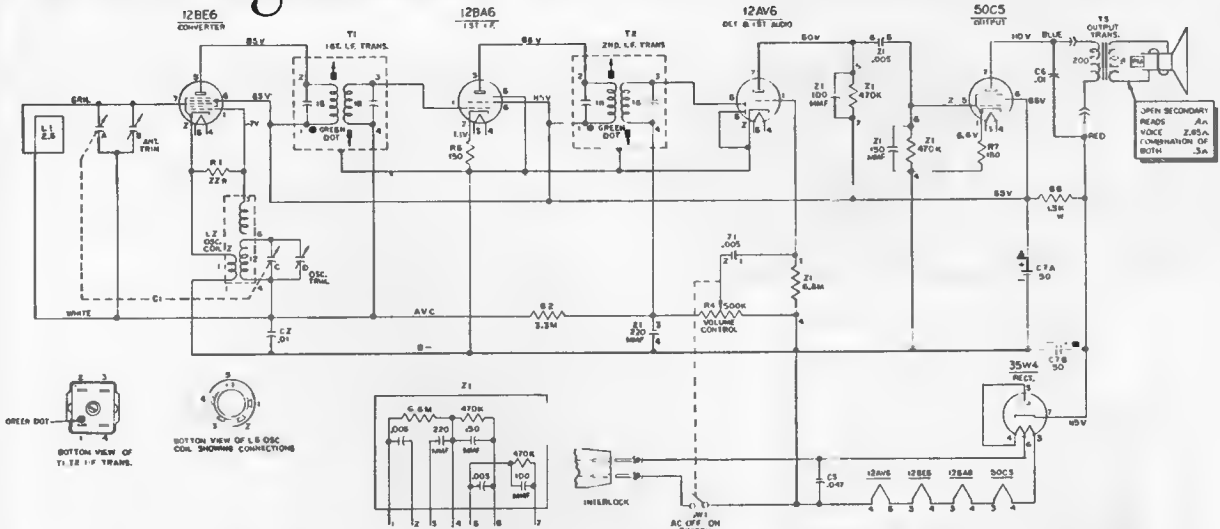

**NOTES:**  
 1. ALL VOLTAGES MEASURED FROM COMMON NEGATIVE LEAD. ALL VOLTAGE MEASUREMENTS AT NOMINAL TUNING CAPACITANCE AT MAXIMUM LINE VOLTAGE. SET AS BY AC METER SHOULD BE AS WITHIN ±.20 PLS LEVEL.  
 2. ALL CAPACITANCE VALUES IN MFD, AND ALL RES. AND V. VALUES IN OHMS UNLESS OTHERWISE SPECIFIED.

### CHASSIS REMOVAL INFORMATION

1. Remove the off-on-volume knob from the front of the cabinet.
2. Remove the back cover from the cabinet.
3. Remove the 1/4" self-tapping screw securing the capacitor bracket to the front of the cabinet.

**NOTE:** Do not attempt to remove tuning knob from the front of the cabinet. Tuning Capacitor Shaft will pull free of the tuning knob when the chassis is removed from the rear of the cabinet.

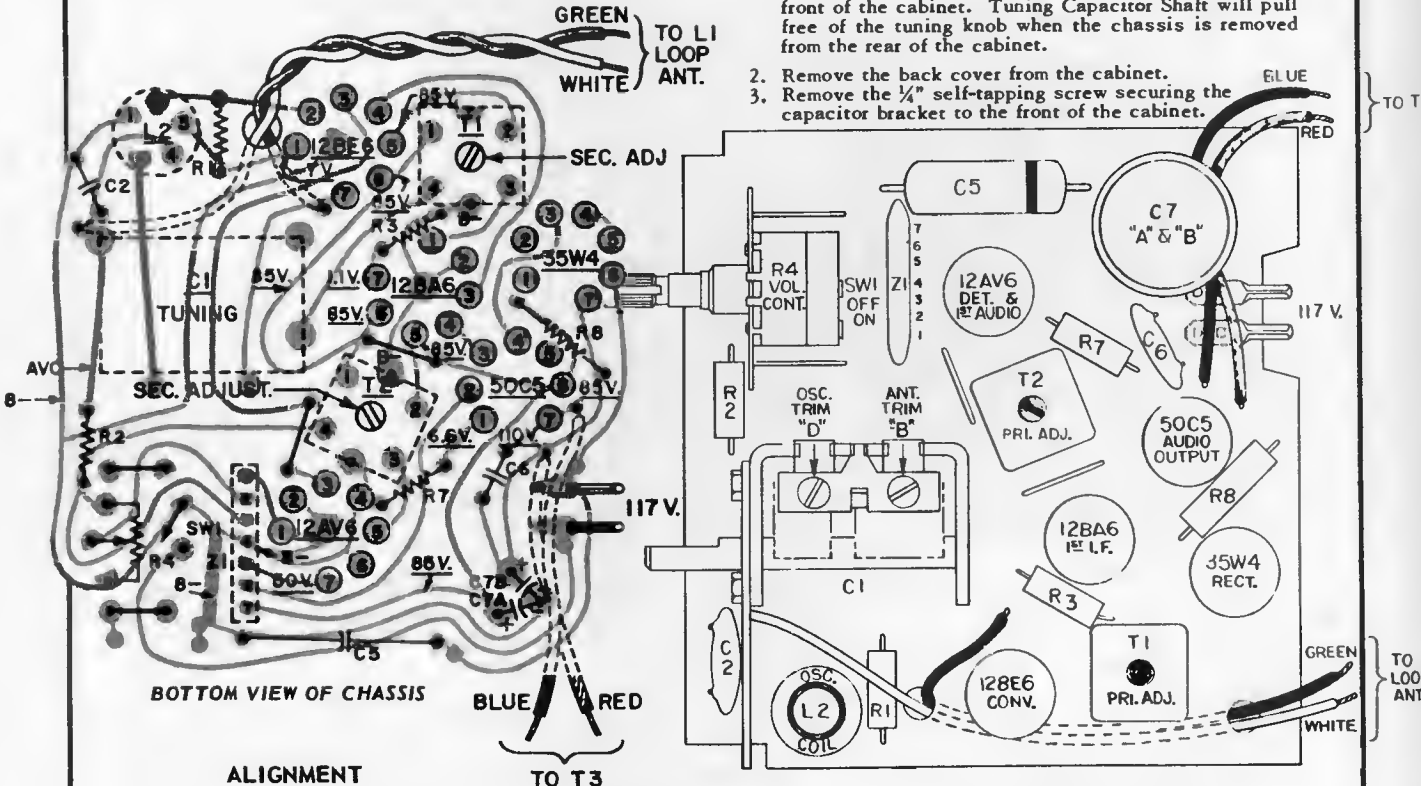

### ALIGNMENT

Step	Connect Signal Generator to -	Signal Generator Frequency	Radio Dial	Connect V.T.V.M. Across Voice Coil and Adjust for Maximum Output -
1.	Stator of ant. tuning capacitor (A) through a .01 mfd capacitor	455 kc.	Minimum capacity	Top and bottom slugs of T2 and T1 in order given
2.	Same as step 1	1625 kc.	Minimum capacity	Oscillator trimmer (D)
3.	Radiated signal	1400 kc.	1400 kc.	Antenna trimmer (B)

# Westinghouse

Models H-562P4, -A, H-563P4, -A, H-564P4, -A, and H-565P4, Using Chassis V-2268-1, -2, -3, -4

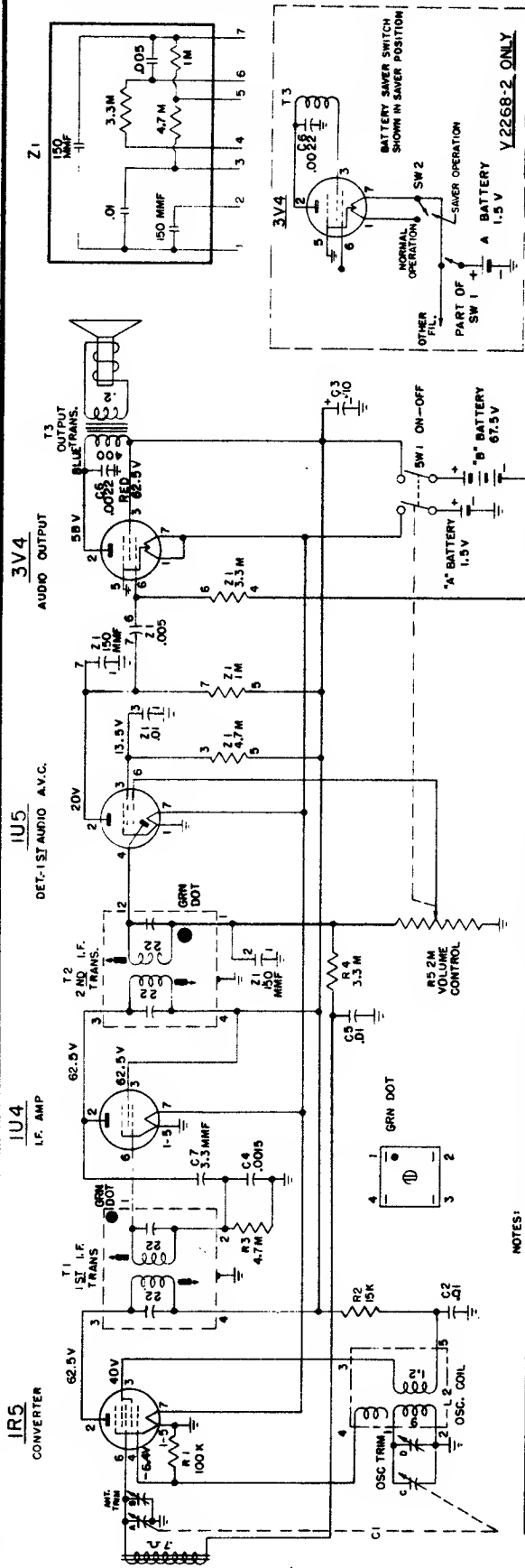

NOTES:  
 1 ALL CAPACITANCE VALUES IN MFD. AND ALL RESISTANCE VALUES IN OHMS UNLESS OTHERWISE SPECIFIED.  
 2 ALL VOLTAGES MEASURED FROM CHASSIS (GND) USING A V.T.M. VOLUME CONTR. AT MINIMUM TUNING OFF STATION, READINGS SHOULD BE AS SHOWN ± 20 PER CENT.

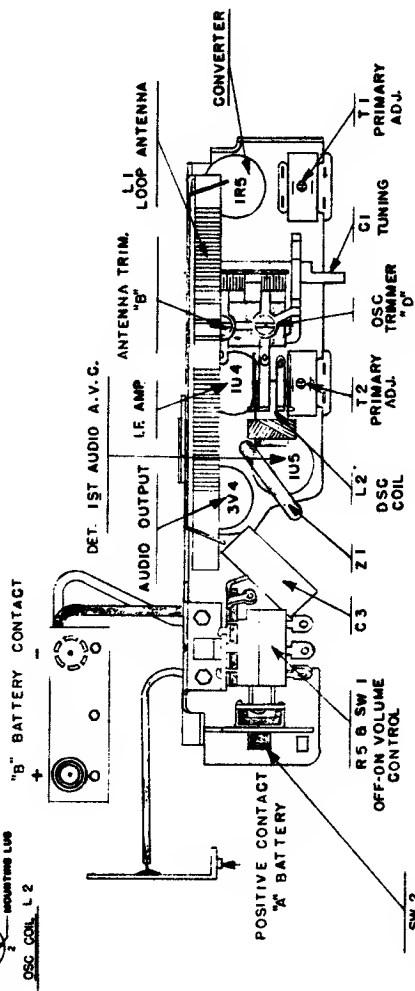

BOTTOM VIEW V2268-1-2

### ALIGNMENT

While making the following adjustments, keep the volume control set for maximum output and the signal generator output attenuated to avoid AVC act. Align in "normal" position of battery saver switch.

Step	Connect Signal Generator	Signal Generator Frequency Mod. 400 Cycles	Radio Dial	Connect VTVM Across Voice Coil and Adjust for Maximum Output.
1	Between Stator of R-F tuning capacitor (A) and (B), through a .01 mfd. capacitor and low side to ground.	455 kc.	minimum capacity	Top end bottom slugs in 2nd and 1st I-F trans. in order given.
2	Radiated Signal	1625 kc.	minimum capacity	Osc. trimmer (D)
3	Radiated Signal	1400 kc.	1400 kc.	Ant. trimmer (B)

\*It is recommended that a fiber aligning tool that snugly fits the slot in the powdered iron core be used to prevent chipping of the slot.

# Westinghouse

Models H-557P4, H-558P4, H-559P4, H-598P4, and H-599P4, using Chassis V-2271-1

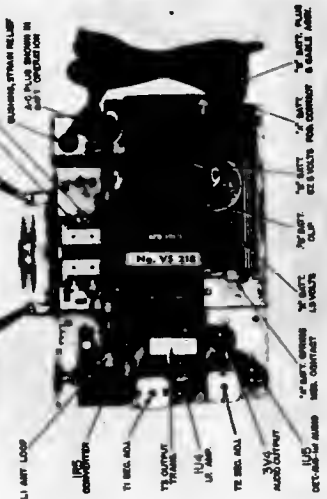
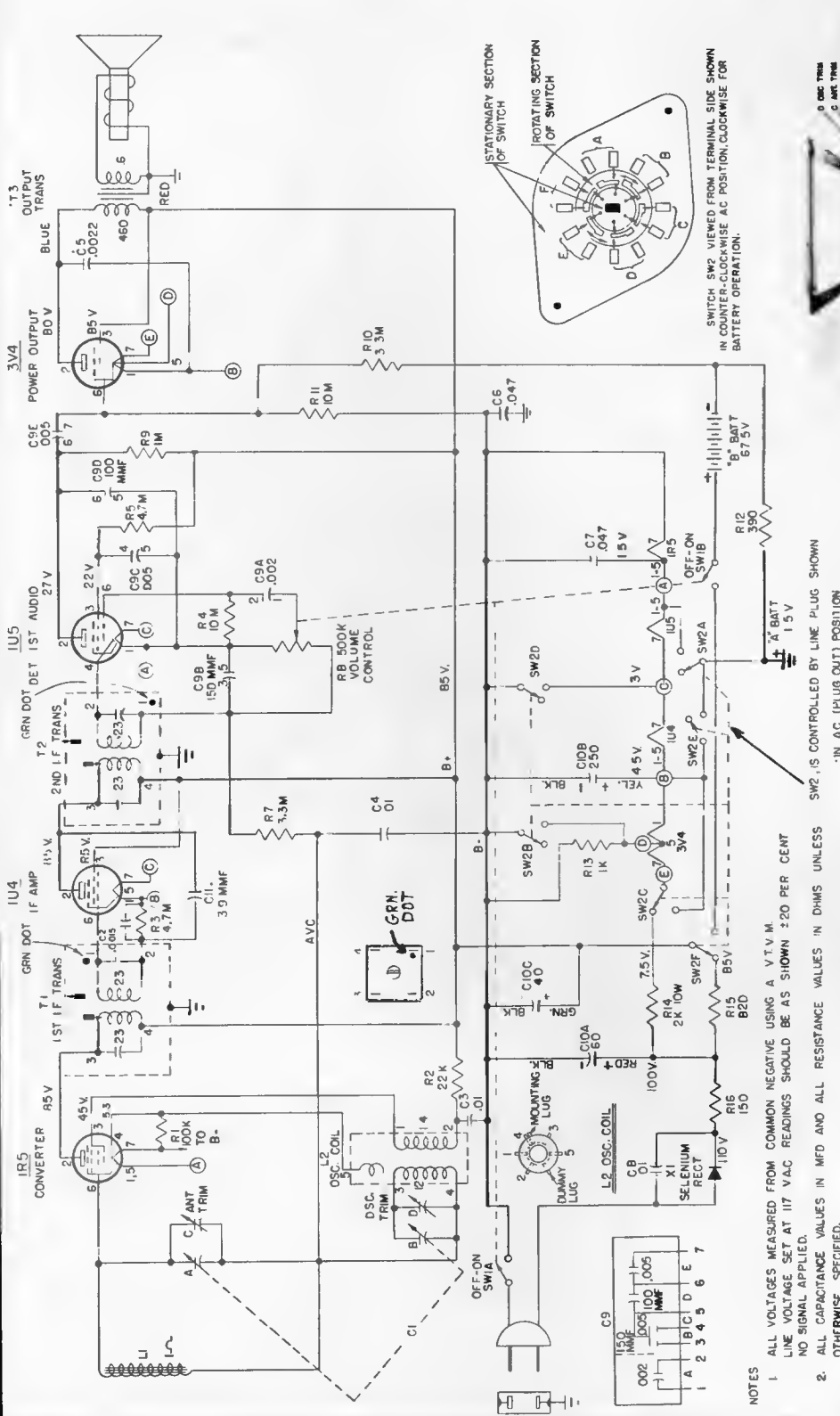

SWITCH SW2 VIEWED FROM TERMINAL SIDE SHOWN IN COUNTER-CLOCKWISE AC POSITION, CLOCKWISE FOR BATTERY OPERATION.

IN AC (PLUG OUT) POSITION

NOTES

1. ALL VOLTAGES MEASURED FROM COMMON NEGATIVE USING A V.T.V.M. LINE VOLTAGE SET AT 117 VAC. READINGS SHOULD BE AS SHOWN  $\pm 20$  PER CENT NO SIGNAL APPLIED.
2. ALL CAPACITANCE VALUES IN MFD AND ALL RESISTANCE VALUES IN OHMS UNLESS OTHERWISE SPECIFIED.

## ALIGNMENT

Step	Connect Signal Generator to	Signal Generator Frequency	Set Tuning Gang to	With VTVM Across The Voice Coil Adjust for Maximum Output
1	Stator of R-F tuning capacitor (A), through a .01 mfd. capacitor with low side to R -	455 kc.	Minimum capacity	Top and bottom slugs in 2nd and 1st I-F trans. in order given
2	Radiated Signal	1625 kc.	Minimum capacity	Osc. trimmer (D)
3	Radiated Signal	1400 kc.	1400 kc.	Ant. trimmer (C)

Westinghouse  
Chassis V-2278-1

MODELS

H-587P7

(Grey)

H-588P7

(Black)

H-589P7

(Red)

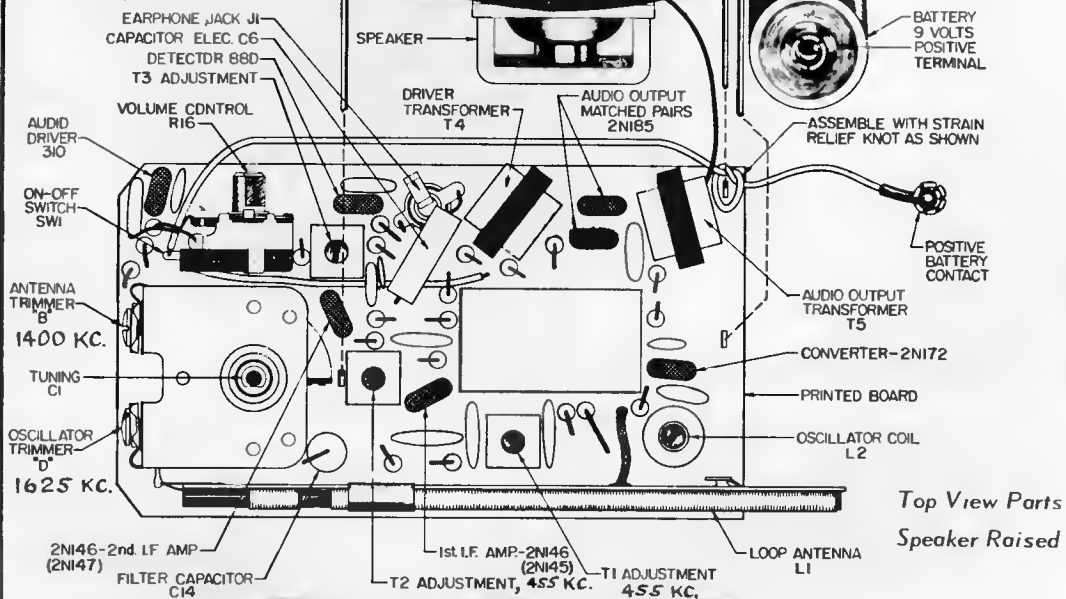
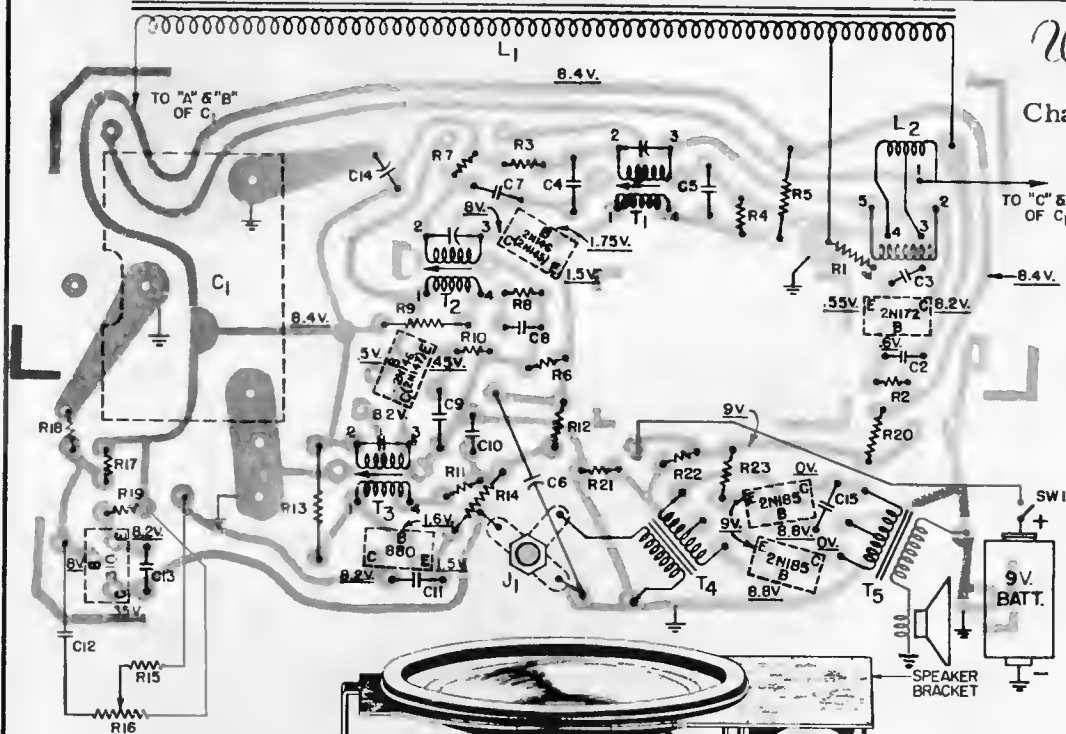

NO.	TYPE	FUNCTION
2N172	PNP	CONVERTER
2N145	PNP	1 <sup>st</sup> LF. AMPLIFIER
2N146	PNP	1 <sup>st</sup> LF. AMPLIFIER
2N147	PNP	1 <sup>st</sup> LF. AMPLIFIER
880	PNP	DETECTOR
3N0	PNP	AUDIO DRIVER
2N185	PNP	AUDIO OUTPUT

JUNCTION TRANSISTORS

Top View Parts Layout with  
Speaker Raised from Board

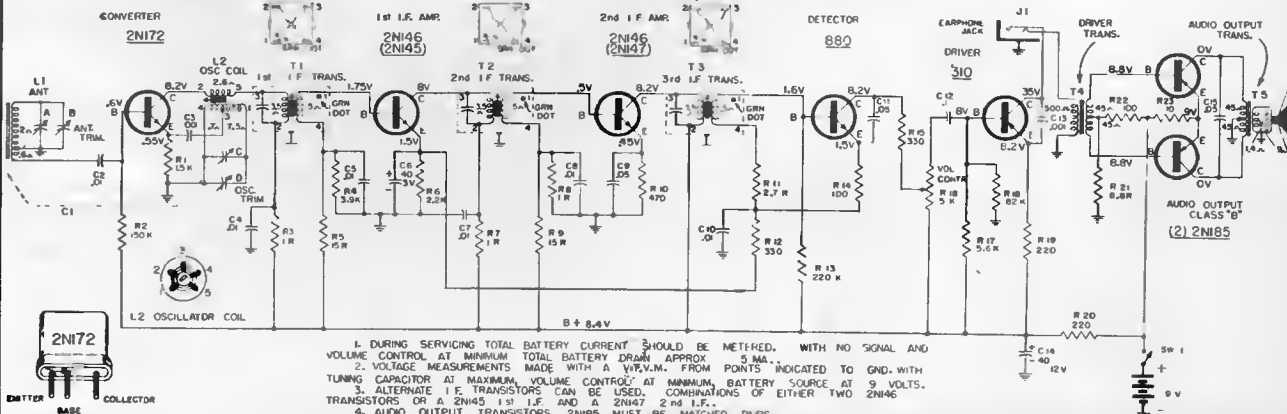

1. DURING SERVICING TOTAL BATTERY CURRENT SHOULD BE MEASURED. WITH NO SIGNAL AND VOLUME CONTROL AT MINIMUM TOTAL BATTERY DRAIN APPROX 5 MA.  
 2. VOLTAGE MEASUREMENTS MADE WITH A V.P.M. FROM POINTS INDICATED TO GND. WITH TUNING CAPACITOR AT MAXIMUM VOLUME CONTROL AT MINIMUM BATTERY SOURCE AT 9 VOLTS.  
 3. ALTERNATE 1<sup>st</sup> LF TRANSISTORS CAN BE USED. COMBINATIONS OF EITHER TWO 2N146 TRANSISTORS OR A 2N145 1<sup>st</sup> LF AND A 2N147 2<sup>nd</sup> LF.  
 4. AUDIO OUTPUT TRANSISTORS 2N185 MUST BE MATCHED PAIRS.

# Westinghouse

Chassis V-2278-2, used in  
Models H-610P5, H-611P5, H-612P5

(See the next page at right  
for additional service data)

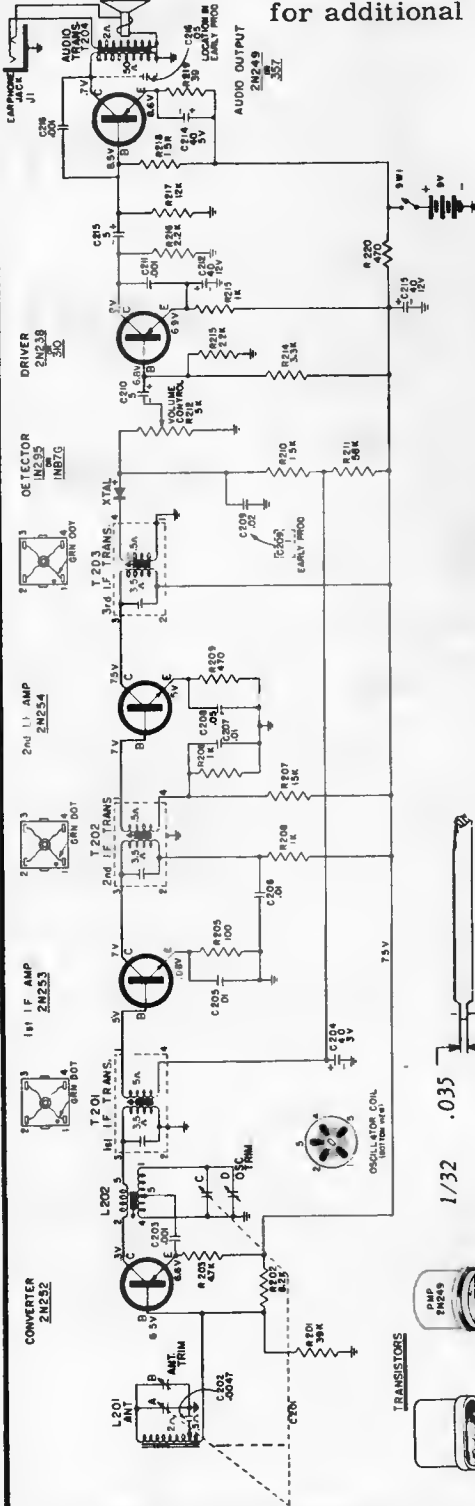

NOTE:  
1. DURING SERVICING TOTAL BATTERY CURRENT SHOULD BE MEASURED. WITH NO SIGNAL AND VOLUME CONTROL ADJUSTED TO MINIMUM, BATTERY CURRENT SHOULD BE 10 MA. FROM POINTS INDICATED TO GND. WITH TUNING MEASUREMENTS MADE WITH A VTVM FROM POINTS INDICATED TO GND. WITH TUNING CAPACITOR AT MAXIMUM, VOLUME CONTROL AT MINIMUM, BATTERY SOURCE AT 9 VOLTS

Alignment Tool

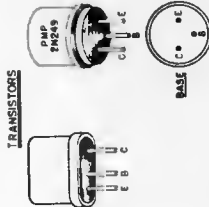
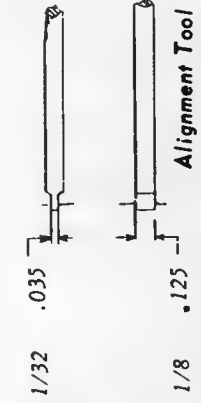

(Additional service material is on the next page at right)

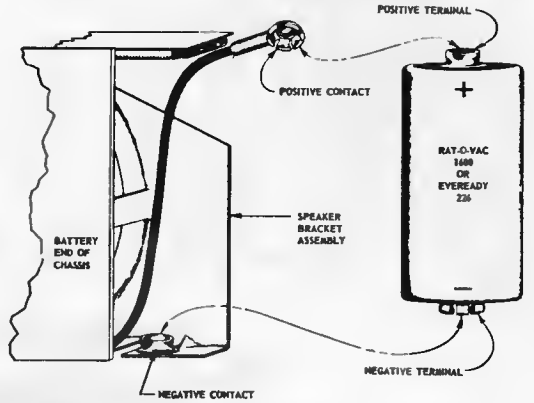

Battery Installation

### IF ALIGNMENT REQUIREMENTS

1. Form a 4 or 5 turn loop of wire and connect across the signal generator output cable.
2. Signal generator capable of covering frequencies of 455 KC and the entire broadcast band with provisions for modulation.
3. VTVM or output meter.
4. Keep the output of the signal generator low enough just to give an indication on the VTVM or output meter. If the peak is broad or double peak occurs when rocking the IF slug adjustment, the signal generator output is excessive. Either further decoupling of the generator loop or decreasing the generator output is necessary.
5. Set the volume control and tuning capacitor to maximum.

Loosely couple signal modulated from the generator to:	Generator Frequency	Connect VTVM or output meter across the voice coil and adjust.
Loop L 201	455 KC	T203, T202 and T201 in order indicated for max. output  Reduce generator output if necessary for T202 and T201 adjustments.*

\*It is recommended that a fiber aligning tool that snugly fits the slot in the ferrite core be used to prevent chipping of the slot.

### RF ALIGNMENT REQUIREMENTS

1. Steps 1, 2 and 3 also apply as in the IF alignment.
2. Keep the output of the signal generator low enough just to give an indication on the VTVM or output meter.
3. Set the volume control to maximum.

Loosely couple modulated signal, from generator to:	Generator Frequency	C201 Setting	Connect VTVM or output meter across voice coil and adjust for max. output
Loop L 201	1625 KC	Min.	Oscillator Trim. "D"
" "	1400 KC	1400 KC	Antenna Trim. "B"

Caution: Be sure during RF Alignment that the hand or any objects on the bench do not come in close contact with the antenna loop or detuning will occur and alignment will be incorrect.



VOLUME R-17, MOST-OFTEN-NEEDED 1957 RADIO SERVICING INFORMATION  
 WESTINGHOUSE Chassis V-2278-2, Models H-610P5, H-611P5, H-612P5, Continued

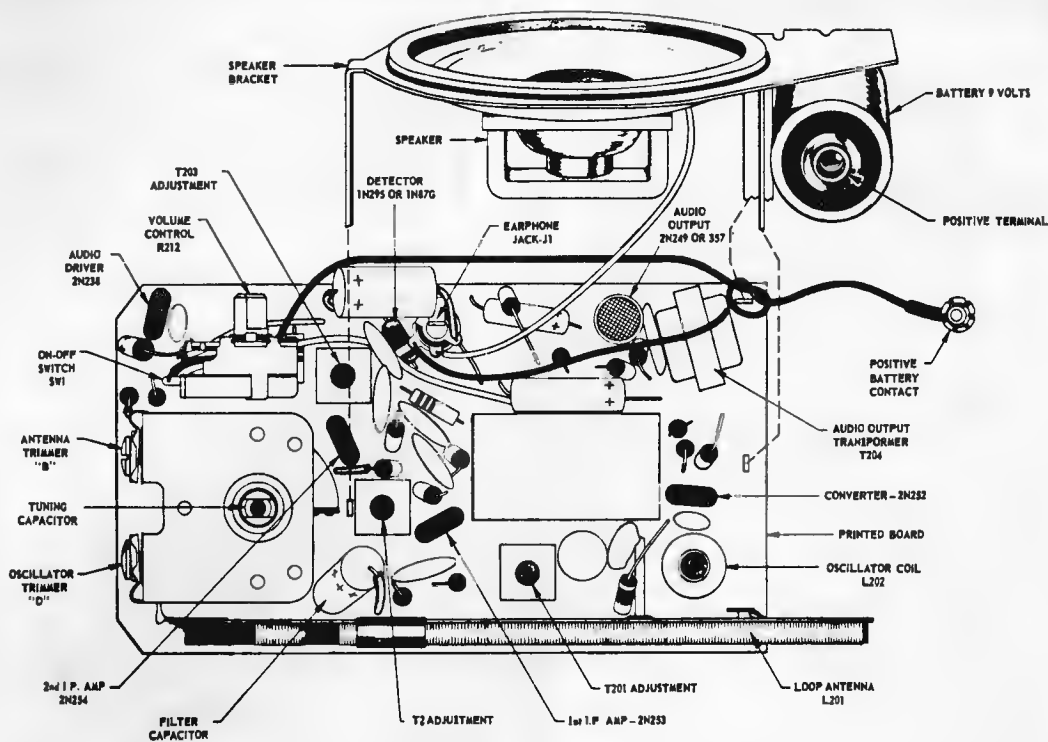

Top View Ports Layout

BOARD REMOVAL

1. Remove the screw located in center of the tuning knob. Turn the dial to the high frequency end and grip the tuning knob with one hand. Remove the screw by turning it in a counter clockwise direction. Do not cause any undue strain on the tuning capacitor.
2. Remove back of cabinet by loosening coin-slot screw on back. Remove the 1/4" self tapping screw located at tuning condenser end of board.
3. Hold radio in the palm of the hand with the open back side up. Grip the board with the other hand and slide it down towards the tuning capacitor end of the cabinet, until the upper end of the speaker bracket is free of the plastic lip. Now raise this end of the board over lip and slide it out of the cabinet.
4. To insert the board into the cabinet use the reverse procedure, being careful to lock the speaker bracket under both recesses provided in the cabinet front.

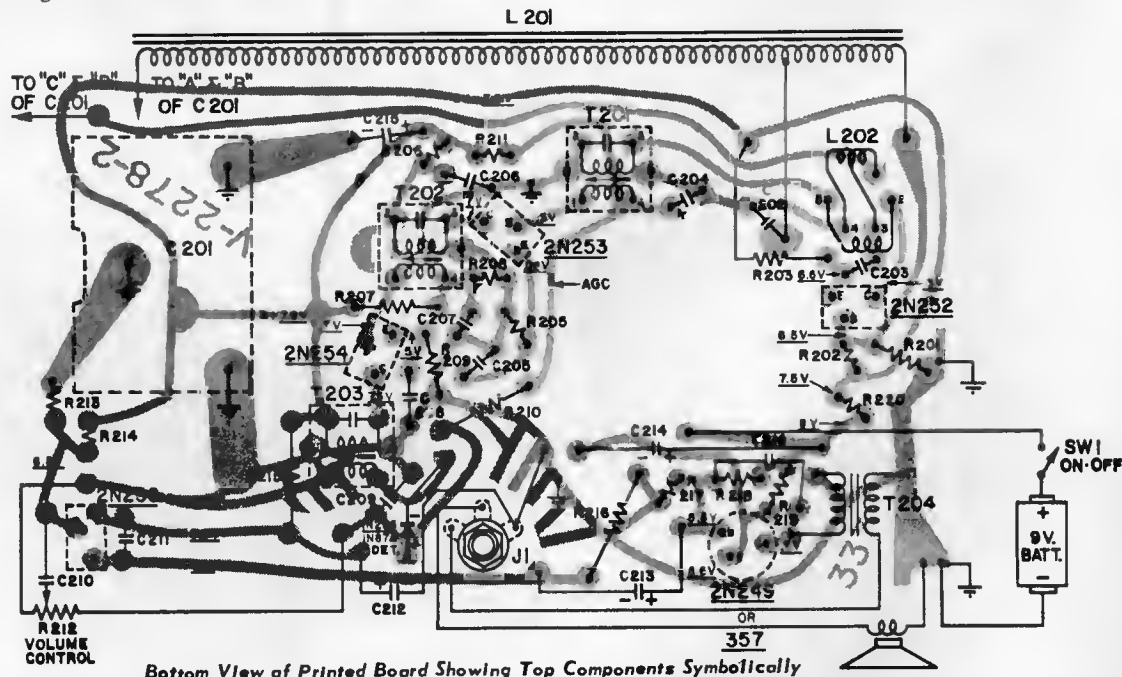

Bottom View of Printed Board Showing Top Components Symbolically

# Westinghouse

## CHASSIS V-2295-1

## MODEL 602P7

### CHASSIS REMOVAL FOR SERVICING

1. Remove the front control knobs.
2. Open the back cover.
3. Unclip the battery cable assembly from the two nine volt batteries and remove the batteries.
4. Remove the two 1/4" self tapping screws which secure the printed board to the cabinet.
5. The printed board can now be removed from the cabinet. Use care and watch to see that the oscillator coil and antenna loop do not touch the printed board mounting bracket located on either side of cabinet. The tuning capacitor, C1, should be in a fully closed position.

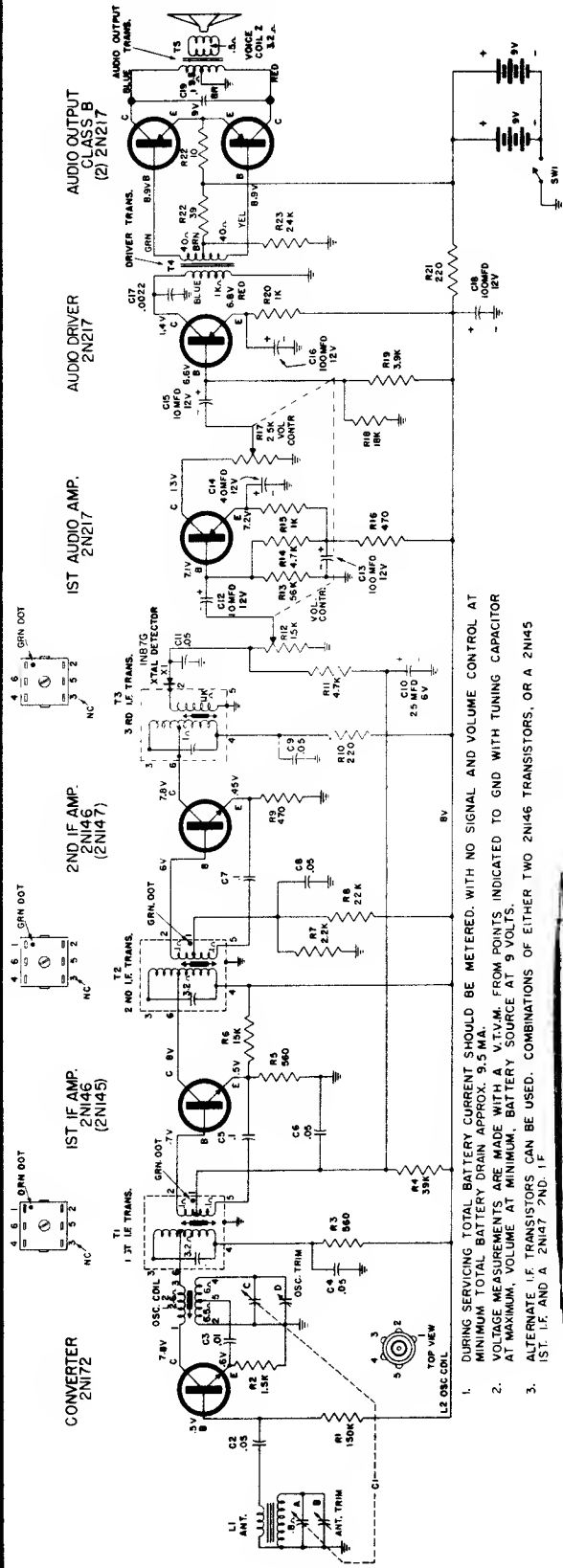

1. DURING SERVICING TOTAL BATTERY CURRENT SHOULD BE METERED. WITH NO SIGNAL AND VOLUME CONTROL AT MINIMUM TOTAL BATTERY DRAIN APPROX. 9.5 MA.  
 2. VOLTAGE MEASUREMENTS ARE MADE WITH A V.T.V.M. FROM POINTS INDICATED TO GND WITH TUNING CAPACITOR AT MAXIMUM. VOLUME AT MINIMUM. BATTERY SOURCE AT 9 VOLTS.  
 3. ALTERNATE I.F. TRANSISTORS CAN BE USED. COMBINATIONS OF EITHER TWO 2N146 TRANSISTORS, OR A 2N145 1ST. I.F. AND A 2N147 2ND. I.F.

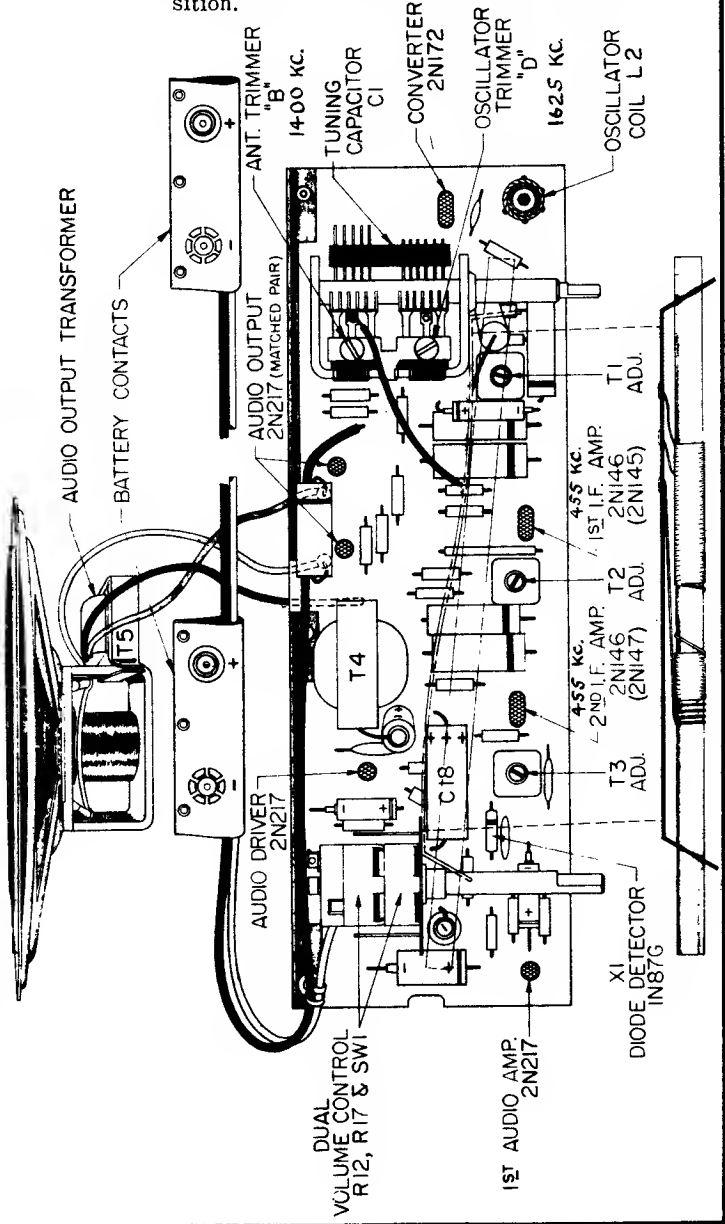

# Westinghouse

Models H-617P7, -A, H-618P7, -A,  
H-619P7, -A, Chassis V-2278-3

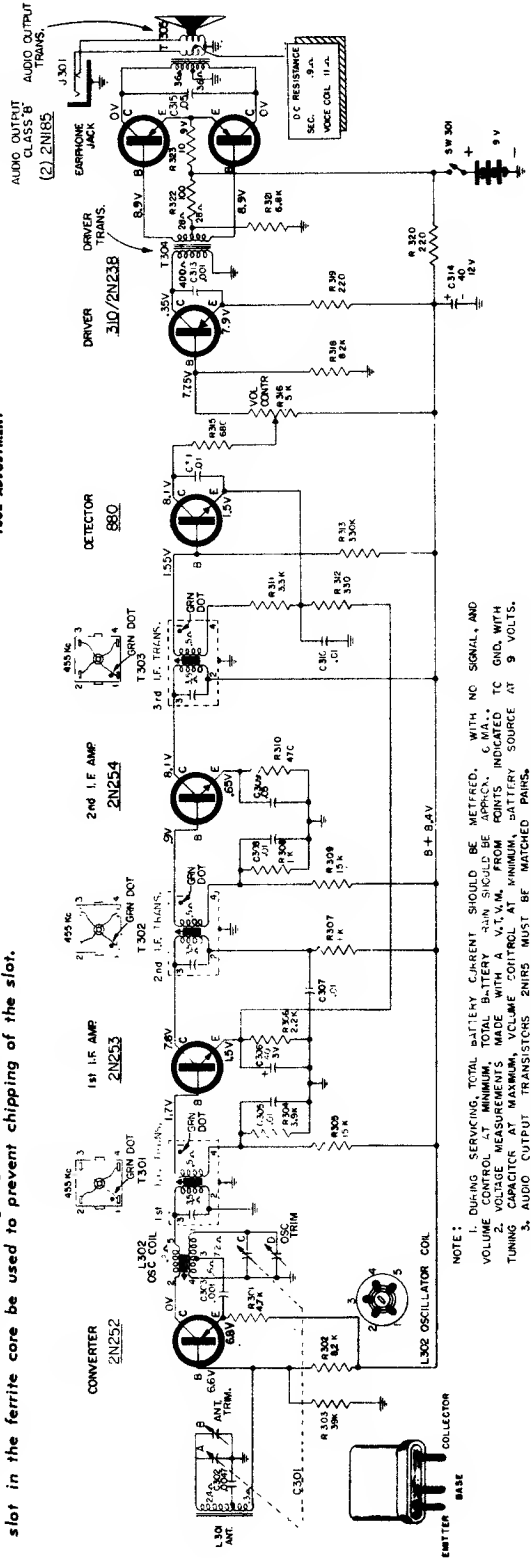
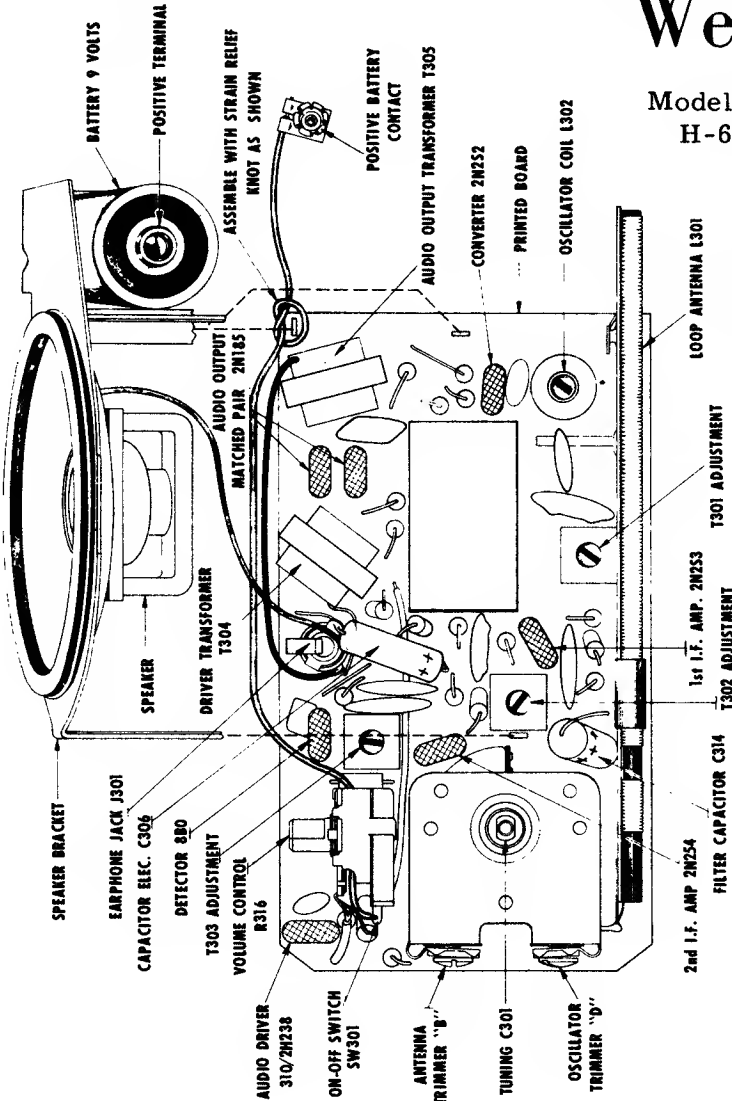

- IF ALIGNMENT REQUIREMENTS**
- Form a 4 or 5 turn loop of wire and connect across the signal generator output cable.
  - Signal generator capable of covering frequencies of 455 KC and the entire broadcast band with provisions for modulation.
  - VTVM or output meter.
  - Keep the output of the signal generator low enough just to give an indication on the VTVM or output meter. If the peak is broad or double peak occurs when rocking the IF slug adjustment, the signal generator output is excessive. Either further decoupling of the generator loop or decreasing the generator output is necessary.
  - Set the volume control and tuning capacitor to maximum.

Loosely couple signal modulated from the generator to:	Generator Frequency	Connect VTVM or output meter across the voice coil and adjust:
Loop L301	455 KC	T303, T302 and T301 in order indicated for max. output (Reduce generator output if necessary for T302 and T301 adjustments. *)

**RF ALIGNMENT REQUIREMENTS**

Loosely couple modulated signal, from generator to:	C301	Connect VTVM or output meter across voice coil and adjust for max. output
Loop L301	1625 KC	Min. Oscillator Trim "D"
" "	1400 KC.	Antenna Trim "B"

\*It is recommended that a fiber aligning tool that snugly fits the slot in the ferrite core be used to prevent chipping of the slot.

NOTE: 1. DURING SERVICING, TOTAL BATTERY CURRENT SHOULD BE METFERED, WITH NO SIGNAL, AND VOLUME CONTROL AT MINIMUM. TOTAL BATTERY CURRENT SHOULD BE INDICATED TO GND. WITH NO SIGNAL, AND VOLUME CONTROL AT MAXIMUM. 2. TUNING CAPACITOR AT MAXIMUM. 3. AUDIO OUTPUT TRANSISTORS 2N185 MUST BE MATCHED PAIRS. 4. ALL CAPACITORS ARE IN MICROFARADS AND RESISTORS ARE IN OHMS.

# ZENITH RADIO CORPORATION

## MODELS Z400, Z402 & Z404

### CHASSIS 4Z40 & 4Z41

NOTES  
 ALL VOLTAGES MEASURED FROM COMMON RETURN TO POINTS INDICATED WITH AN A.C.-D.C. OR VACUUM TUBE VOLTMETER  
 ALL VOLTAGES ARE D.C. UNLESS OTHERWISE SPECIFIED  
 ALL CONDENSERS ARE MICROFARADS UNLESS OTHERWISE SPECIFIED  
 ALL CONDENSERS ARE +20% TOLERANCE UNLESS OTHERWISE SPECIFIED  
 ALL RESISTORS ARE +20% TOLERANCE, 1/2 WATT, CARBON UNLESS OTHERWISE SPECIFIED.  
 USE ONLY ZENITH NON-INDUCTIVE ELECTROLYTIC CONDENSERS FOR REPLACEMENT

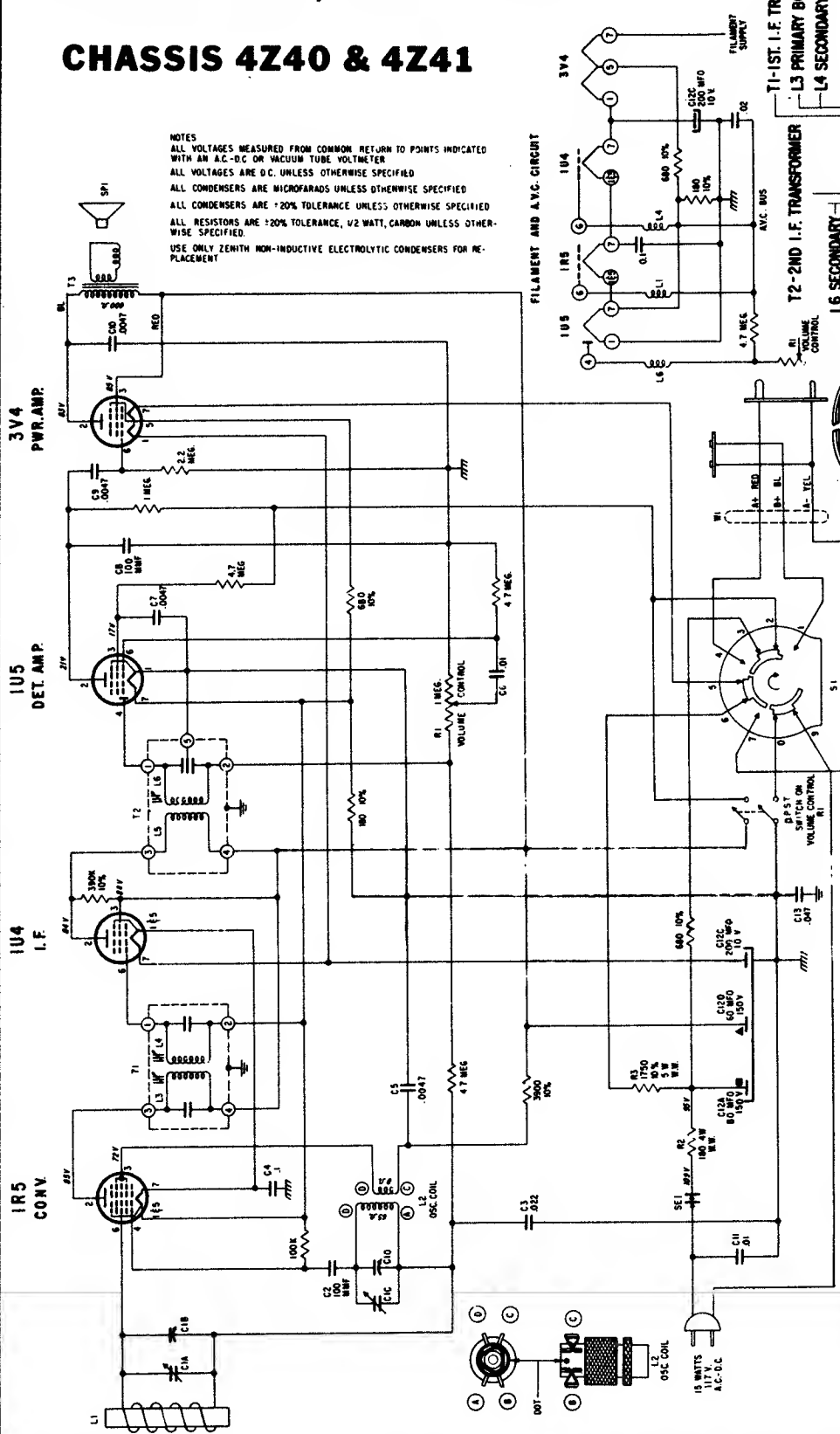
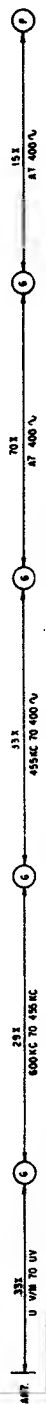

### Alignment Procedure

OPERATION	CONNECT OSC. TO	DUMMY ANTENNA	INPUT SIG. FREQUENCY	SET DIAL AT	TRIMMERS	PURPOSE
1	Converter Grid	.5 Mfd.	455 Kc.	600 Kc.	L-3, 4, 6	For I.F. Alignment
2	Single Turn Loosely Coupled to Wave Magnet	.....	1600 Kc.	1600 Kc.	C1C	Set Osc. to Dial Scale
3	.....	.....	1400 Kc.	1400 Kc.	C1A	Antenna Alignment

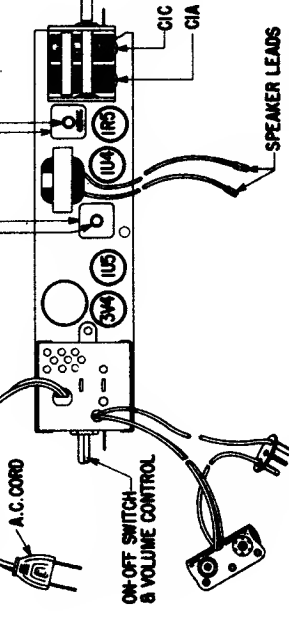
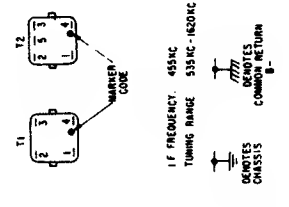

# ZENITH RADIO MODEL Y506L, CHASSIS 5Y40

## Alignment Procedure

OPERATION	CONNECT OSC. TO	DUMMY ANTENNA	INPUT SIG. FREQUENCY	SET DIAL AT	TRIMMERS	PURPOSE
1	Converter Grid	.5 Mfd.	455 Kc.	600 Kc.	L4, 5, 6, 7	For I.F. Alignment
2	Single Turn Loosely Coupled to Wave-Magnet	.....	1600 Kc.	1600 Kc.	C1C	Set Osc. to Dial Scale
3	.....	.....	1400 Kc.	1400 Kc.	C1A	Antenna Alignment

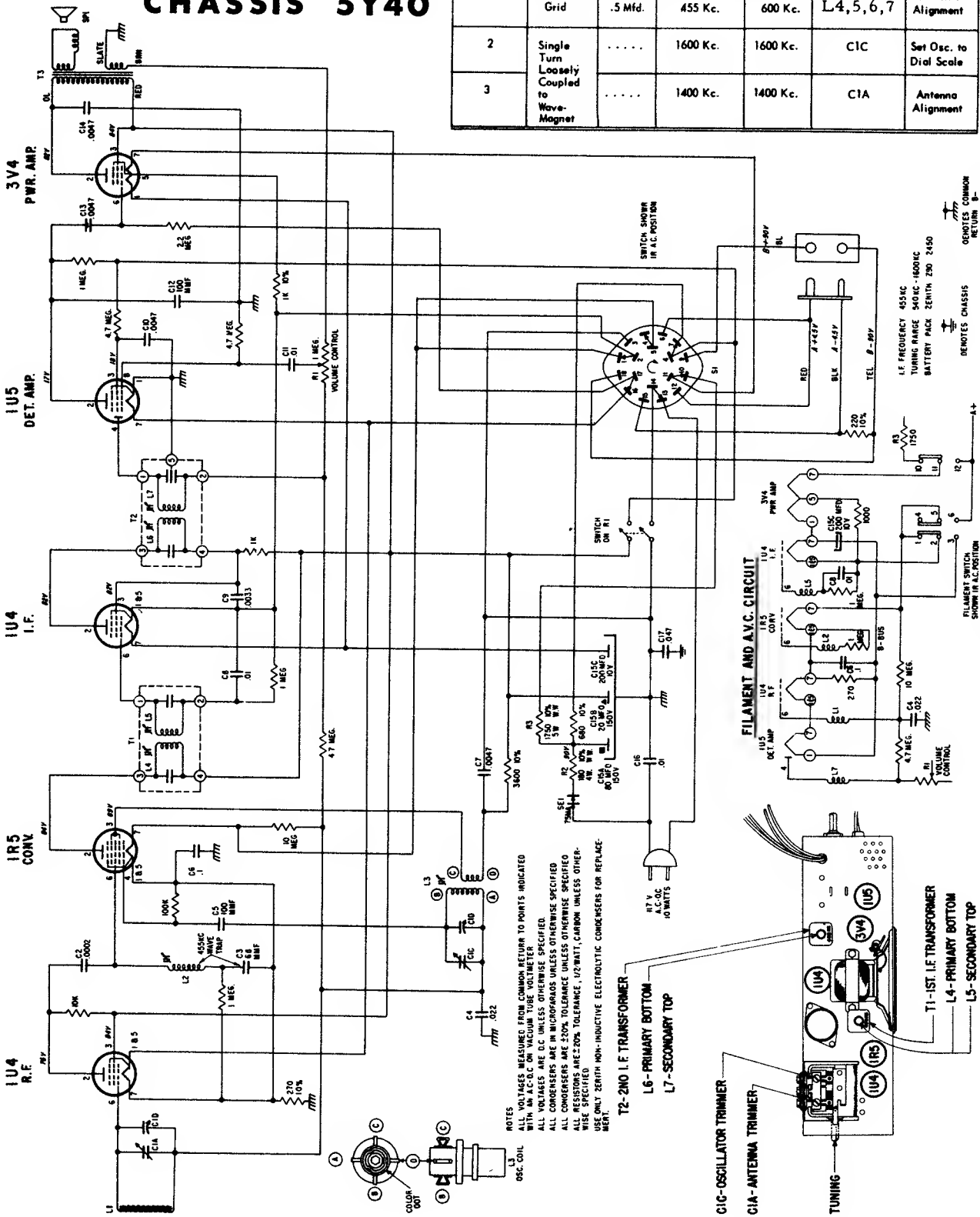

NOTES  
ALL VOLTAGES MEASURED FROM COMMON RETURN TO POINTS INDICATED WITH AN A.C./D.C. ON VACUUM TUBE VOLTMETER.  
ALL VOLTAGES ARE D.C. UNLESS OTHERWISE SPECIFIED.  
ALL CONDENSERS ARE IN MICROFARADS UNLESS OTHERWISE SPECIFIED.  
ALL RESISTORS ARE IN OHMS UNLESS OTHERWISE SPECIFIED.  
ALL RESISTORS ARE 200% TOLERANCE, 1/2" WATT, CARBON UNLESS OTHERWISE SPECIFIED.  
WERNER TUNING NON-INDUCTIVE ELECTROLYTIC CONDENSERS FOR REPLACEMENT.

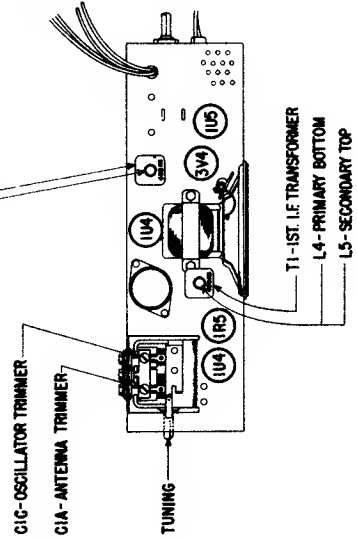
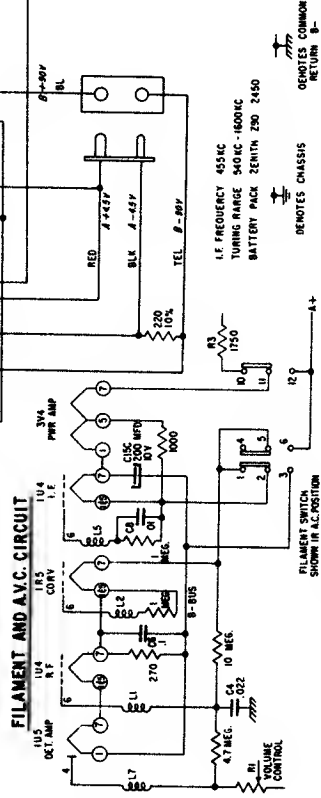

# ZENITH RADIO CORPORATION

## MODEL Z512Y, G & F, CHASSIS 5Z02

## MODEL Z511R, CHASSIS 5Z01

The 5Z01 and 5Z02 are identical superheterodyne chassis except chassis 5Z02 has a phono jack, utilizes heavier speaker magnets and has different cabinet styling.

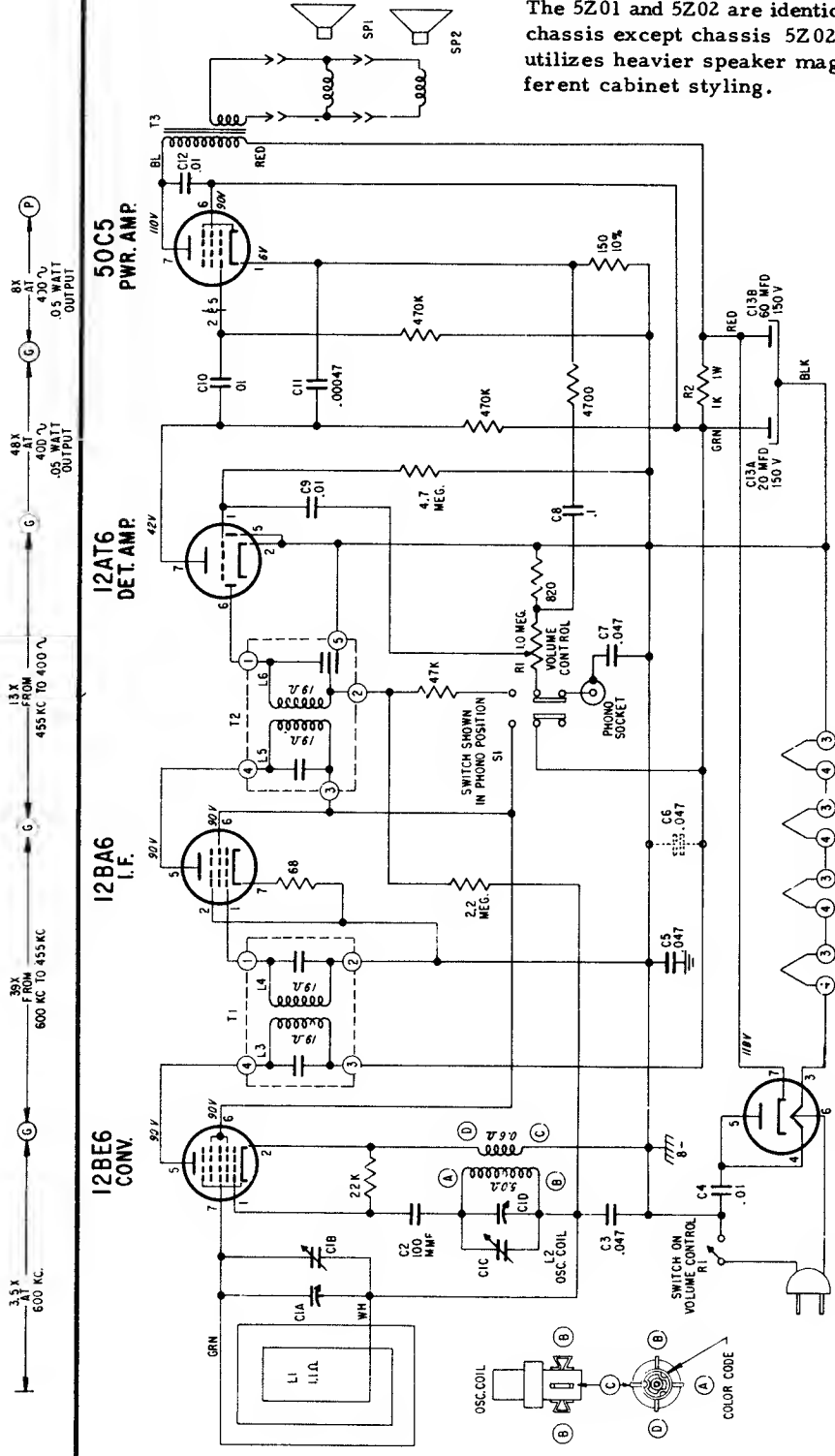
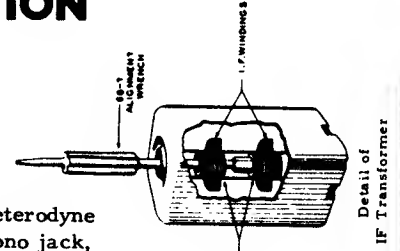

**NOTES:**  
USE ONLY ZENITH NON-INDUCTIVE ELECTROLYTIC CONDENSERS FOR REPLACEMENT. IF ANY OTHER TYPE OF ELECTROLYTIC IS USED, IT WILL BE NECESSARY TO ADD PARTS SHOWN IN DOTTED LINES.  
I.F. TRANSFORMER MARKER AT LUG NO. 4 AND NUMBERED CLOCKWISE AS VIEWED FROM BOTTOM OF CHASSIS.  
ALL VOLTAGES MEASURED FROM COMMON RETURN TO POINTS INDICATED WITH AN A.C. D.C. OR VACUUM TUBE VOLTMETER.  
ALL VOLTAGES ARE D.C. UNLESS OTHERWISE SPECIFIED.  
ALL RESISTOR TOLERANCES ± 20%, CARBON, 1/2 WATT UNLESS OTHERWISE SPECIFIED.

### CHASSIS 5Z02

I.F. FREQUENCY 455 KC  
TUNING RANGE 535-1620 KC

⊖ DENOTES CHASSIS RETURN B—  
⊕ DENOTES COMMON RETURN B—

### ALIGNMENT PROCEDURE

OPERATION	CONNECT OSCILLATOR TO ANTENNA	DUMMY ANTENNA	INPUT SIG. FREQUENCY	SET DIAL AT	TRIMMERS	PURPOSE
1	Converter Grid	.5 Mfd.	455 Kc.	600 Kc.	L3, L4, L5, L6	Align I.F. for maximum output
2	One Turn Loop Coupled Loosely to Wave Magnet	---	1600 Kc.	1600 Kc.	C1C	Set Oscillator to Dial Scale.
3		---	1400 Kc.	1400 Kc.	C1B	Align Antenna Stage

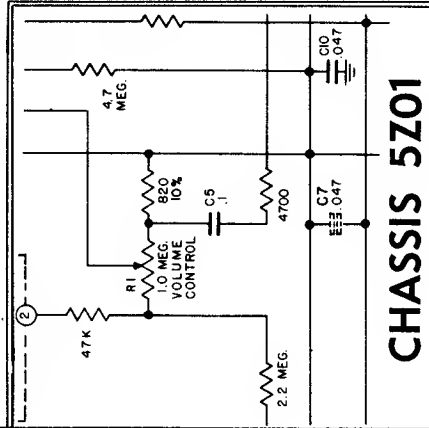

ZENITH RADIO CORPORATION MODELS Z522, G, V & R CHASSIS 5Z03

NOTES

ALL VOLTAGES MEASURED FROM COMMON RETURN TO POINTS INDICATED WITH AN A, C, D, C OR VACUUM TUBE VOLTMETER  
 ALL VOLTAGES ARE D.C. UNLESS OTHERWISE SPECIFIED  
 ALL RESISTORS ARE 20% TOLERANCE, 1/2 WATT, CARBON UNLESS OTHERWISE SPECIFIED  
 USE ONLY ZENITH NON-INDUCTIVE ELECTROLYTIC CONDENSERS FOR REPLACEMENT  
 IF ANY OTHER TYPE OF ELECTROLYTIC IS USED IT WILL BE NECESSARY TO ADD CB SHOWN IN DOTTED LINES  
 I.F. TRANSFORMER NUMBERING STARTS WITH #1 TERMINAL, AS FIRST TERMINAL CLOCKWISE AND ADJACENT TO MARKER AS VIEWED FROM BOTTOM OF CHASSIS

I.F. FREQUENCY 455 KC.  
 TUNING RANGE  
 535-1820 KC.

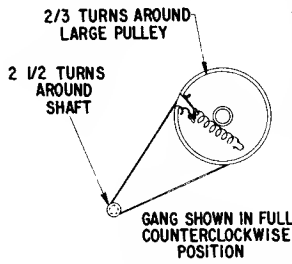

DIAL CORD DRIVE

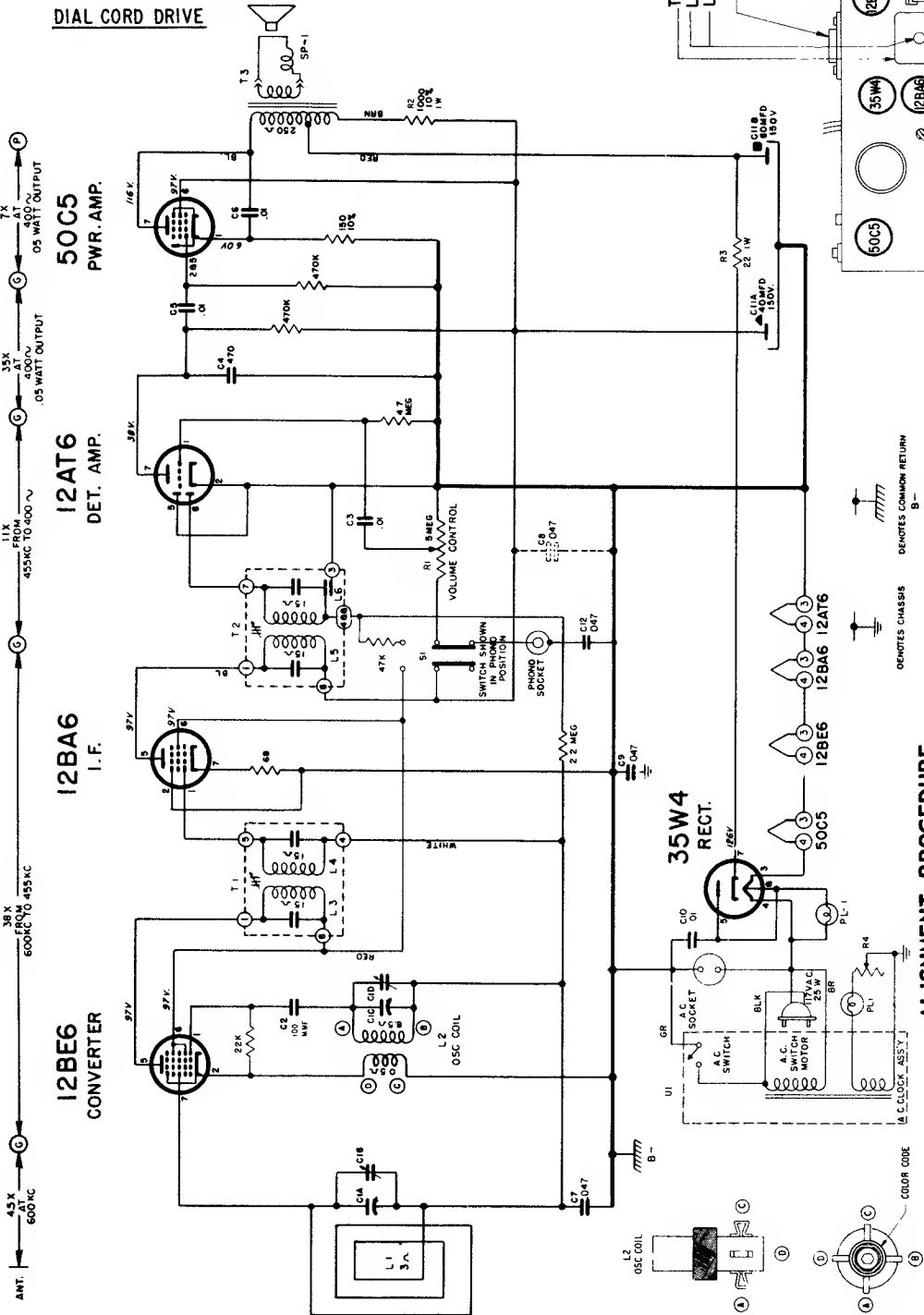

ALIGNMENT PROCEDURE

Operation	Connect Oscillator To	Dummy Antenna	Input Sig. Frequency	Set Dial At	Trimmers	Purpose
1	Converter Grid	.5 Mfd.	455 Kc.	600 Kc.	L3, L4, L5, L6	For I.F. Alignment.
2	One Turn Loop Coupled Loosely to Wave Magnet	—	1600 Kc.	1600 Kc.	C1D	Set Oscillator to Dial Scale
3	—	—	1400 Kc.	1400 Kc.	C1B	Align Antenna Stage

# Zenith Radio Corporation

## Models Z524W & Y Chassis 5Z04

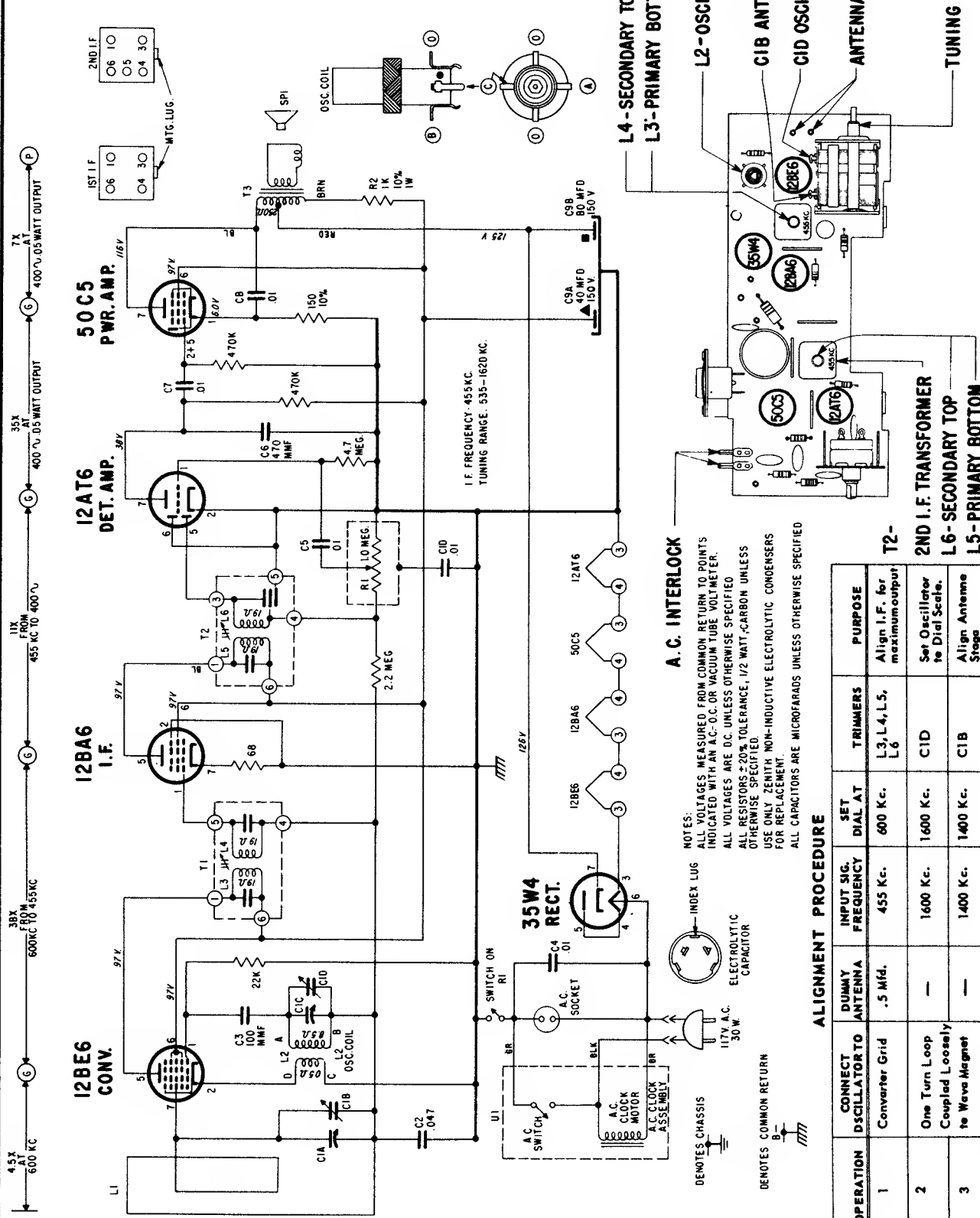

**NOTES:**  
 ALL VOLTAGES MEASURED FROM COMMON RETURN TO POINTS INDICATED WITH AN A.C. OR VACUUM TUBE VOLT METER.  
 ALL VOLTAGES ARE D.C. UNLESS OTHERWISE SPECIFIED  
 ALL VOLTAGES ARE D.C. UNLESS OTHERWISE SPECIFIED  
 ALL RESISTORS ±20% TOLERANCE, 1/2 WATT, CARBON UNLESS OTHERWISE SPECIFIED.  
 USE ONLY ZENITH NON-INDUCTIVE ELECTROLYTIC CONDENSERS FOR REPLACEMENT.  
 ALL CAPACITORS ARE MICROFARADS UNLESS OTHERWISE SPECIFIED

**ALIGNMENT PROCEDURE**

OPERATION	CONNECT DUMMY OSCILLATOR TO Converter Grid	DUMMY ANTENNA .5 Mfd.	INPUT SIG. FREQUENCY 455 Kc.	SET DIAL AT 600 Kc.	TRIMMERS L3, L4, L5, L6	PURPOSE Align i.f. for maximum output
1	—	—	1600 Kc.	1600 Kc.	C1D	Set Oscillator to Dial Scale.
2	One Turn Loop Coupled Loosely to Wave Magnet	—	1400 Kc.	1400 Kc.	C1B	Align Antenna Stags
3	—	—	—	—	—	—



# Zenith Radio Corporation

## Models Z508B, L & V Chassis 5Z05

The I.F. transformers incorporated in this receiver are of the new permeability tuned type. The advantage of an I.F. transformer of this type is its extreme stability under various humidity and temperature conditions. The upper coil is the secondary and the lower the primary. When adjusting these I.F. transformers the tuning wrench 68-19 can be inserted into the top slug, rotated until maximum output is obtained and then dropped down to the lower slug and the same operation repeated. The tuning wrench is so designed that turning one slug does not affect the adjustment of the other.

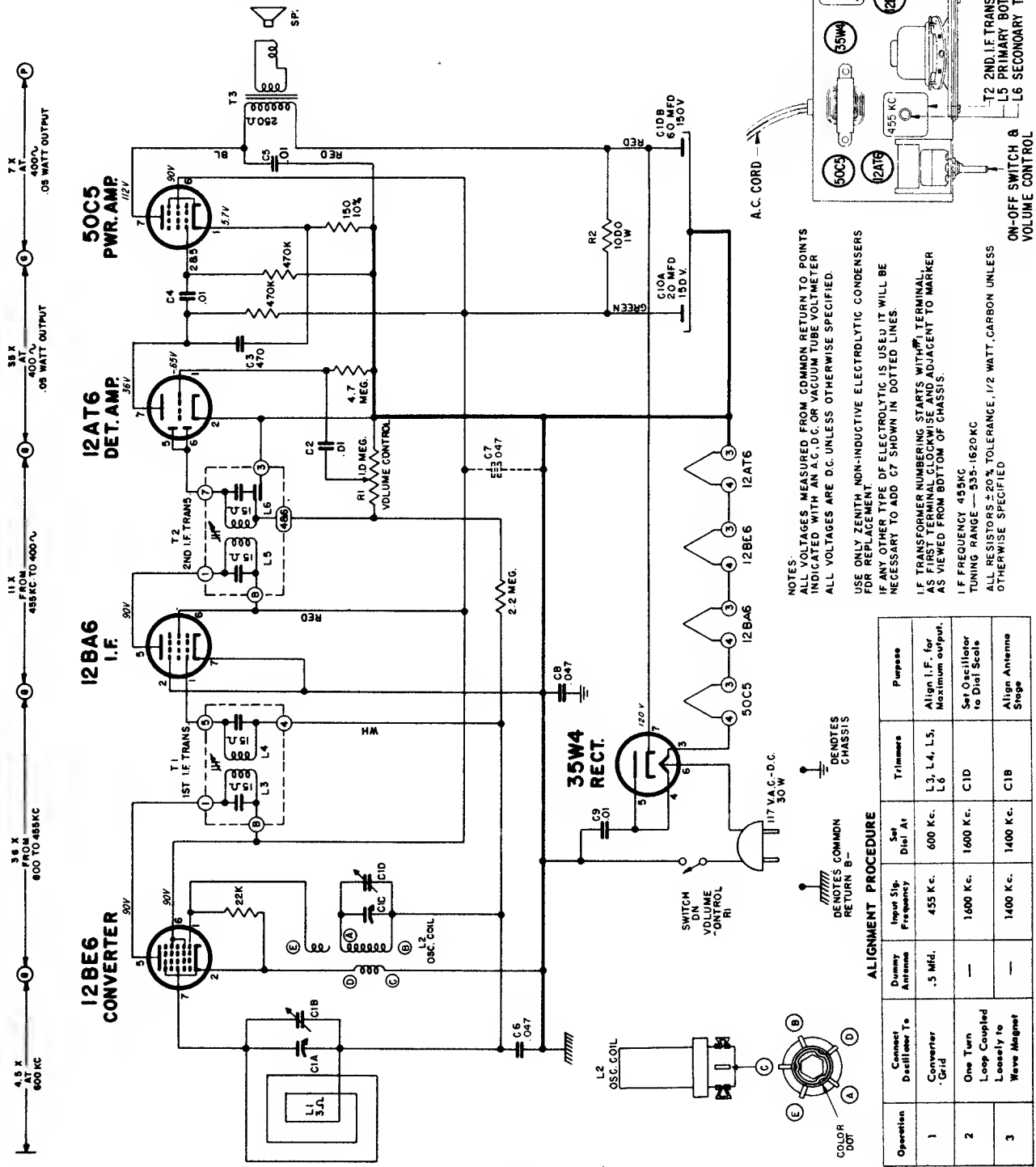

NOTES:  
 ALL VOLTAGES MEASURED FROM COMMON RETURN TO POINTS INDICATED WITH AN A.C., D.C. OR VACUUM TUBE VOLTMETER  
 ALL VOLTAGES ARE D.C. UNLESS OTHERWISE SPECIFIED.  
 USE ONLY ZENITH NON-INDUCTIVE ELECTROLYTIC CONDENSERS FOR REPLACEMENT.  
 IF ANY OTHER TYPE OF ELECTROLYTIC IS USED IT WILL BE NECESSARY TO ADD C7 SHOWN IN DOTTED LINES.  
 I.F. TRANSFORMER NUMBERING STARTS WITH THE TERMINAL AS VIEWED FROM BOTTOM OF CHASSIS.  
 I.F. FREQUENCY 455KC  
 TUNING RANGE — 535-1620KC  
 ALL RESISTORS ± 20% TOLERANCE, 1/2 WATT, CARBON UNLESS OTHERWISE SPECIFIED

**ALIGNMENT PROCEDURE**

Operation	Connect Oscillator To	Dummy Antenna	Input Slip	Set Dial At	Trimmers	Purpose
1	Converter Grid	.5 Mfd.	455 Kc.	600 Kc.	L3, L4, L5, L6	Align I.F. for Maximum output.
2	One Turn Loop Coupled Loosely to Wave Magnet	—	1600 Kc.	1600 Kc.	CID	Set Oscillator to Dial Scale
3	—	—	1400 Kc.	1400 Kc.	CIB	Align Antenna Stage

ZENITH RADIO CORPORATION MODELS Z515, W & Y Chassis 5Z06

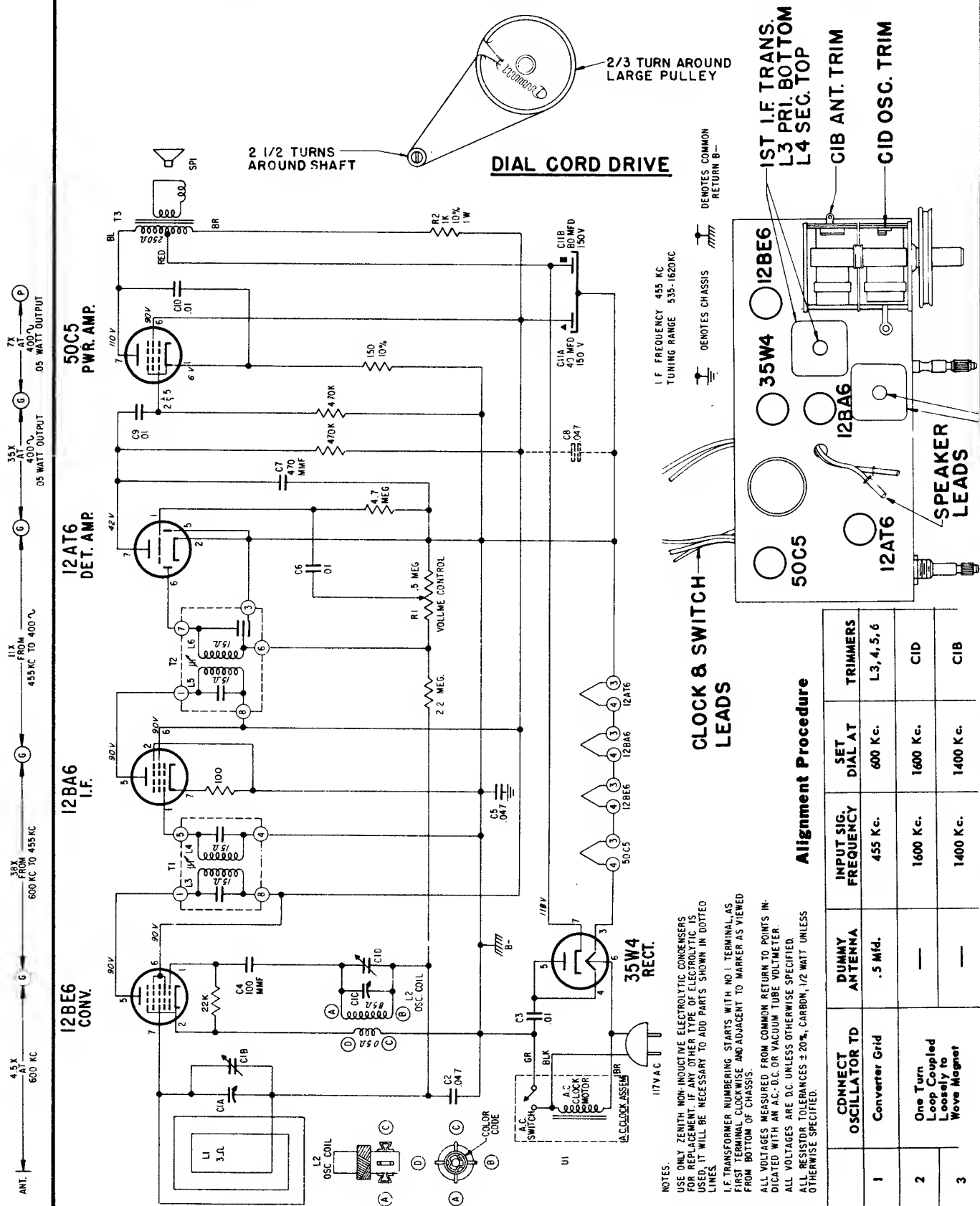

I.F. FREQUENCY 455 KC  
TUNING RANGE 535-1620KC

DEMOTES CHASSIS  
DEMOTES COMMON  
RETURN B-

CLOCK & SWITCH LEADS

Alignment Procedure

CDCONNECT OSCILLATOR TD	DUMMY ANTENNA	INPUT SIG. FREQUENCY	SET DIAL AT	TRIMMERS
1	Converter Grid	455 Kc.	600 Kc.	L3, 4, 5, 6
2	One Turn Loop Coupled loosely to Wave Magnet	1600 Kc.	1600 Kc.	CID
3		1400 Kc.	1400 Kc.	CIB

NOTES:  
USE ONLY ZENITH NON-INDUCTIVE ELECTROLYTIC CONDENSERS FOR REPLACEMENT. IF ANY OTHER TYPE OF ELECTROLYTIC IS USED, IT WILL BE NECESSARY TO ADD PARTS SHOWN IN DOTTED LINES.  
I.F. TRANSFORMER NUMBERING STARTS WITH NO. 1 TERMINAL AS FIRST TERMINAL CLOCKWISE AND ADJACENT TO MARKER AS VIEWED FROM BOTTOM OF CHASSIS.  
ALL VOLTAGES MEASURED FROM COMMON RETURN TO POINTS INDICATED WITH AN A.C.-D.C. OR VACUUM TUBE VOLTMETER.  
ALL VOLTAGES ARE D.C. UNLESS OTHERWISE SPECIFIED.  
ALL RESISTOR TOLERANCES ± 20%. CARBON, 1/2 WATT UNLESS OTHERWISE SPECIFIED.

# ZENITH RADIO CORPORATION

## Chassis 5Z07 Model Z519R, W, Y, P, V

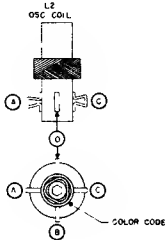
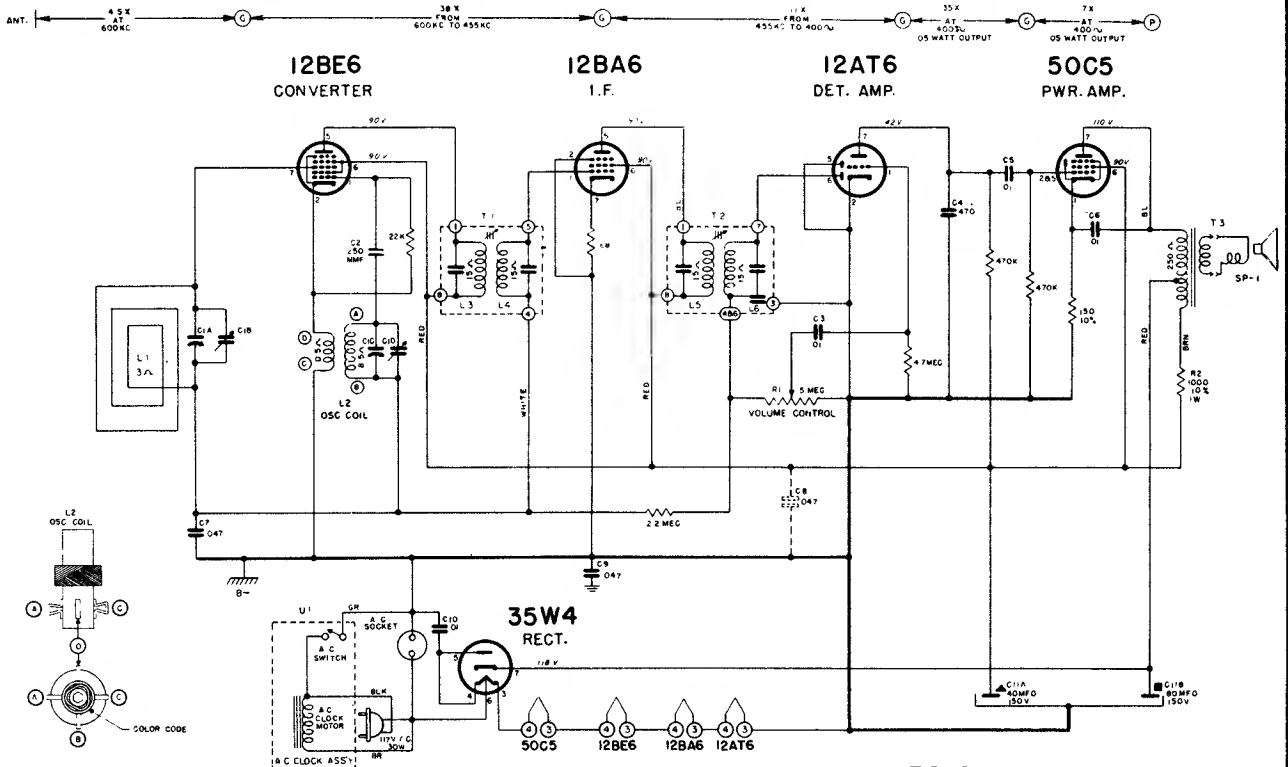

**NOTES:**  
 ALL VOLTAGES MEASURED FROM COMMON RETURN TO POINTS INDICATED WITH AN A.C. D.C. OR VACUUM TUBE VOLTMETER  
 ALL VOLTAGES ARE D.C. UNLESS OTHERWISE SPECIFIED  
 ALL RESISTORS ARE 20% TOLERANCE, 1/2 WATT UNLESS OTHERWISE SPECIFIED  
 USE ONLY ZENITH NON-INDUCTIVE ELECTROLYTIC CONDENSERS FOR REPLACEMENT  
 IF ANY OTHER TYPE OF ELECTROLYTIC IS USED IT WILL BE NECESSARY TO ADD CR SHOWN IN DOTTED LINES  
 I.F. TRANSFORMER NUMBERING STARTS WITH "1" TERMINAL, AS FIRST TERMINAL CLOCKWISE AND ADJACENT TO MARKER AS VIEWED FROM BOTTOM OF CHASSIS

I.F. FREQUENCY 455KC  
 TUNING RANGE  
 535-1620 KC

If a unit, such as the oscillator coil of IF transformer is to be removed, heat the mounting lugs with a pencil type soldering iron and move them away from the soldered connection with a long nose pliers or metal pick. Continue heating the lugs and brush away the molten solder with a small stiff glue brush. Remove the defective unit by lifting it off the chassis. Before inserting the new unit, be certain that the lug holes are open and free from solder. Forcing a lug against a solder filled lug hole may break the bond between the chassis base and the "printed" wiring. It is, therefore, necessary to exercise care when replacing units.

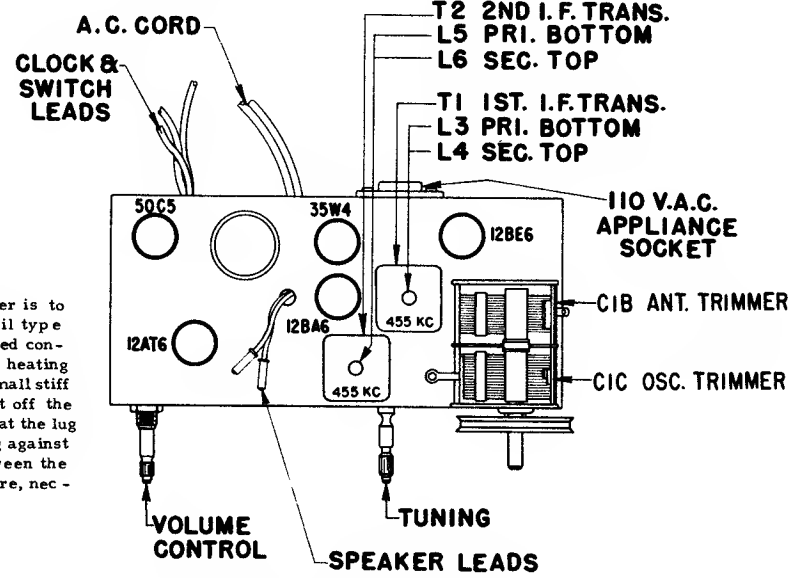
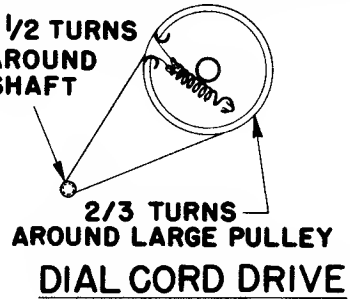

### ALIGNMENT PROCEDURE

OPERATION	CONNECT OSCILLATOR TO	DUMMY ANTENNA	INPUT SIG. FREQUENCY	SET DIAL AT	TRIMMERS	PURPOSE
1	Converter Grid	.5 Mfd.	455 Kc.	600 Kc.	L3, L4, L5, L6	Align I.F. for maximum output
2	One Turn Loop Coupled Loosely to Wave Magnet	—	1600 Kc.	1600 Kc.	C1C	Set Oscillator to Dial Scale.
3		—	1400 Kc.	1400 Kc.	C1B	Align Antenna Stage

# Zenith Radio Corporation

## Model Z550G Chassis 5Z08

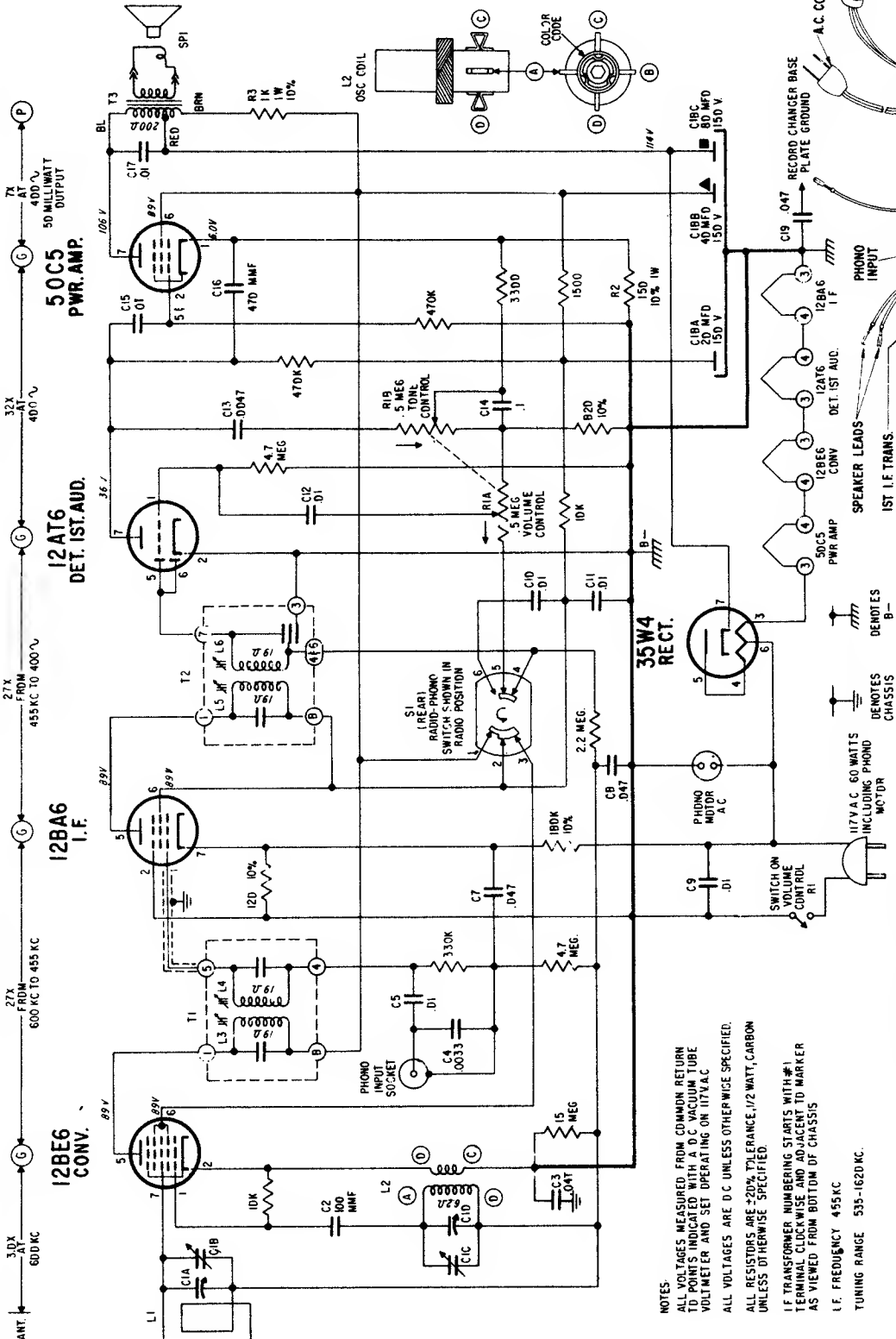

### ALIGNMENT PROCEDURE

OPERATION	CONNECT OSCILLATOR TO ANTENNA	DUMMY FREQUENCY	INPUT SIG. FREQUENCY	SET DIAL AT	TRIMMERS	PURPOSE
1	Converter Grid	.5 Mfd.	455 Kc.	600 Kc.	L3, L4, L5, L6	Align I.F. for maximum output
2	One Turn Loop Coupled Loosely to Wave Magnet	—	1600 Kc.	1600 Kc.	C1C	Set Oscillator to Dial Scale.
3	—	—	1400 Kc.	1400 Kc.	C1B	Align Antenna Stage

NOTES:  
 ALL VOLTAGES MEASURED FROM COMMON RETURN TO POINTS INDICATED WITH A D.C. VACUUM TUBE VOLTMETER AND SET OPERATING ON 117V A.C.  
 ALL RESISTORS ARE D.C. UNLESS OTHERWISE SPECIFIED.  
 ALL VOLTAGES ARE D.C. UNLESS OTHERWISE SPECIFIED.  
 ALL RESISTORS ARE ±20% TOLERANCE, 1/2 WATT, CARBON UNLESS OTHERWISE SPECIFIED.  
 I.F. TRANSFORMER NUMBERING STARTS WITH #1 TERMINAL CLOCKWISE AND ADJACENT TO MARKER AS VIEWED FROM BOTTOM OF CHASSIS  
 I.F. FREQUENCY 455 KC.  
 TUNING RANGE 535-1620 KC.

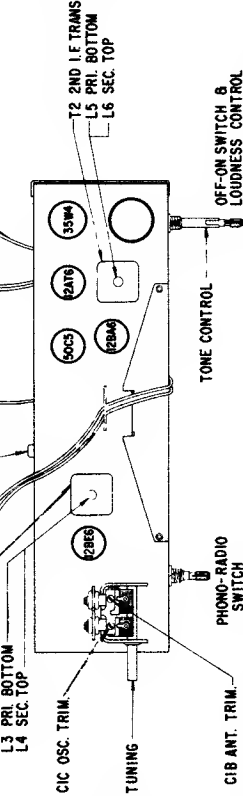

## ZENITH RADIO CORPORATION

### MODEL Z510G, R & W, CHASSIS 5Z10

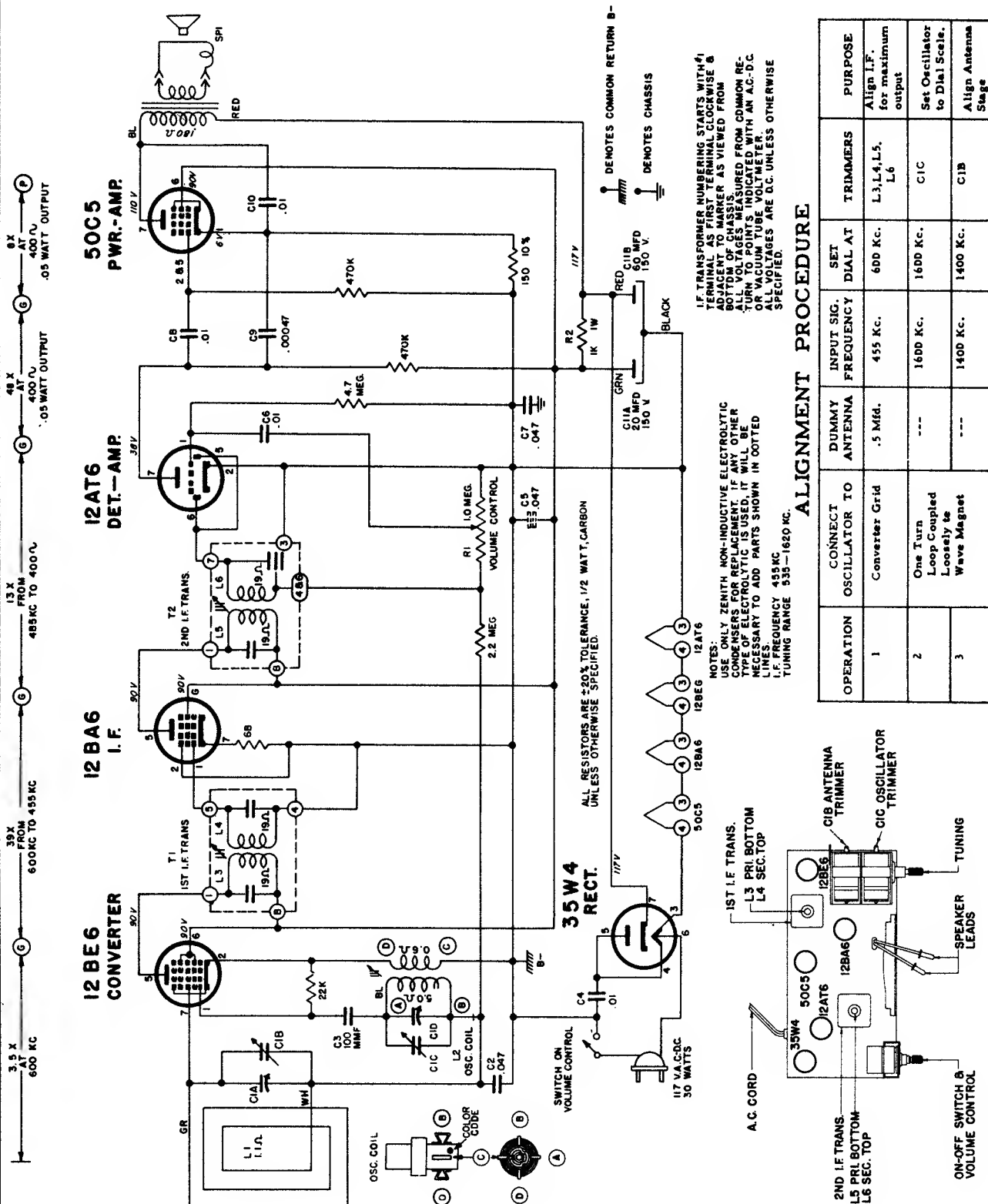

# ZENITH RADIO CORPORATION MODELS HFZ18R & HFZ19E, CHASSIS 5Z21

Zenith Radio Chassis 5Z21,  
Models HFZ18R and HFZ19E

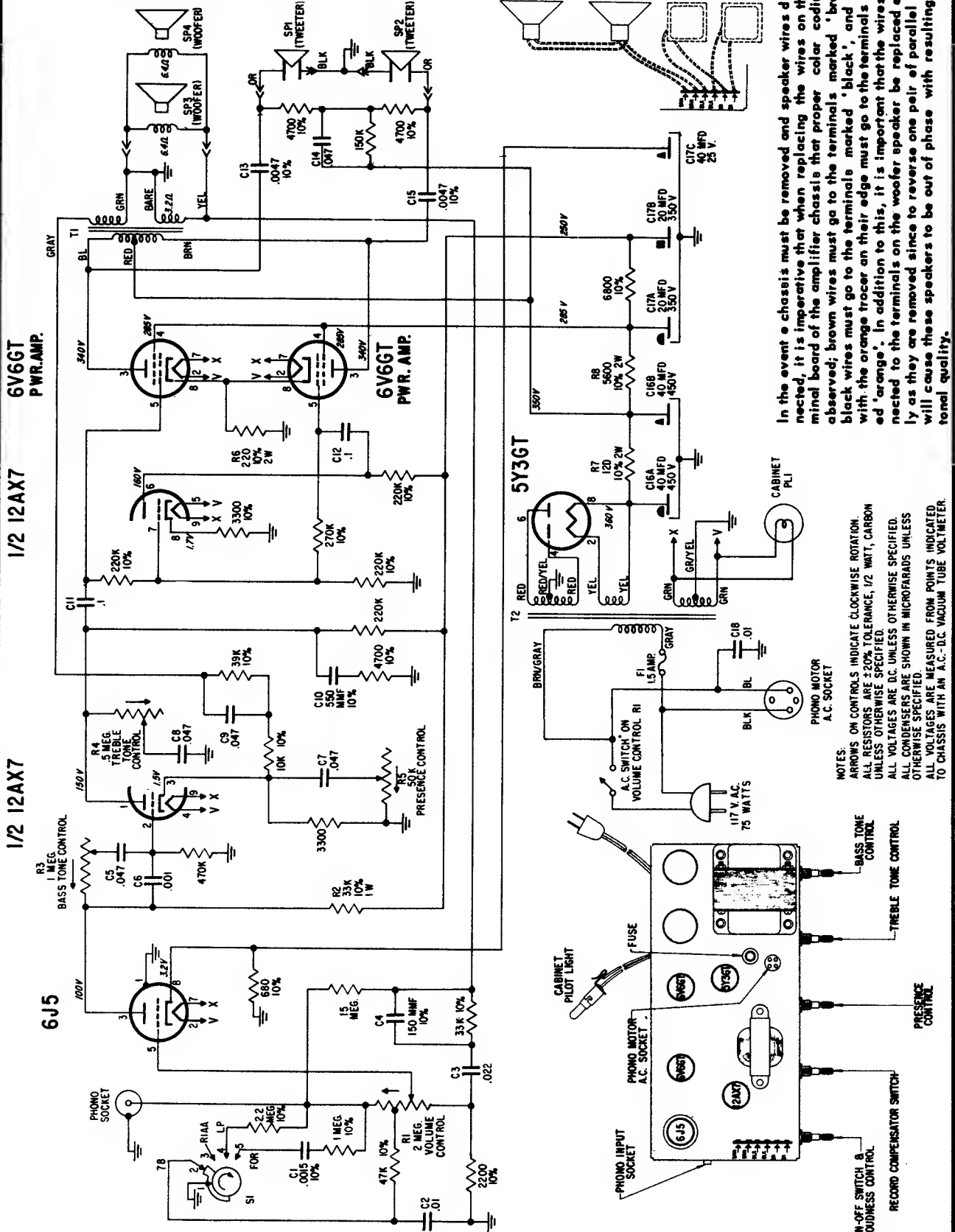

In the event a chassis must be removed and speaker wires disconnected, it is imperative that when replacing the wires on the terminal board of the amplifier chassis that proper color coding be observed; brown wires must go to the terminals marked 'brown', black wires must go to the terminals marked 'black', and wires with the orange tracer on their edge must go to the terminals marked 'orange'. In addition to this, it is important that the wires connected to the terminals on the woofer speaker be replaced exactly as they are removed since to reverse one pair of parallel leads will cause these speakers to be out of phase with resulting poor tonal quality.

NOTES:  
ARROWS ON CONTROLS INDICATE CLOCKWISE ROTATION UNLESS OTHERWISE SPECIFIED.  
ALL RESISTORS ARE ±20% TOLERANCE, 1/2 WATT, CARBON UNLESS OTHERWISE SPECIFIED.  
ALL VOLTAGES ARE DC UNLESS OTHERWISE SPECIFIED.  
ALL CAPACITORS ARE SHOWN IN MICROFARADS UNLESS OTHERWISE SPECIFIED.  
ALL VOLTAGES ARE MEASURED FROM POINTS INDICATED TO CHASSIS WITH AN A.C.-D.C. VACUUM TUBE VOLTMETER.

**ZENITH RADIO CORPORATION**  
**MODELS Z624, G, W & Y**  
**CHASSIS 6Z03**

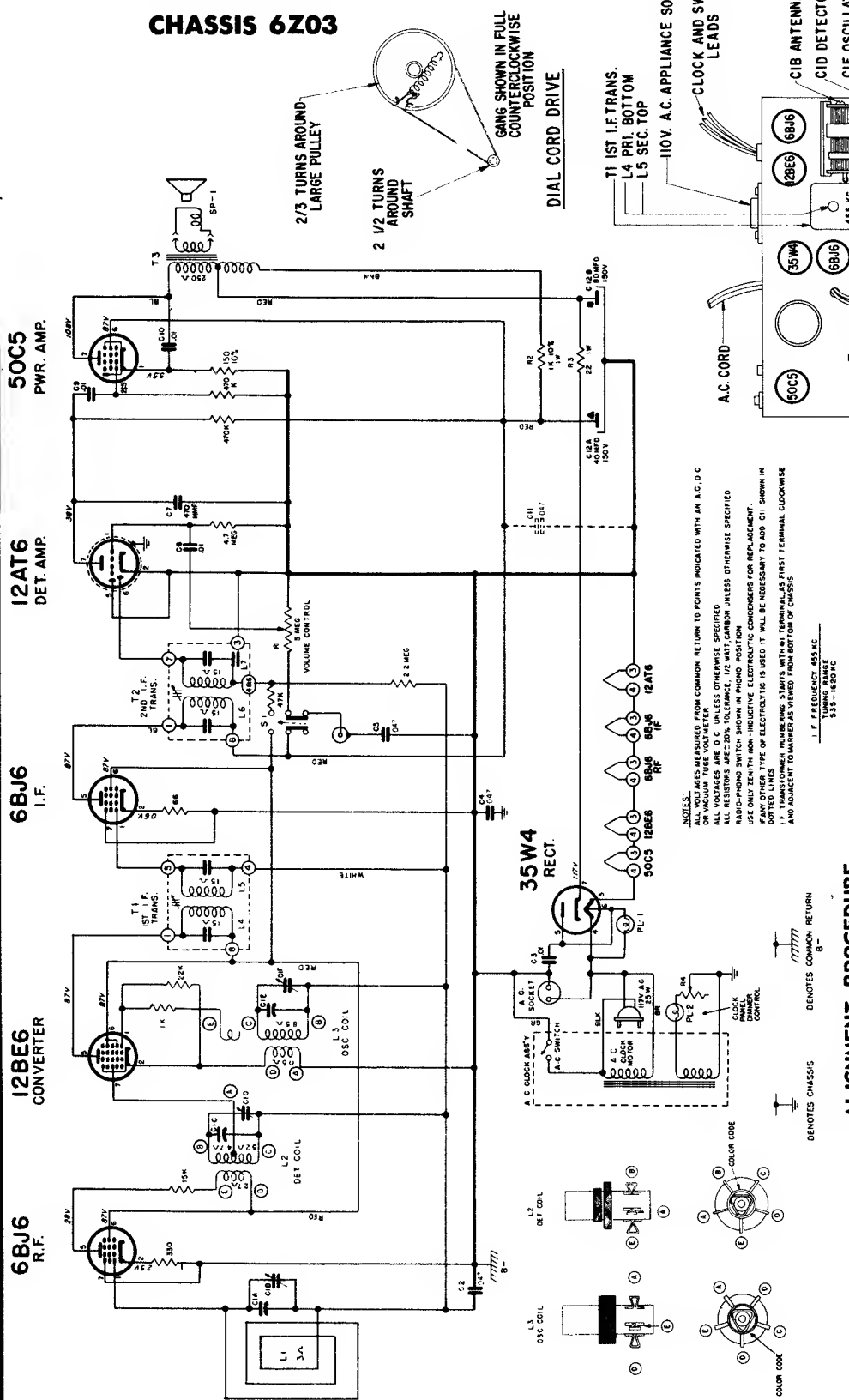

NOTES:  
 ALL VOLTAGES MEASURED FROM COMMON RETURN TO POINTS INDICATED WITH AN A.C. OR VACUUM TUBE VOLTMETER UNLESS OTHERWISE SPECIFIED.  
 ALL RESISTORS ARE 20% TOLERANCE, 1/2 WATT CARBON UNLESS OTHERWISE SPECIFIED.  
 RADIO-PHONO SWITCH SHOWN IN PHONO POSITION.  
 USE ONLY ZENITH NON-INDUCTIVE ELECTROLYTIC CONDENSERS FOR REPLACEMENT.  
 IF ANY OTHER TYPE OF ELECTROLYTIC IS USED IT WILL BE NECESSARY TO ADD C11 SHOWN IN I.F. TRANSFORMER NUMBERS STARTS WITH 4M TERMINALS FIRST TERMINAL CLOCKWISE AND ADJACENT TO MARKER AS VIEWED FROM BOTTOM OF CHASSIS.

12BE6 FREQUENCY 455 KC  
 535-1420 KC

**ALIGNMENT PROCEDURE**

Operation	Connect Oscillator To	Dummy Antenna	Input Sig. Frequency	Set Dial At	Trimmers	Purpose
1	Converter Grid	.5 Mfd.	455 Kc.	600 Kc.	L4, L5, L6, L7	For I.F. Alignment.
2	One Turn Loop Coupled Loosely to Wave Magnet	—	1600 Kc.	1600 Kc.	C1F	Set Oscillator to Dial Scale
3		—	1400 Kc.	1400 Kc.	C1D, C1B	Align Detector and Antenna Stage

# ZENITH RADIO MODELS Z615 W,F,G,R CHASSIS 6Z05

(Alignment data on the next page.)

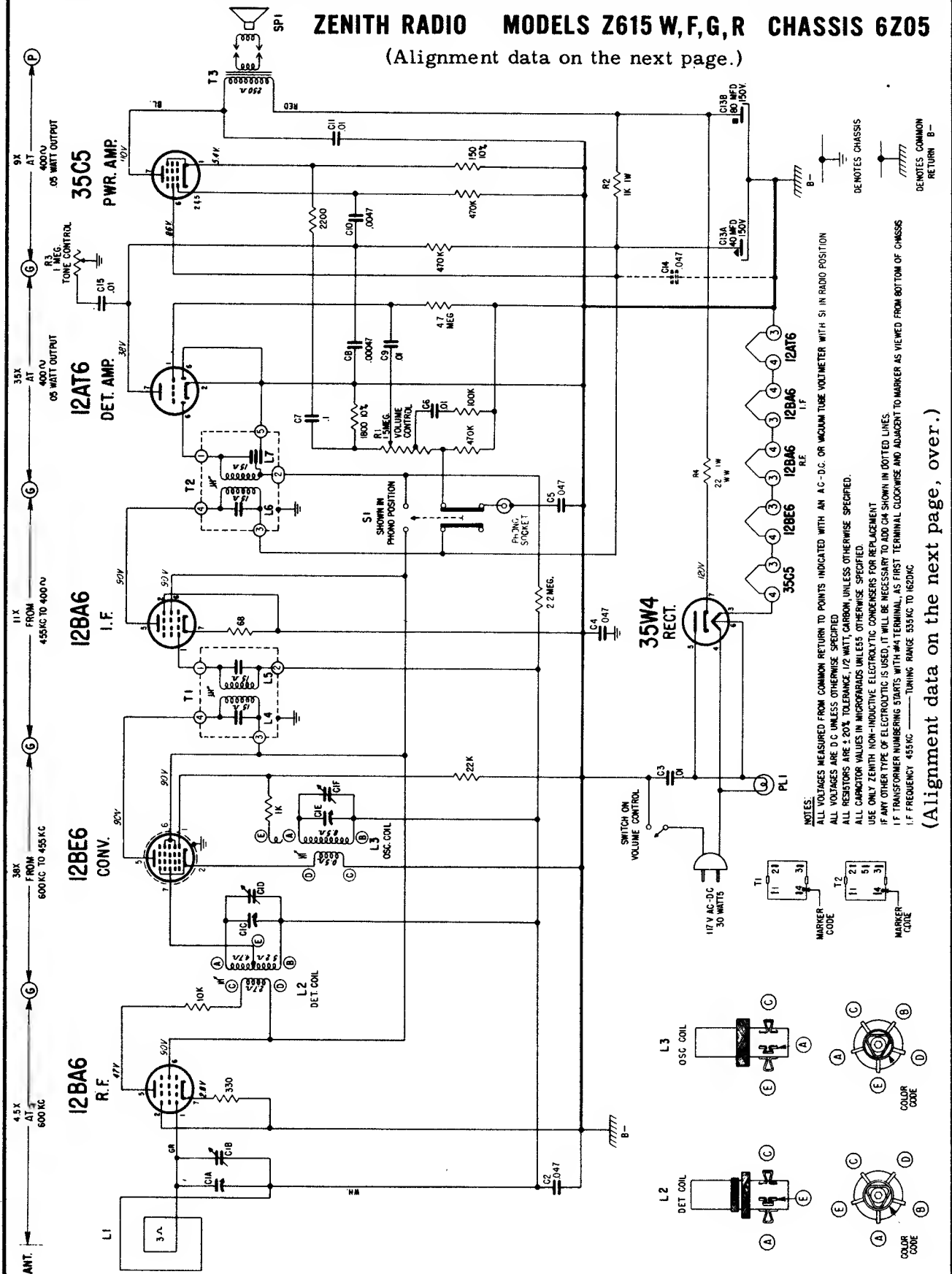

NOTES:  
 ALL VOLTAGES MEASURED FROM COMMON RETURN TO POINTS INDICATED WITH AN A.C.-D.C. OR WACUUM TUBE VOLTMETER WITH S1 IN RADIO POSITION  
 ALL VOLTAGES ARE D.C. UNLESS OTHERWISE SPECIFIED  
 ALL RESISTORS ARE 4.20% TOLERANCE 1/2 WATT CARBON UNLESS OTHERWISE SPECIFIED.  
 ALL CAPACITOR VALUES IN MICROGRAMS UNLESS OTHERWISE SPECIFIED.  
 USE ONLY ZENITH NON-INDUCTIVE ELECTROLYTIC CONDENSERS FOR REPLACEMENT  
 IF ANY OTHER TYPE OF ELECTROLYTIC IS USED, IT WILL BE NECESSARY TO ADD OHM SHOWN IN DOTTED LINES.  
 I.F. TRANSFORMER NUMBERING STARTS WITH #41 TERMINAL, AS FIRST TERMINAL CLOCKWISE AND ADJACENT TO MARKER AS VIEWED FROM BOTTOM OF CHASSIS  
 I.F. FREQUENCY 455KC — TUNING RANGE 535KC TO 1620KC

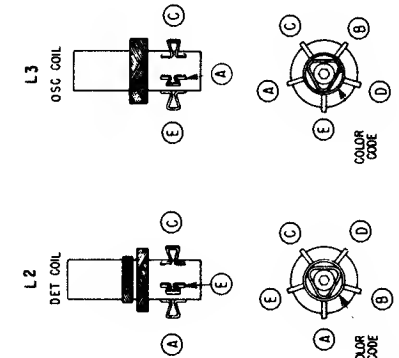

(Alignment data on the next page, over.)



ZENITH RADIO CORPORATION MODELS Z615 W,F,G,R CHASSIS 6Z05

(Alignment Information, Continued)

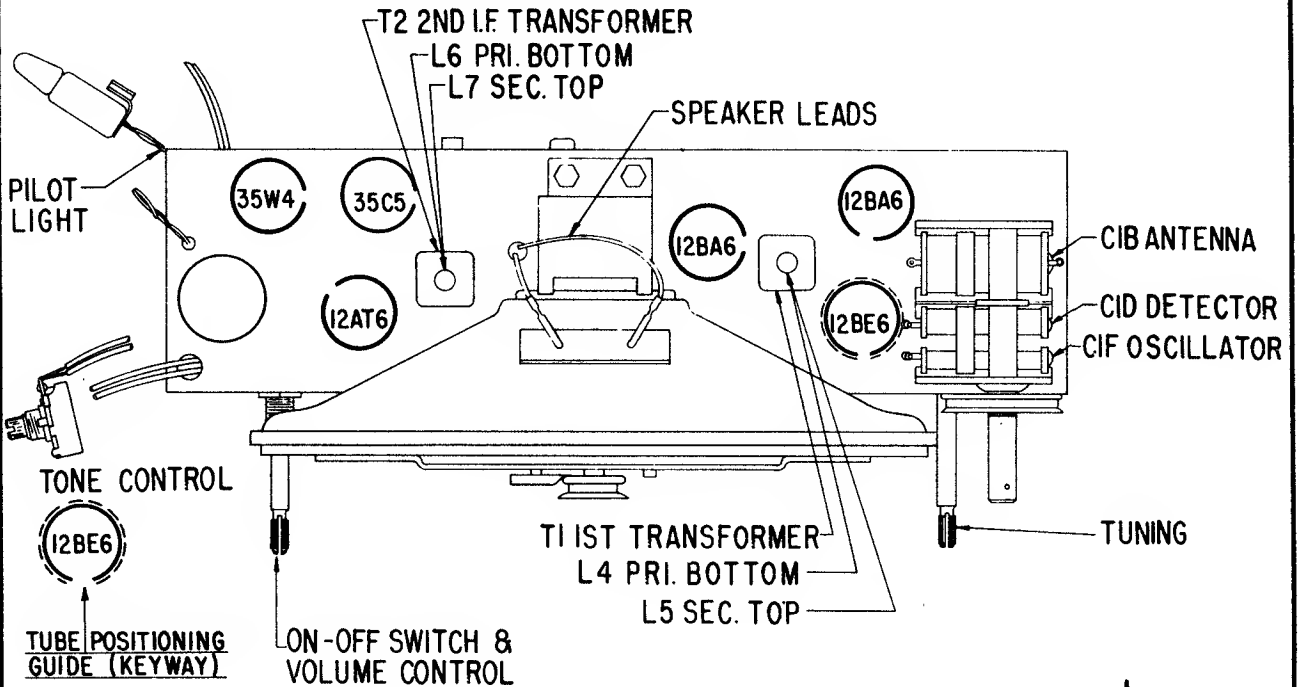

ALIGNMENT PROCEDURE

OPERATION	CONNECT OSCILLATOR TO	DUMMY ANTENNA	INPUT SIG. FREQUENCY	SET DIAL AT	TRIMMERS	PURPDE
1	Converter Grid	.5 Mfd.	455 Kc.	600 Kc.	L4, L5, L6, L7	For I.F. Alignment
2	One Turn Loop Coupled Loosely to Wave Magnet	—	1600 Kc.	1600 Kc.	C1F	Set Oscillator to Dial Scale
3		—	1400 Kc.	1400 Kc.	C1D	Detector Alignment
4		—	1400 Kc.	1400 Kc.	C1B	Align Antenna Stage

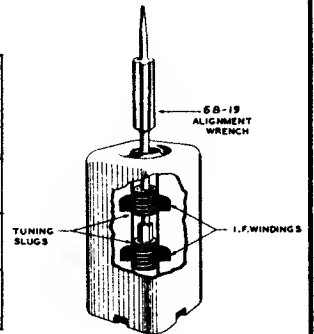

ZENITH RADIO CORPORATION MODEL ZP7L

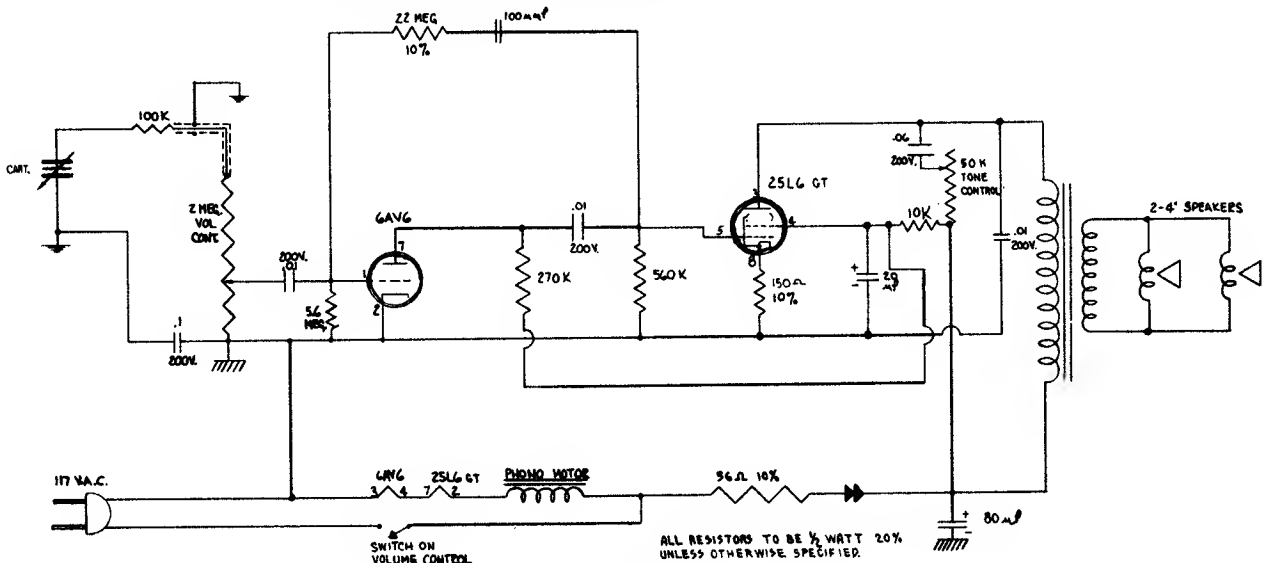



CHASSIS 7XT40    CIRCUIT #1  
 CHASSIS 7XT40    CIRCUIT #2  
 CHASSIS 7XT40Z  
 CHASSIS 7XT40Z1

## MODEL "ROYAL 500" ALL TRANSISTOR RADIO

Material on Chassis 7XT40, Circuit #1, (Black code dot), is printed on page 184, in Volume 16, 1956 RADIO Diagram Manual. Service material on these receivers using the other circuits is printed below and on pages 187 through 189.

The "Royal 500" seven transistor portable has been produced with four basic chassis. This expedient was necessary to enable us to produce sufficient quantities by using transistors from many sources. All chassis have the chassis number stamped on them as well as a color identifying code on the battery compartment just above the battery installation instruction label. They are as follows:

- Chassis 7XT40 - (Black) code dot
- Chassis 7XT40 - (Maroon) code dot
- Chassis 7XT40Z - (Red) code dot
- Chassis 7XT40Z1 - (Green) code dot

The two 7XT40 chassis are very similar with the exception of the different coding on transistors. The transistors in these two chassis are manufactured by Sylvania.

The 7XT40Z uses transistors manufactured by Raytheon Mfg. Co.

The 7XT40Z1 uses transistors manufactured by Texas Instruments Inc.

In addition to this, each receiver has its individual transistor layout label and the color of the printing on these labels as well as the chassis number on these labels conforms respectively to the color dot and chassis number.

You will note that the initial 7XT40 circuit diagram illustrates an external earphone connection at the output of the driver transistor. This is also true of all the other chassis manufactured up to serial no. 33240. These chassis use an earphone part no. 39-20 which has an impedance of 2,000 ohms. Later on in receivers manufactured after serial number 33240, the earphone jack will be removed from the driver circuit and placed in the speaker voice coil circuit. A new earphone with an impedance of 15 ohms, part no. 39-22, will be required for this circuit.

### ENGINEERING MODIFICATIONS

Since transistor circuitry is new and improvements are continually being discovered, Circuit 1 is for the original 7XT40 Chassis. The engineering staff has found ways to improve the AGC system as well as other portions of the circuitry. Therefore, the following engineering changes are design improvements on the original 7XT40 (See Circuit 2, 7XT40).

1. Originally the bias bleeder on the first IF stage was 100K and 15 K plus a 2 K volume control from B + to ground. The AGC by-pass of 3 mfd was at the junction of the 100 K and 15 K which meant that there was 15 K in series with the AGC current. During production the amount of AGC was found to be insufficient. The bias bleeder was then changed to 100 K, 4700, 4700 and 5 K volume control. The AGC by-pass of 16 mfd was put between the two 4700 ohm resistors.
2. 4700 and 47 K in junction with C15 and C16 were 2200 and 18 K respectively. This change was made to stabilize collector current of the driver transistor and slightly increase its gain.
3. In the event you do not wish to modify the circuit as in item 1, it is suggested that when servicing sets which exhibit AGC and overload problems, the bias bleeder of the first IF stage be changed. The original circuit had a 100 K and 15 K. These values should be changed to 47 K and 4700 ohms respectively. This in effect supplies more AGC voltage to the mixer and first IF.
4. You will note that C5 and C6 in the revised 7XT40 diagram have been terminated at ground and of course then the 470 ohm resistor from the 1st IF emitter must be by-passed with C23 a .05 condenser. C7 and C8 are terminated at ground for production convenience.

The 7XT40Z has not had any modifications up to the present time.

The 7XT40Z1 -

1. The 2200 ohm bias resistor in the 121-17 second IF transistor was 4700 ohms. It has been changed to 2200 ohms to reduce tweet, by slightly lowering gain.
2. 1 K resistor in the emitter of the 121-16 mixer was 470 ohms. This change was made to reduce tweet and noise.
3. On the patent & transistor layout label for 7XT40Z1 (Green Printing) the mixer transistor was marked 121-6. This was a typographical error and it should be 121-16.

### ALIGNMENT PROCEDURE

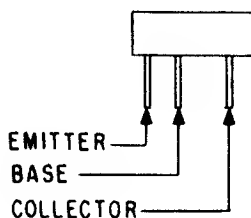

Operation	Input Signal Frequency	Connect Inner Conductor From Oscillator To	Connect Outer Shield Conductor From Oscillator To	Set Dial At	Trimmers	Purpose
1	455 KC	ONE TURN LOOSELY COUPLED TO WAVEMAGNET	Chassis	600 KC	Adj. T1, T2, T3 for max. output.	For I.F. Alignment
2	1620 KC		—	Gang wide open	C1C	Set oscillator to dial scale
3	1260 KC		—	1260 KC	C1A	Align loop antenna
4	535 KC		—	Gang closed	Adjust slug in T6	Set oscillator to dial scale
5	REPEAT STEPS 2, 3 AND 4					

ZENITH RADIO Model "Royal 500" Transistor Radio, Continued

For schematic diagram of 7XT40, Circuit #1, (Black code dot), see page 184 of Supreme Publications Volume 16, "Most-Often-Needed 1956 Radio Diagrams."

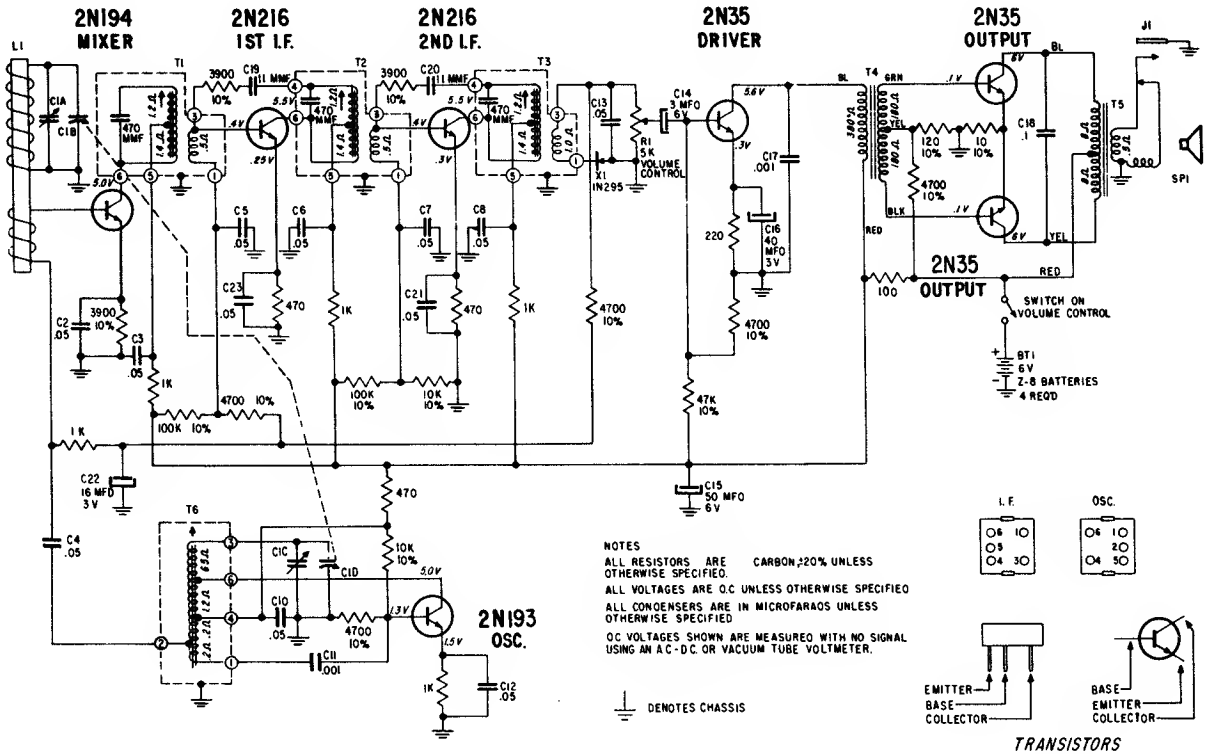

SCHMATIC DIAGRAM FOR 7XT40 CIRCUIT #2

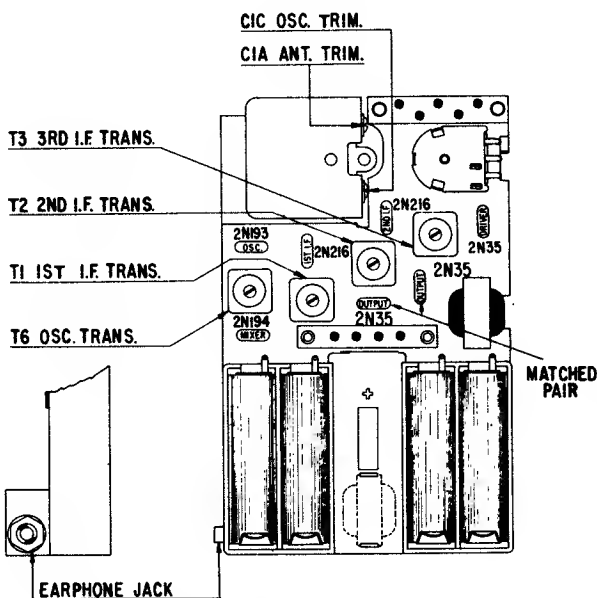

TRANSISTOR & TRIMMER LAYOUT FOR 7XT40 CIRCUIT #2

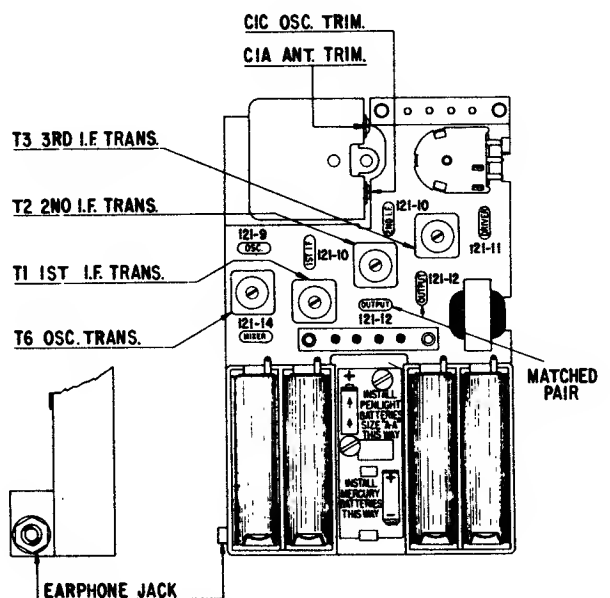

TRANSISTOR & TRIMMER LAYOUT FOR 7XT40Z

ZENITH RADIO Model "Royal 500" All Transistor Radio, Continued

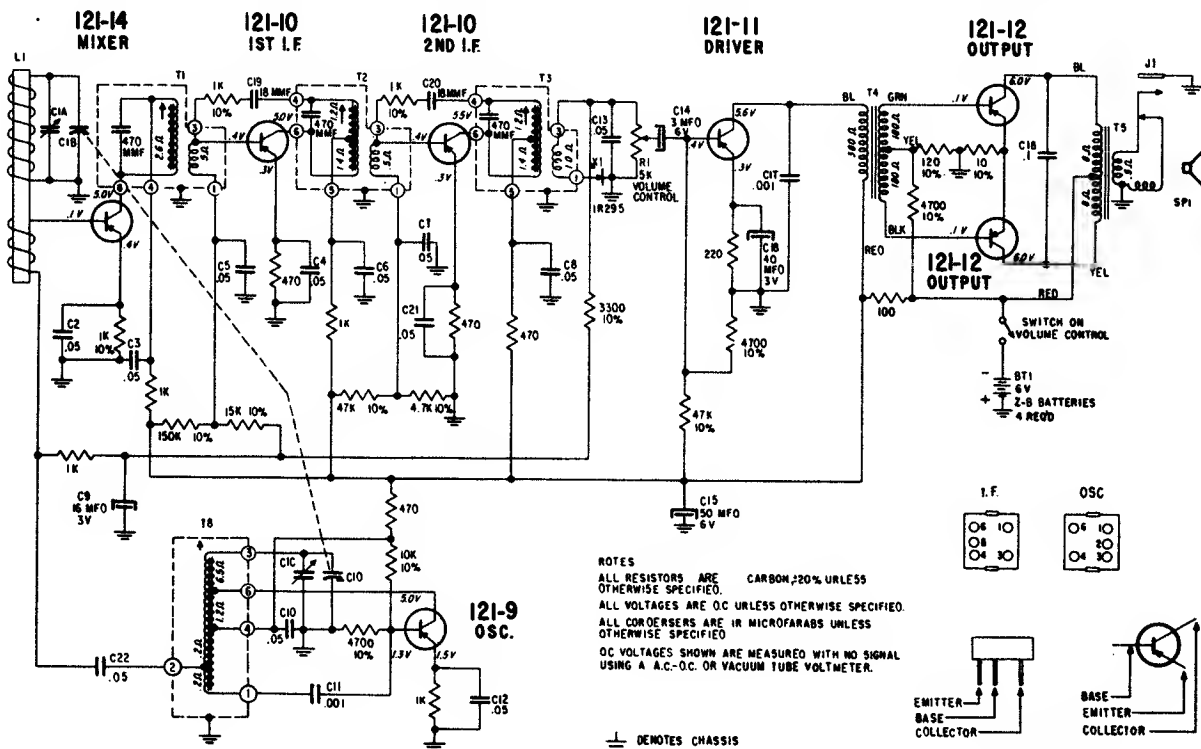

**SCHEMATIC DIAGRAM FOR 7XT40Z**

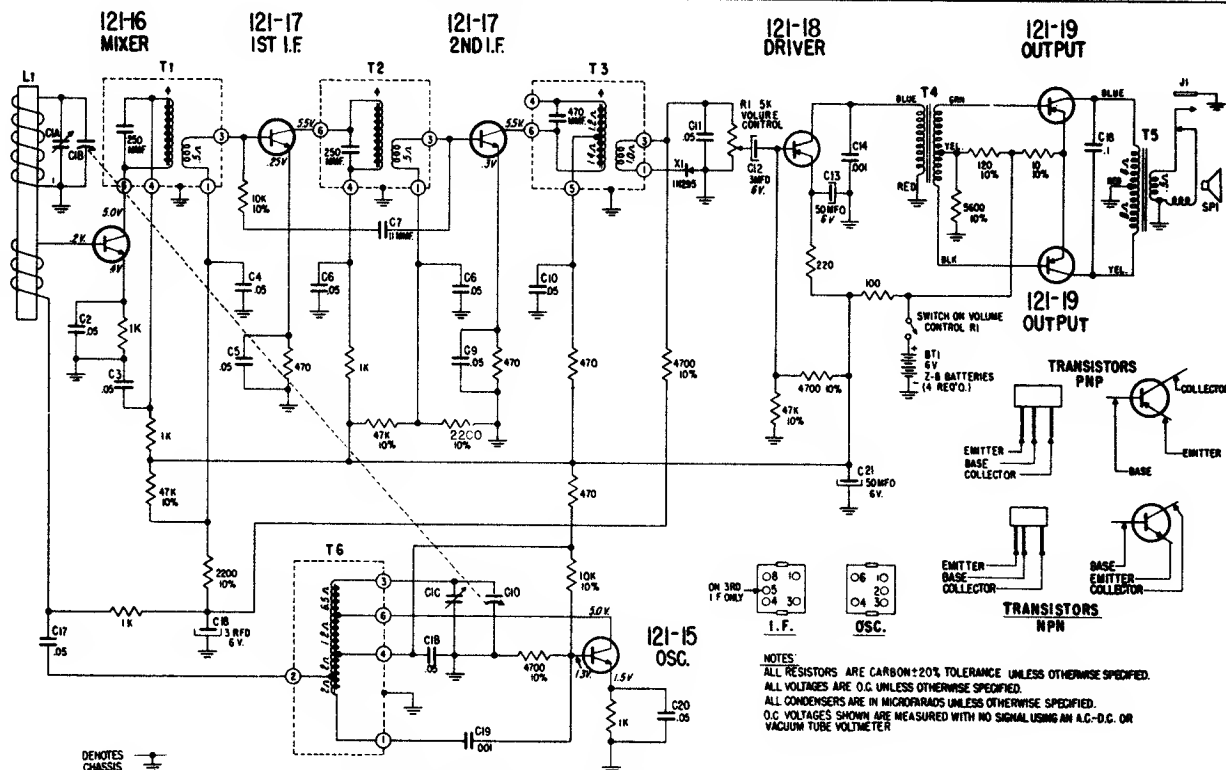

**SCHEMATIC DIAGRAM FOR 7XT40Z1**

ZENITH RADIO Additional Variations on Model "Royal 500" Radio, Continued

# SCHEMATIC DIAGRAM FOR 7ZT40

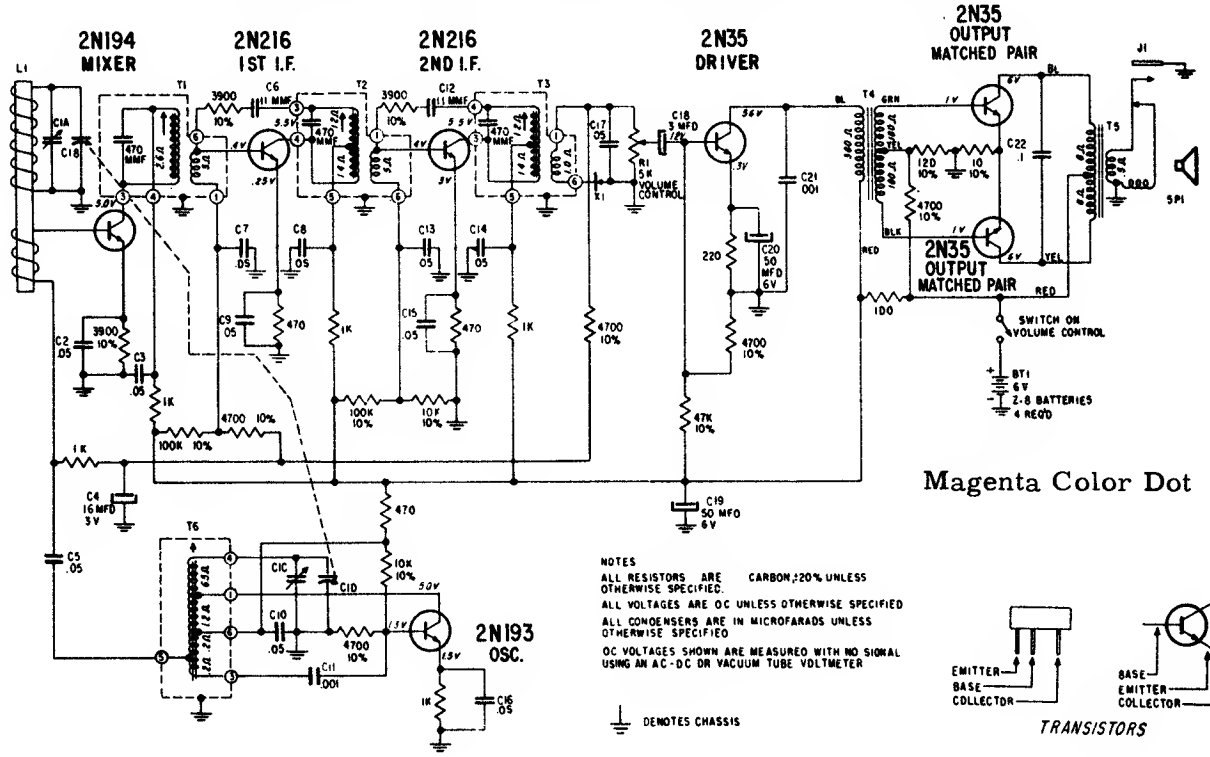

Magenta Color Dot

# SCHEMATIC DIAGRAM FOR 7ZT40Z1

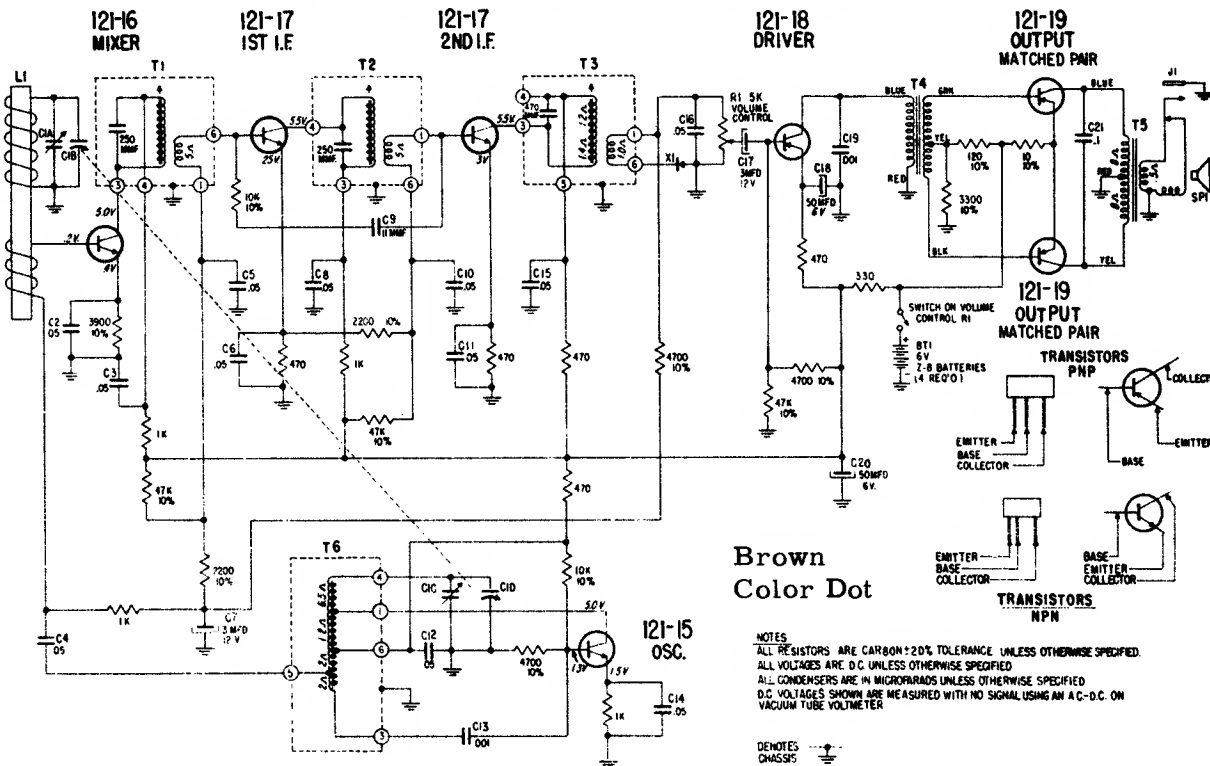

Brown Color Dot

ZENITH RADIO CORPORATION

MODEL "ROYAL 800" RADIO CHASSIS 7ZT41

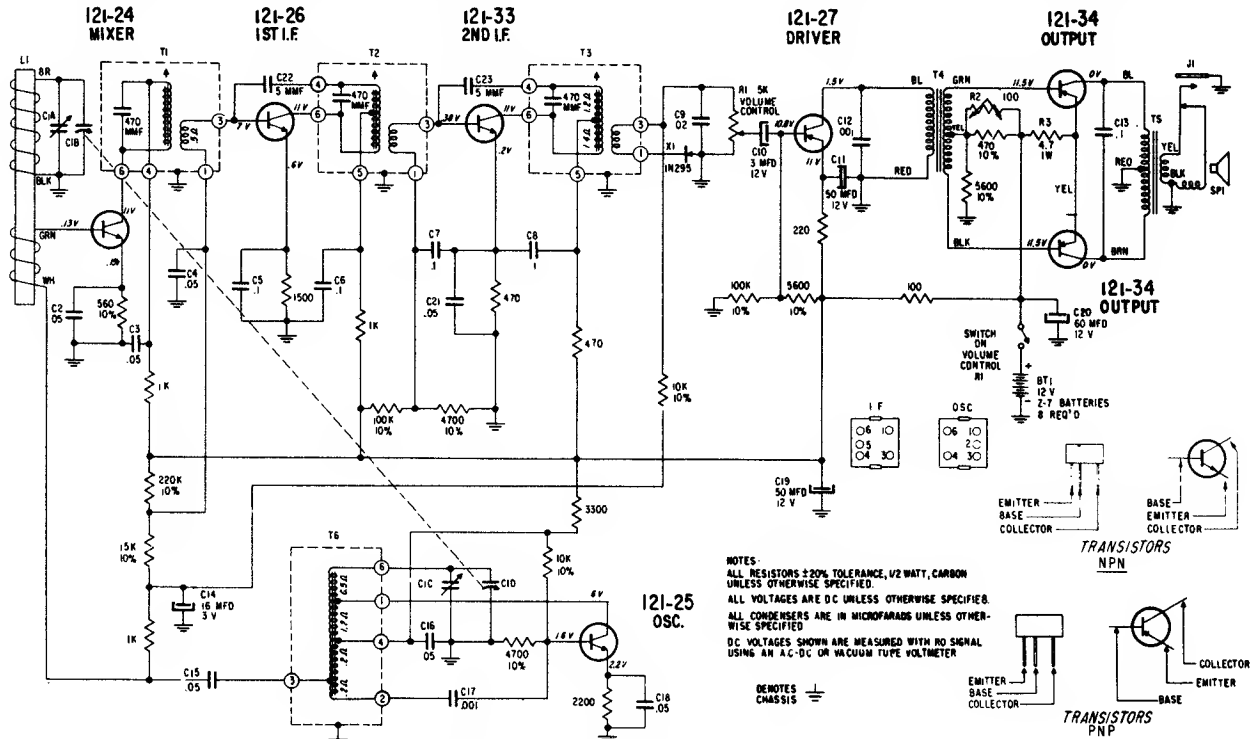

ALIGNMENT PROCEDURE

Operation	Input Signal Frequency	Connect Inner Conductor From Generator To	Connect Outer Shield Conductor From Generator To	Set Dial At	Trimmers	Purpose
1	455 KC	ONE TURN LOOSELY COUPLED TO WAVEMAGNET	Chassis	600 KC	Adjust T1, T2, T3 for maximum output	For I.F. Alignment
2	1620 KC		—	Gang wide open	C1C	Set oscillator to dial scale
3	1420 KC		—	1420 KC	C1A	Align loop antenna
4	535 KC		—	Gang closed	Adjust slug in T6	Set oscillator to dial scale
5	REPEAT STEPS 2, 3 AND 4.					

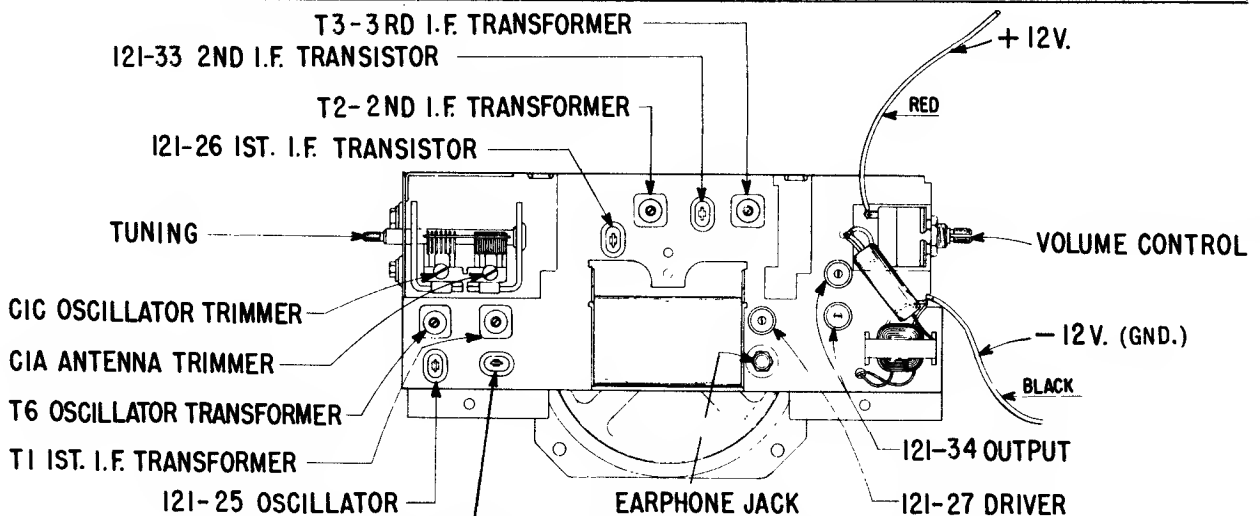

# INDEX

Under each manufacturer's name, at left there are listed that make chassis and models in numerical order. The corresponding page number at right of each listing refers to the first page of the section dealing with such material.

<u>Admiral Corp.</u>	<u>Arvin (Cont.)</u>	<u>Delco, see</u>	<u>Emerson, Cont.</u>	<u>Montgomery-</u>
3K1 3	9562 14	United Motors	120335B 30	Ward
4E2 4	1.40300 11		120336B 32	GEN-1090A 47
4E21 4	1.40400 11	<u>DeSoto</u>	120340B 33	GSL-1575A 48
4F22 4	1.40600 12	846 72	<u>Firestone Tire</u>	GSL-1575B 48
4F24 4	1.40800 13	919 75	4-B-82 34	GSL-1576A 48
4F26 4	1.40900 14		4-B-83 34	GSL-1576B 48
4F28 4	1.41200 13		4-C-29 35	<u>Motorola, Inc.</u>
4H2 4		<u>DeWald Radio</u>		BR2RC 78
4H22 4	<u>Buick</u>	K-544A 21	<u>Ford (Auto)</u>	6MR 66
4H24 4	BKA 6A 63	K-701B 22	FEG-18806G 70	BKA 6A 63
4H26 4		K-702B 22	FEG-18806H 68	BKA 6T 64
4H28 4	<u>CBS-Columbia</u>			7MR 66
4L2 6	C220 15	<u>Dodge</u>	<u>Gamble-Skogmo</u>	27F1 59
4L21 6	C230 15	624 67	RA48-8342A 36	27F2 59
4L24 6	C231 15	845 72		37F1 59
4L25 6	C232 15	918 75	<u>General-Elect.</u>	37F2 59
4L26 6	C240 15		455S 41	56T1A 77
4L28 6	616 15	<u>Du Mont Labs.</u>	456S 41	56T1B 77
4M2 6	636 15	RA-354 23	457S 41	57A1 50
4M22 6	656 15	RA-378 26	P715 37	57A2 50
4M23 6		RA-379 26	P716 37	57A3 50
4M25 6	<u>Chevrolet</u>	1110 24	P720 37	57CC1 57
4M28 6	987573 155	1120 24	P721 37	57CC2 57
4N2 7	987575 157	1130 24	850 38	57CD1, -A 54
5M3A 8	987693 159	1140 24	870 39	57CD2, -A 54
5M56, -B 8		1150 24	871 39	57CD3, -A 54
5M57, -B 8	<u>Crosley Corp.</u>		875 41	57CD4, -A 54
7L1 9	41T 18	<u>Emerson Radio</u>	876 41	57CE 56
7L12 9	T-41BK 18	844 27	877 41	57CE1 56
7L14 9	T-41GN 18	847 27	930 41	57CE2 56
7L16 9	T-41GY 18	849 28	935 41	57CF1 56
7L18 9	T-41IY 18	851B 30	936 41	57CF2 56
HT2236 3	T-41RD 18	852B 30	940 42	57CS1, -A 50
HT2237 3	P-50BG 17	853B 30	941 42	57CS2, -A 50
HS3376 7	P-50BK 17	855 29	942 42	57CS3, -A 50
HS3377 7	P-50WE 17	858B 32	955 40	57CS4, -A 50
	60T 20	860B 33	956 40	57H1, -A 51
<u>American Mot.</u>	P-60BE 17	861B 33	<u>Granco Prod.</u>	57H2, -A 51
8990377 66	P-60GY 17	866B 33	750 43	57H3, -A 51
8990455 66	P-60PK 17	120309 27		57H4, -A 51
	P-60RD 17	120314 29	<u>Hallcrafters</u>	57HFP1 61
<u>Arvin Indust.</u>	T-60CL 20	120324 28	TR-88 44	57HFP2 61
2563 11	T-60GN 20	120327B 30		57R1 50
2564 11	T-60GY 20	120328 27	<u>Magnavox</u>	57R2 50
3561 12	T-60IY 20	120334B 30	AM2 46	57R3 50
5561 13	T-60RD 20		CR-734 147	57R4 50
8565 13	5060P 17			57RF1 60

(Index continued on page 192)

VOLUME R-17, MOST-OFTEN-NEEDED 1957 RADIO SERVICING INFORMATION

INDEX Continued

<b>Motorola, Cont.</b>	<b>Packard-Bell</b>	<b>RCA, Continued</b>	<b>Sylvania Elec.</b>	<b>Westinghouse+</b>
57RF2 60	4RB1 91	8C7 117	1-602-9 148	V-2239-2 163
57W1,-B 52	5R1 92	8C8 117	1-607-5 149	V-2259-2 164
57W1MC 52		8-EY-4DJ 114	1-607-6 149	V-2268-1 to
57X1 52		8-EY-4FK 114	1-612-1 151	V-2268-4 165
57X2 52		8X8 118	1-612-2 152	V-2271-1 166
66T1 58	<b>Philco Corp.</b>	RS-152C 111	1-615-1 150	V-2278-1 167
67C1 55	T-7 104	RS-152D 112	1-615-2 150	V-2278-2 168
67C2 55	E-670 95	RS-153 112	1202 150	V-2278-3 171
67HFK1 62	E-672 95	RS-157A 112	2101 149	V-2295-1 170
67HFK2 62	E-675 95	RS-158 113	2202 149	
67HFK3 62	E-676 95	RS-159 114	2301 150	<b>Zenith Radio</b>
67HFK4 62	E-740 96	RS-160 114	2302 148	4Z40 172
67HFP1 62	E-742 96	RP-205 119	3202 152	4Z41 172
67HFT1 62	E-748 98	RC-1156A 116	3303 152	5Y40 173
67X1 53	E-810 96	RC-1161 107	3304 152	5Z01 174
67X2 53	E-812 96	RC-1161A 107	3401 151	5Z02 174
75MF 68	E-814 96	RC-1162 110		5Z03 175
76T1 49	E-816 96	RC-1163 108	<b>Trav-ler</b>	5Z04 176
76T2 49	E-818 98	RC-1166 117	55C42 153	5Z05 177
78MF 70	E-976 100	RC-1167 118	55C46 153	5Z06 178
HS-507 49	E-1351 102	RC-1169 115	65C45 154	5Z07 179
HS-521 50	E-1353 102	RC-1169A 115		5Z08 180
HS-522 50	E-1355 102		<b>United Motors</b>	5Z10 181
HS-523 51	E-1360 102	<b>Raytheon</b>	987573 155	5Z21 182
HS-524 52	E-1363 103	6RT1 141	987575 157	6Z03 183
HS-525 52	E-1370 96	7RT4 142	987693 159	6Z05 184
HS-526 53	E-1763 103	T-150-1 141	988623 161	7XT40,#2 186
HS-527 50	E-1765 103	T-150-2 141		7XT40Z 186
HS-528 54	E-1766 106	T-150-3 141	<b>Westinghouse</b>	7XT40Z1 186
HS-529 55	C-5690(HR) 93	T-150-4 141	H-499T5B 164	7ZT41 190
HS-530 56	M-5741 94	T-150-5 141	H-500T5B 164	ZP7L 185
HS-531 57		T-150-5 141	H-501T5B 164	HFZ18R 182
HS-540 59		T-2500 142	H-503T5B 164	HFZ19E 182
HS-541 59	<b>Plymouth</b>		H-551T5B 164	Z400 172
HS-542 60	849 72	<b>Sears, Roebuck</b>	H-557P4 166	Z402 172
HS-543 61		7006 11	H-558P4 166	Z404 172
HS-544 62	<b>Pontiac</b>	7007 11	H-559P4 166	Y506L 173
HS-553 77	988623 161	7013 12	H-562P4 165	Z508B 177
HS-554 77		7014 12	H-563P4,A 165	Z508L,V 177
HS-556 58		7018 143	H-564P4,A 165	Z510G,R,W 181
HS-565 51	<b>RCA Victor</b>	7020 144	H-565P4 165	Z511R 174
HS-566 50	7BX6 107	7021 144	H-574T4 163	Z512F,G 174
HS-567 54	7BX7 107	7022 144	H-575T4 163	Z512Y 174
624 67	7BX8 110	7025 146	H-576T4 163	Z515,W,Y 178
845 72	7BX9H 108	7026 146	H-577T4 163	Z519P,R 179
846 72	7-EMP-1J 111	7027 146	H-587P7 167	Z519V,W,Y 179
849 72	7-EMP-1K 111	7222 145	H-588P7 167	Z522,G 175
918 75	7-EP-2 112	132.39900 11	H-589P7 167	Z522R,V 175
919 75	7-EP-45 112	132.40100 12	H-598P4 166	Z524W,Y 176
FEG-18806H 68	7-ES-6H 112	528.46500 143	H-599P4 166	Z550G 180
	7-ES-6J 112	528.46600 144	602P7 170	Z615F,G 184
	7-HF-5 113	528.46700 146	H-610P5 168	Z615R,W 184
<b>Olympic Radio</b>	7-HF-45 114	528.46701 146	H-611P5 168	Z624,-G 183
404 87	8BT7 115	528.48000 145	H-612P5 168	Z624W,Y 183
407 88	8BT8 115		H-617P7,A 171	500 186
446 89	8BT8 115	<b>Spartan</b>	H-618P7,A 171	800 190
447 90	8BT1OK 116	CR-734 147	H-619P7,A 171	